

TABLE "A"
DECK JOIST SPANS
(DOUGLAS FIR #2 OR BETTER)

SIZE	SPACING	SPAN
2 X 6	12" O.C.	10' - 6"
	16" O.C.	9' - 0"
	24" O.C.	7' - 6"
2 X 8	12" O.C.	14' - 0"
	16" O.C.	12' - 0"
	24" O.C.	9' - 6"
2 X 10	16" O.C.	15' - 0"
	24" O.C.	12' - 0"
2 X 12	24" O.C.	14' - 0"
4 X 6	12" O.C.	14' - 6"
	16" O.C.	13' - 6"
	24" O.C.	11' - 6"
4 X 8	24" O.C.	15' - 0"
4 X 10	32" O.C.	15' - 0"

TABLE "B"
HEADER SIZING & SPANS
(DOUGLAS FIR #2 OR BETTER)

JOIST SPAN	HEADER	
	SIZE	SPAN
UPTO 8'-0"	4 X 8	8'-0"
	4 X 10	10'-0"
	4 X 12	11'-6"
	6 X 12	14'-0"
8'-1" - 10'-0"	4 X 8	7'-6"
	4 X 10	9'-6"
	4 X 12	11'-0"
	6 X 12	13'-0"
10'-1" - 12'-0"	4 X 8	7'-0"
	4 X 10	9'-0"
	4 X 12	10'-0"
	6 X 12	12'-0"
12'-1" - 15'-0"	4 X 8	6'-6"
	4 X 10	8'-0"
	4 X 12	9'-6"
	6 X 12	11'-0"

TABLE "C"
LEDGER BOLT SPACING
(3/8 DIA. X 6" LAG BOLTS - SEE NOTE 1)

DECK JOIST SPAN	SPACING
8'-0" OR LESS	8" O.C.
8'-1" TO 10'-0"	7" O.C.
10'-1" TO 12'-0"	6" O.C.
12'-1" TO 14'-0"	5" O.C.
14'-1" TO 15'-0"	4" O.C.

NOTES:

1. LEDGER BOLTS SHALL BE 3/8" DIA. X 6" LONG WITH 1/4" DIA. PRE DRILLED HOLES. BOLTS ARE TO BE PLACED STAGGERED.
2. ALL METAL HARDWARE & SCREWS TO BE GALVANIZED OR OF OTHERWISE APPROVED CORROSION RESISTANCE
3. MAXIMUM 5' JOIST SPAN IF 2ND FLOOR IS CANTILEVERED AT LEDGER.
4. SHEAR WALLS MAY NOT BE MODIFIED UNLESS STRUCTURAL CALCULATIONS ARE SUBMITTED AND APPROVED BY THE BUILDING DEPARTMENT

DISCLAIMER:

ALTERNATE DECK DESIGNS MAY BE POSSIBLE WHEN PROVIDED WITH AN ENGINEERED ANALYSIS. USE OF THIS CONVENTIONAL STANDARD DESIGN IS AT THE USER'S RISK AND CARRIES NO IMPLIED OR INFERRED GUARANTEE AGAINST FAILURE OR DEFECTS.

**CITY OF AGOURA HILLS
BUILDING DEPT.**

Balcony/Deck Standard
Page 1 of 4



KNEE BRACE DETAIL (A)

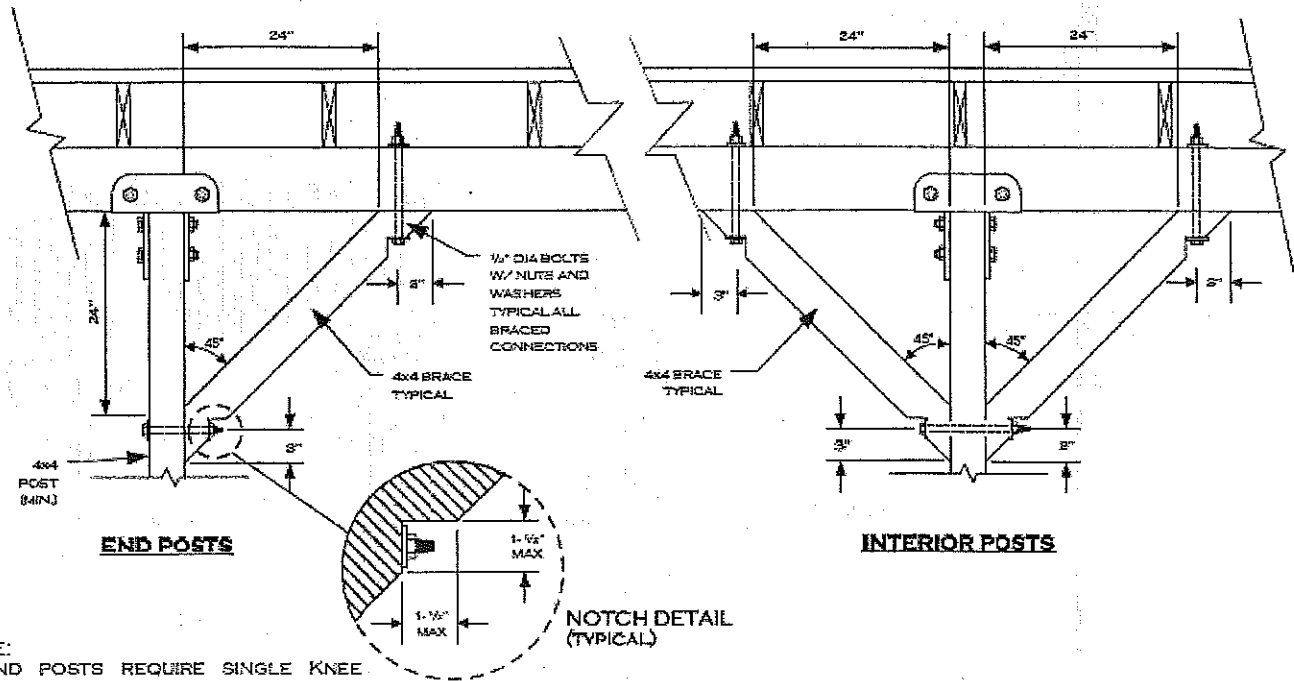

NOTE:
 1. END POSTS REQUIRE SINGLE KNEE BRACE. ALL INTERIOR POSTS TO HAVE DOUBLE BRACES.

LEDGER DETAIL (B)

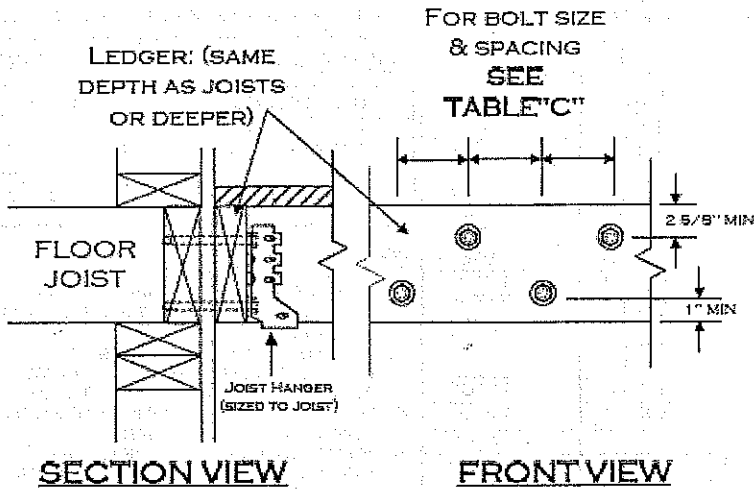

FOOTING DETAIL (C)

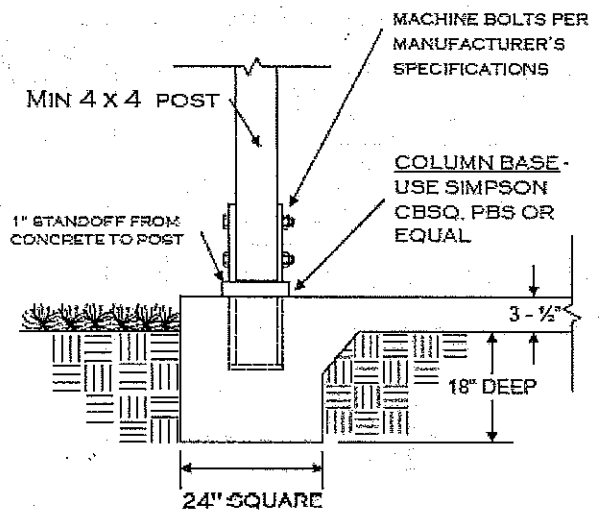

NOTE: THIS DECK CONNECTION DETAIL IS BASED ON THE ASSUMPTION THAT A MINIMUM 1-1/2" THICK WOOD MEMBER IS ADEQUATELY INSTALLED AT ALL EDGES OF THE 2ND FLOOR DIAPHRAGM. IF ANY OTHER MATERIAL IS USED, SUCH AS TJI JOISTS, A SPECIAL ENGINEERED DESIGN WILL BE REQUIRED. IT IS THE OWNER'S RESPONSIBILITY TO VERIFY THE PRESENCE OF THE APPROPRIATE RIM JOIST.

CITY OF AGOURA HILLS
BUILDING DEPT.
 Balcony/Deck Standard
 Page 2 of 4



RAILING, POST, & BEAM DETAIL (D)

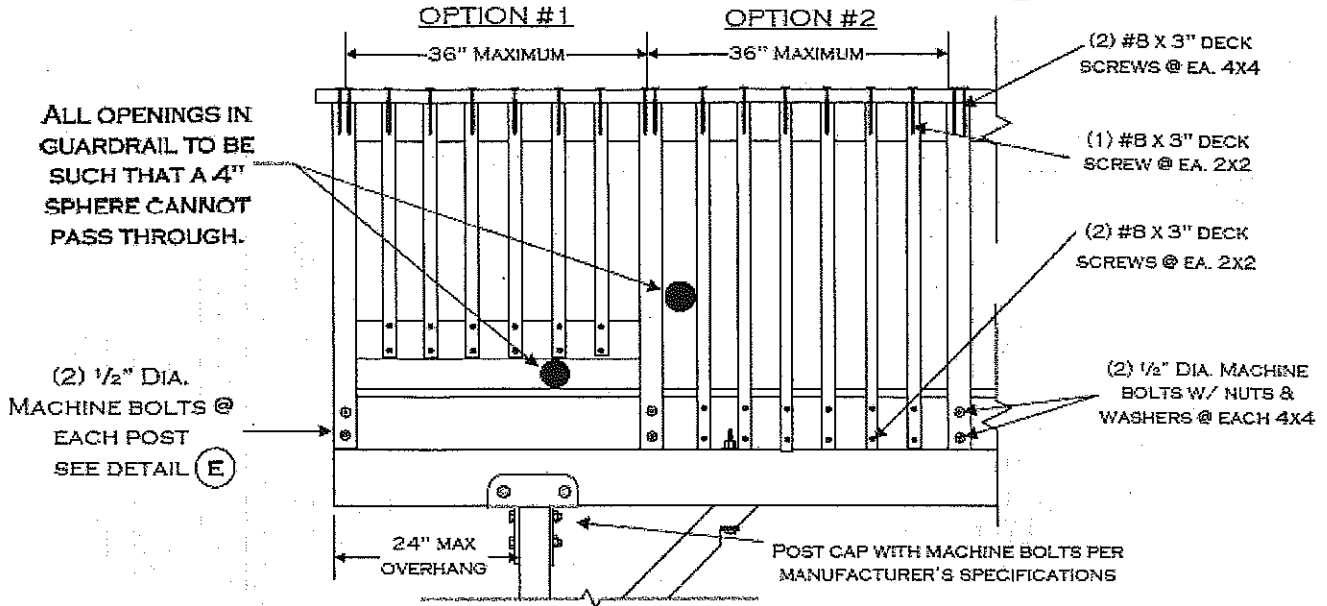

RAILING SECTION VIEWS (E)

GUARDRAIL PERPENDICULAR TO JOISTS

GUARDRAIL PARALLEL TO JOISTS

NOTE: GUARDRAILS/HANDRAILS LOCATED MORE THAN 30" MEASURED VERTICALLY TO THE ADJACENT GRADE ON THE OPEN SIDE SHALL HAVE A HEIGHT OF 42" MINIMUM.

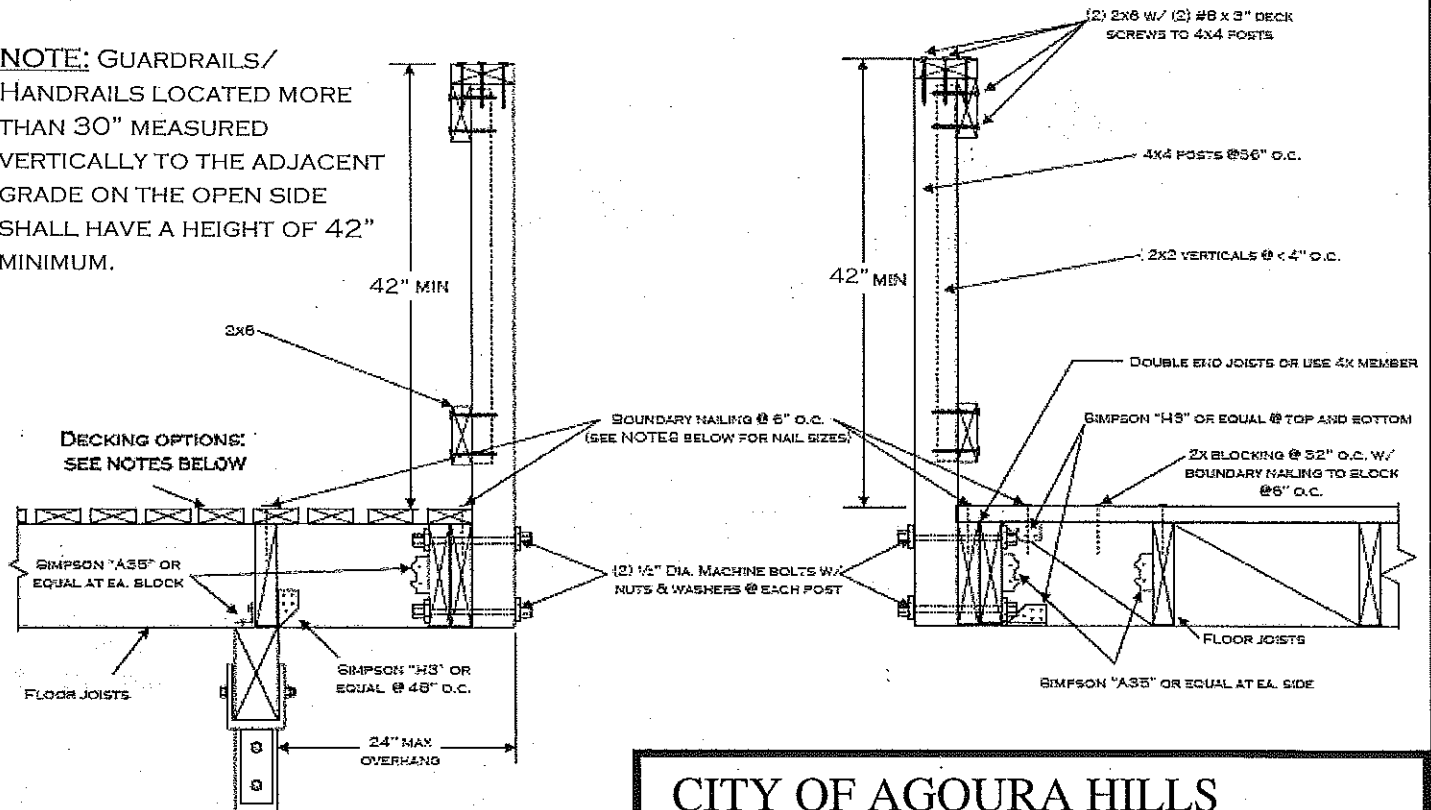

NOTE-DECKING OPTIONS ARE AS FOLLOWS:

- 5/8" TONGUE AND GROOVE JOINTED PLYWOOD SECURED WITH 8d NAILS. ALL EDGE NAILING AT 6" O.C. MUST BE COVERED WITH AN APPROVED WEATHER RESISTIVE MATERIAL WALKING SURFACE, AND SLOPED FOR DRAINAGE.
- 2X6" DECKING SECURED W/ (2) 16d NAILS @ EA. JOIST.

CITY OF AGOURA HILLS
BUILDING DEPT.

Balcony/Deck Standard

Page 3 of 4



OPTIONAL EXTERIOR STAIRWAY

NOTES:

1. THE LARGEST TREAD RUN SHALL NOT EXCEED THE SMALLEST BY MORE THAN 3/8".
2. STAIRWAY WIDTH 36" MIN - 48" MAX.
3. TREADS MUST HAVE APPROVED SLIP RESISTANT SURFACE
4. ALTERNATE STAIRWAY DESIGNS MAY BE ACCEPTABLE PENDING BUILDING DEPARTMENT APPROVAL

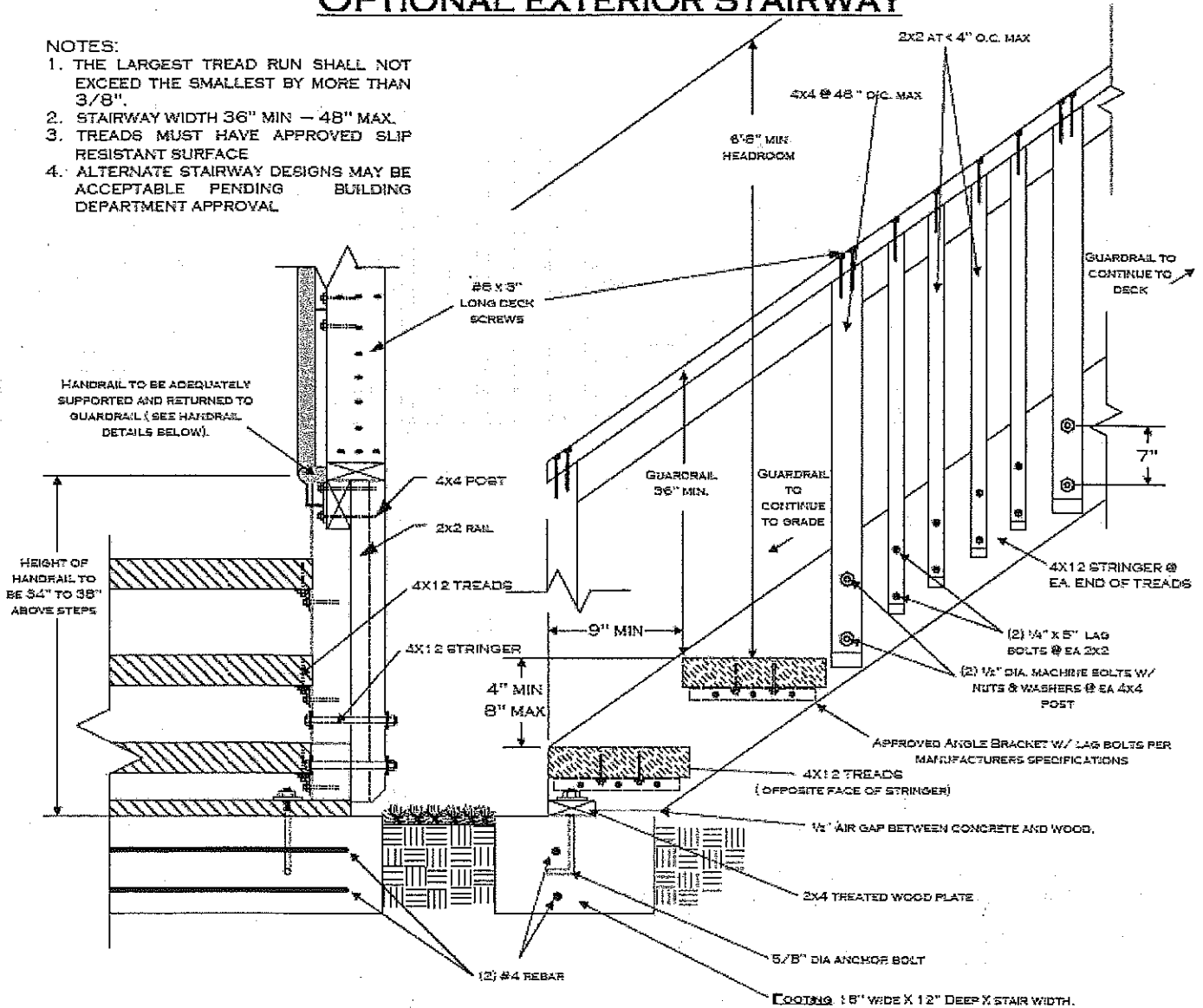

FRONT VIEW

SIDE VIEW

HANDRAIL DETAILS

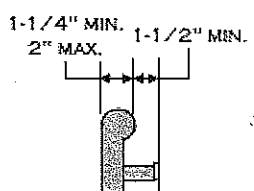
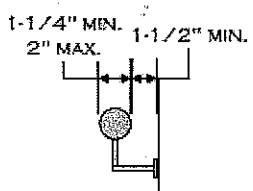
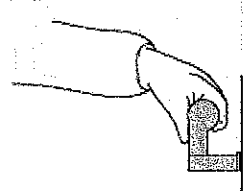

NOTE: OTHER SHAPES MAY BE ACCEPTABLE IF THEY PROVIDE AN EQUIVALENT GRIPPING SURFACE.

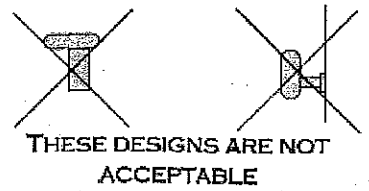

CITY OF AGOURA HILLS
BUILDING DEPT.
Balcony/Deck Standard
 Page 4 of 4



AGOURA HILLS