



STAFF REPORT TO CITY COUNCIL

DATE: MARCH 22, 2017

TO: HONORABLE MAYOR AND MEMBERS OF THE CITY COUNCIL

FROM: GREG RAMIREZ, CITY MANAGER 

BY: ZACH MILLER, ASSISTANT DIRECTOR OF COMMUNITY SERVICES 

SUBJECT: REQUEST FOR APPROVAL OF AGREEMENT OF CONTRACTOR SERVICES BETWEEN CITY OF AGOURA HILLS AND EVOLUTION AUDIO AND VIDEO FOR THE INSTALLATION OF AN AUTOMATED SHADE SYSTEM AT THE EVENT CENTER

With the opening of the new Agoura Hills Recreation and Event Center in January 2015, the City of Agoura Hills is able to offer the community a venue to host private events, meetings, and a variety of public uses throughout the year. Since opening, The Event Center has hosted over 150 private events, and over 50 City sponsored special events. Due to the design of the building, and the large amount of natural light that enters the room during daytime hours, it has been more difficult to host events during the day. Projectors are not designed to efficiently project onto screens with the amount of daylight that enters the room. This limitation has significantly impacted the ability to attract and host business rentals, as most meetings of this magnitude require audio/visual capabilities beyond the current capacities. Based on the feedback from a variety of businesses that have toured and inquired about the facility, the addition of an automated shade system would significantly increase the number of rentals, and in turn, increase the amount of revenue the room was able to generate during regular business/daytime hours. This upgrade would also allow City staff to host larger meetings, staff trainings, and special events, such as State of the City, that currently require the use of portable screens rented from outside contractors.

Staff reached out to a variety of companies that claimed to have the ability to integrate an automated shade system with the existing equipment and programming that currently exists in The Event Center. Staff has determined that Crestron shades would be the only viable solution in order for the entire audio/visual system to work seamlessly together. Evolution Audio and Visual, a local Agoura Hills business, was the only company that agreed to meet with staff to visually inspect and provide a quote for the installation of the Crestron equipment.

The total cost of this project is \$59,060.40, and has been budgeted to be completed in Fiscal Year 16/17. The Crestron equipment required for the installation of this project is \$46,610.40 (including tax and shipping costs), and was negotiated to the lowest price, regardless of the installer. Evolution Audio and Visual has provided a quote of \$12,450

in order to successfully provide any remaining installation materials (cables, wiring, lifts, etc.), install, program, and test the system. Staff is confident that the City is receiving the best rate possible for the labor and materials required to complete the job.

The completion of this project, in a timely manner, would allow the Department of Community Services to begin actively renting The Event Center as a daytime business destination, with the full capabilities of video conferencing, AV presentations, and networking groups to be able to rent the facility throughout the day. The increased revenue from these rentals would certainly offset the project cost, over time, and be a significant upgrade and benefit to the City of Agoura Hills and the business community.

The proposed agreement has been reviewed by the City Attorney and approved as to form.

RECOMMENDATION

Staff respectfully recommends the City Council:

1. Approve the Agreement for Contractor Services with Evolution Audio and Video.
2. Authorize the Mayor to sign the agreement on behalf of the City Council.

Attachment: Agreement for Contractor Services between the City of Agoura Hills and Evolution Audio and Video

AGREEMENT ROUTING SLIP FOR

[Insert Name of Contractor Here]

Evolution Audio & Video

Contractor Name (Over \$25K with Prevailing Wage)

Attached, Please Find (Check One of the Following Boxes Below):

Note: Standard Template – NO CHANGES
Use Standard Template / Routing Slip

Outside Agency Agreement (i.e., County, State, etc.)
Complete Sections 1 and 2



Standard Template – WITH CHANGES
Complete Sections 1 and 2

Special Agreement (i.e., Customized)
Complete Sections 1 and 2

Section 1 – OBTAIN APPROVAL(S) FOR CHANGES TO TEMPLATE: The Department Head will authorize any amendment(s). Check with the Risk Manager for insurance and/or template amendments **BEFORE** contacting the City Attorney. If authorized to contact the City Attorney, attach the email response (approval) to this slip. **Submit the draft agreement to the City Clerk for review, prior to forwarding to Contractor for signatures.**

AD (Dept. Head Initials/Date)
Authorization to Amend Agreement

_____ (Risk Manager Initials/Date)
Approval to Forward to City Attorney

_____ (Risk Manager Initials/Date)
Insurance Amended (See Notes Below)

_____ Staff Initials (From No. 1 Below)
City Attorney Email Approval Attached

_____ (Risk Manager Initials/Date)
Template Amended (See Notes Below)

_____ (City Clerk Initials/Date)
Template/Format Review

Section 2 – FINAL DISTRIBUTION OF AGREEMENT:

Attach this routing slip to front of agreement and route to staff in numerical order (1-3) to the right. City Clerk will review format and return to Department for Contractor signatures. When signed, submit the final agreement, including the appropriate certificate of insurance and endorsement, with this completed routing slip, to the City Clerk who will review and forward to the Risk Manager for review and approval. Agreements without the appropriate insurance attached will be returned to the department. Once approved, the City Clerk will execute the agreement and provide a copy to the Contractor and the staff person (in Item No. 1).

1. Zach Moore 3/15/17
Prepared by (Staff Name/Date)

2. Amy R 3.15.17
Department Head - Date
(Authorization to forward to Risk Mgr/Clerk)

3. _____
City Clerk – Sign/Date Final Review
3/16/17 Initial/Date – Format Review

4. [Signature] 3/26/17
Risk Manager – Date
(Insurance Review/Approval)

Notes:

Insurance limits changed to match policy. No other changes to template.

** Endorsement outstanding - JT following up need before they begin work h7+*

**AGREEMENT FOR CONTRACTOR SERVICES
WITH THE CITY OF AGOURA HILLS**

NAME OF CONTRACTOR: Evolution Audio & Video

RESPONSIBLE PRINCIPAL OF CONTRACTOR: Attn: Jay Frank

CONTRACTOR'S ADDRESS: 5341 Derry Avenue # S
Agoura Hills, CA 91301

CITY'S ADDRESS: City of Agoura Hills
30001 Ladyface Court
Agoura Hills, CA 91301
Attn: City Manager

PREPARED BY: John Treichler

COMMENCEMENT DATE: March 22, 2017

TERMINATION DATE: June 30, 2017

CONSIDERATION: Contract Price
Not to Exceed: \$ 59,060.40

ADDITIONAL SERVICES <i>(Describe Services, Amount, and Approval):</i> _____ _____ _____ _____
--

Date: _____ Amount: \$ _____ Authorized By: _____
(Not to Exceed 10% of Contract Price) City Manager

**AGREEMENT FOR CONTRACTOR SERVICES BETWEEN
THE CITY OF AGOURA HILLS AND EVOLUTION AUDIO &
VIDEO**

THIS AGREEMENT is made and effective as of March 22, 2017, between the City of Agoura Hills, a municipal corporation ("City") and Evolution Audio & Video ("Contractor"). In consideration of the mutual covenants and conditions set forth herein, the parties agree as follows:

1. TERM

This Agreement shall commence on March 22, 2017, and shall remain and continue in effect until tasks described herein are completed, but in no event later than June 30, 2017, unless sooner terminated pursuant to the provisions of this Agreement.

2. SERVICES

Contractor shall perform the services and tasks described and set forth in Exhibit A, attached hereto and incorporated herein as though set forth in full. Contractor shall complete the tasks according to the schedule of performance which is also set forth in Exhibit A.

3. PERFORMANCE

In meeting its obligations under this Agreement, Contractor shall at all times faithfully and competently perform all tasks described herein in a manner satisfactory to CITY and consistent with that level of care and skill ordinarily exercised by members of the profession currently practicing in the same locality under similar conditions.

4. PREVAILING WAGES

A. Prevailing wages are required on all CITY agreements involving construction, design, and preconstruction phases of construction (including, but not limited to, inspection and land surveying work), and maintenance (except for janitorial or security guards) for work on CITY property.

B. Pursuant to the provisions of Section 1773 of the Labor Code of the State of California, the City Council has obtained the general prevailing rate of per diem wages and the general rate for holiday and overtime work in this locality for each craft, classification, or type of workman needed to execute by this Contractor from the Director of the Department of Industrial Relations. Copies may be obtained from the California Department of Industrial Relations Internet website at <http://www.dir.ca.gov>. Consultant shall provide a copy of prevailing wage rates to any staff or sub-contractor hired, and shall pay the adopted prevailing wage rates as a minimum. Contractor shall comply with the provisions of Sections 1773.8, 1775, 1776, 1777.5, 1777.6, and 1813 of the Labor Code. Pursuant to the provisions of 1775 of the Labor Code, Contractor shall forfeit to the City, as a penalty, the sum of \$50.00 for each calendar day, or portion thereof, for each laborer, worker, or mechanic employed, paid less than the stipulated prevailing rates for any work

done under this contract, by him or by any sub-contractor under him, in violation of the provisions of the Agreement.

5. PAYMENT

A. The City agrees to pay Contractor monthly, in accordance with the payment rates and terms and the schedule of payment as set forth in Exhibit B, Payment Rates and Schedule, attached hereto and incorporated herein by this reference as though set forth in full, based upon actual time spent on the above tasks. Any terms in Exhibit B other than the payment rates and schedule of payment are null and void. This amount shall not exceed Fifty-Nine Thousand Sixty Dollars and Forty Cents (\$59,060.40) ("Contract Price") for the initial Term of the Agreement unless additional payment is approved as provided in this Agreement.

The City Manager may approve additional work up to ten percent (10%) of the amount of the Agreement. Any additional work in excess of this amount shall be approved by the City Council.

B. Contractor shall not be compensated for any services rendered in connection with its performance of this Agreement which are in addition to those set forth herein, unless such additional services are authorized in advance and in writing by the City Manager. Contractor shall be compensated for any additional services in the amounts and in the manner as agreed to by the City Council and Contractor at the time City's written authorization is given to Contractor for the performance of said services.

C. Contractor shall submit invoices monthly for actual services performed. Invoices shall be submitted between the first and fifteenth business day of each month, for services provided in the previous month. Payment shall be made within thirty (30) days of receipt of each invoice as to all non-disputed fees. If the City disputes any of Contractor's fees, it shall give written notice to Contractor within thirty (30) days of receipt of an invoice of any disputed fees set forth on the invoice. For all reimbursements authorized by this Agreement, Contractor shall provide receipts on all reimbursable expenses in excess of Fifty Dollars (\$50) in such form as approved by the Director of Finance.

6. SUSPENSION OR TERMINATION OF AGREEMENT WITHOUT CAUSE

A. The City may at any time, for any reason, with or without cause, suspend or terminate this Agreement, or any portion hereof, by serving upon the Contractor at least ten (10) days prior written notice. Upon receipt of said notice, the Contractor shall immediately cease all work under this Agreement, unless the notice provides otherwise. If the City suspends or terminates a portion of this Agreement, such suspension or termination shall not make void or invalidate the remainder of this Agreement.

B. In the event this Agreement is terminated pursuant to this Section, the City shall pay to Contractor the actual value of the work performed up to the time of termination, provided that the work performed is of value to the City. Upon termination of

the Agreement pursuant to this Section, the Contractor will submit an invoice to the City pursuant to Section entitled "**PAYMENT**" herein.

7. DEFAULT OF CONTRACTOR

A. The Contractor's failure to comply with the provisions of this Agreement shall constitute a default. In the event that Contractor is in default for cause under the terms of this Agreement, City shall have no obligation or duty to continue compensating Contractor for any work performed after the date of default and can terminate this Agreement immediately by written notice to the Contractor. If such failure by the Contractor to make progress in the performance of work hereunder arises out of causes beyond the Contractor's control, and without fault or negligence of the Contractor, it shall not be considered a default.

B. If the City Manager or his delegate determines that the Contractor is in default in the performance of any of the terms or conditions of this Agreement, it shall serve the Contractor with written notice of the default. The Contractor shall have ten (10) days after service upon it of said notice in which to cure the default by rendering a satisfactory performance. In the event that the Contractor fails to cure its default within such period of time, the City shall have the right, notwithstanding any other provision of this Agreement, to terminate this Agreement without further notice and without prejudice to any other remedy to which it may be entitled at law, in equity or under this Agreement."

8. OWNERSHIP OF DOCUMENTS

A. Contractor shall maintain complete and accurate records with respect to sales, costs, expenses, receipts and other such information required by City that relate to the performance of services under this Agreement. Contractor shall maintain adequate records of services provided in sufficient detail to permit an evaluation of services. All such records shall be maintained in accordance with generally accepted accounting principles and shall be clearly identified and readily accessible. Contractor shall provide free access to the representatives of City or its designees at reasonable times to such books and records, shall give City the right to examine and audit said books and records, shall permit City to make transcripts there from as necessary, and shall allow inspection of all work, data, documents, proceedings and activities related to this Agreement. Such records, together with supporting documents, shall be maintained for a period of three (3) years after receipt of final payment.

B. Upon completion of, or in the event of termination or suspension of this Agreement, all original documents, designs, drawings, maps, models, computer files containing data generated for the work, surveys, notes, and other documents prepared in the course of providing the services to be performed pursuant to this Agreement shall become the sole property of the City and may be used, reused or otherwise disposed of by the City without the permission of the Contractor. With respect to computer files containing data generated for the work, Contractor shall make available to the City, upon reasonable written request by the City, the necessary computer software and hardware for purposes of accessing, compiling, transferring and printing computer files.

9. INDEMNIFICATION

Contractor shall defend, indemnify, and hold the City, its officials, officers, employees, agents and independent Contractors serving in the role of City officials, and volunteers (collectively "Indemnitees") free and harmless from any and all claims, demands, causes of action, proceedings, costs, expenses, liabilities, losses, damages or injuries, in law or equity, to property or persons, including wrongful death (collectively "Claims"), in any manner arising out of or incident to any acts or omissions of Contractor, its officials, officers, employees, agents or sub-contractor in connection with the performance of this Agreement, including without limitation the payment of all consequential damages, attorneys' fees, and other related costs and expenses, except for such Claims arising out of the sole negligence or willful misconduct of the Indemnitees. With respect to any and all such Claims, Contractor shall defend Indemnitees at Contractor's own cost, expense, and risk and shall pay and satisfy any judgment, award, or decree that may be rendered against Indemnitees. Contractor shall reimburse Indemnitees for any and all legal expenses and costs incurred by each of them in connection therewith or in enforcing the indemnity herein provided. Contractor's obligation to indemnify shall not be restricted to insurance proceeds, if any, received by Contractor or Indemnitees. All duties of Contractor under this Section shall survive termination of this Agreement.

10. INSURANCE REQUIREMENTS

Prior to commencement of work, Contractor shall procure, provide, and maintain, at Contractor's own expense, for the duration of this Agreement, insurance against claims for injuries to persons or damages to property, which may arise from or in connection with the performance of the work hereunder by the Contractor, its agents, representatives, or employees.

A. Minimum Scope of Insurance. Coverage shall be at least as broad as:

1) Insurance Services Office Commercial General Liability form No. CG 00 01 11 85 or 88, or equivalent.

2) Insurance Services Office Business Auto Coverage form CA 00 01 06 92, or equivalent, covering Automobile Liability, code 1 (any auto). If the Contractor owns no automobiles, a non-owned auto endorsement to the General Liability policy described above is acceptable.

3) Worker's Compensation insurance as required by the State of California and Employer's Liability Insurance. If the Contractor has no employees while performing under this Agreement, worker's compensation insurance is not required, but Contractor shall execute a declaration that it has no employees.

B. Minimum Limits of Insurance. Contractor shall maintain limits no less than:

1) General Liability: \$2,000,000 per occurrence for bodily injury, personal injury and property damage, including without limitation, blanket contractual liability. If Commercial General Liability Insurance or other form with a general aggregate limit is used, either the general aggregate limit shall apply separately to this project/location or the general aggregate limit shall be twice the required occurrence limit.

2) Automobile Liability: \$500,000 per accident for bodily injury and \$100,000 property damage for all activities of the Contractor arising out of or in connection with work to be performed under this Agreement, including coverage for any owned, hired, non-owned or rental vehicles.

3) Worker's Compensation as required by the State of California; Employer's Liability: One million dollars (\$1,000,000) per accident for bodily injury or disease.

C. Deductibles and Self-Insured Retentions. Any deductibles or self-insured retentions must be declared to and approved by the City Manager. At the option of the City Manager, either the insurer shall reduce or eliminate such deductibles or self-insured retentions as respects the City, its officers, officials, employees and volunteers; or the Contractor shall procure a bond guaranteeing payment of losses and related investigations, claim administration and defense expenses.

D. Requirements Not Limiting. Requirements of specific coverage features or limits contained in this Section are not intended as a limitation on coverage, limits or other requirements, or a waiver of any coverage normally provided by any insurance. Specific reference to a given coverage feature is for purposes of clarification only as it pertains to a given issue and is not intended by any party or insured to be all inclusive, or to the exclusion of other coverage, or a waiver of any type. If the Vendor maintains higher limits than the minimums shown above, the Agency requires and shall be entitled to coverage for the higher limits maintained by the Vendor. Any available insurance proceeds in excess of the specified minimum limits of insurance and coverage shall be available to the Agency.

E. Other Insurance Provisions. The general liability and automobile liability policies are to contain, or be endorsed to contain, the following provisions:

1) The City, its officers, officials, employees and volunteers are to be covered and named as additional insureds in respect to: liability arising out of activities performed by or on behalf of the Contractor; products and completed operations of the Contractor; premises owned, occupied or used by the Contractor; or automobiles owned, leased, hired or borrowed by the Contractor. The coverage shall contain no special limitations on the scope of protection afforded to the City, its officers, officials, employees or volunteers.

2) For any claims related to this project, the Contractor's insurance coverage shall be primary insurance as respects the City, its officers, officials,

employees and volunteers. Any insurance or self-insured maintained by the City, its officers, officials, employees or volunteers shall be excess of the Contractor's insurance and shall not contribute with it.

3) Any failure to comply with reporting or other provisions of the policies including breaches of warranties shall not affect coverage provided to the City, its officers, officials, employees or volunteers.

4) The Contractor's insurance shall apply separately to each insured against whom claim is made or suit is brought, except with respect to the limits of the insurer's liability.

5) Each insurance policy required by this clause shall be endorsed to state that coverage shall not be suspended, voided, canceled by either party, reduced in coverage or in limits except after thirty (30) days' prior written notice has been given to the City. Contractor agrees to oblige its insurance agent or broker and insurers to provide City with a thirty (30) day notice of cancellation (except for nonpayment for which a ten (10) day notice is required) or nonrenewal of coverage for each required coverage.

F. Acceptability of Insurers. Insurance is to be placed with insurers with a current A.M. Best's rating of no less than A:VII, unless otherwise acceptable to the City. Self insurance shall not be considered to comply with these insurance requirements.

G. Verification of Coverage. **Contractor shall furnish the City with original endorsements, specifically naming the City of Agoura Hills, its officers, officials, employees and volunteers as additional insured, effecting coverage required by this clause..** The endorsements are to be signed by a person authorized by that insurer to bind coverage on its behalf. The endorsements are to be on forms acceptable to the City. Insurance certificates and endorsements must be received and approved by City's Risk Manager prior to commencement of performance. Current insurance certificates and endorsements shall be kept on file with the City at all times during the term of this agreement. City reserves the right to require complete, certified copies of all required insurance policies, at any time.

H. Mailing Instructions. Insurance documents shall be mailed with the signed Agreement to the attention of the staff person indicated on the cover sheet of this Agreement, to the City of Agoura Hills, 30001 Ladyface Court, Agoura Hills, CA 91301. Executed Agreement(s) cannot be released nor may any work commence on a project until the signed Agreement and appropriate insurance documents are on file with the City Clerk.

11. INDEPENDENT CONTRACTOR

A. Contractor is and shall at all times remain as to the City a wholly independent contractor. The personnel performing the services under this Agreement on behalf of Contractor shall at all times be under Contractor's exclusive direction and control. Neither City nor any of its officers, employees, agents, or volunteers shall have control over the conduct of Contractor or any of Contractor's officers, employees, or

agents except as set forth in this Agreement. Contractor shall not at any time or in any manner represent that it or any of its officers, employees or agents are in any manner officers, employees or agents of the City. Contractor shall not incur or have the power to incur any debt, obligation or liability whatever against City, or bind City in any manner.

B. No employee benefits shall be available to Contractor in connection with the performance of this Agreement. Except for the fees paid to Contractor as provided in the Agreement, City shall not pay salaries, wages, or other compensation to Contractor for performing services hereunder for City. City shall not be liable for compensation or indemnification to Contractor for injury or sickness arising out of performing services hereunder.

12. LEGAL RESPONSIBILITIES

The Contractor shall keep itself informed of all local, State and Federal ordinances, laws and regulations which in any manner affect those employed by it or in any way affect the performance of its service pursuant to this Agreement. The Contractor shall at all times observe and comply with all such ordinances, laws and regulations. The City, and its officers and employees, shall not be liable at law or in equity occasioned by failure of the Contractor to comply with this section.

13. RELEASE OF INFORMATION

A. All information gained by Contractor in performance of this Agreement shall be considered confidential and shall not be released by Contractor without City's prior written authorization. Contractor, its officers, employees, agents or sub-contractors, shall not without written authorization from the City Manager or unless requested by the City Attorney, voluntarily provide declarations, letters of support, testimony at depositions, response to interrogatories or other information concerning the work performed under this Agreement or relating to any project or property located within the City. Response to a subpoena or court order shall not be considered "voluntary" provided Contractor gives City notice of such court order or subpoena.

B. Contractor shall promptly notify City should Contractor, its officers, employees, agents or sub-contractors be served with any summons, complaint, subpoena, notice of deposition, request for documents, interrogatories, request for admissions or other discovery request, court order or subpoena from any party regarding this Agreement and the work performed there under or with respect to any project or property located within the City. City retains the right, but has no obligation, to represent Contractor and/or be present at any deposition, hearing or similar proceeding. Contractor agrees to cooperate fully with City and to provide City with the opportunity to review any response to discovery requests provided by Contractor. However, City's right to review any such response does not imply or mean the right by City to control, direct, or rewrite said response.

14. NOTICES

Any notices which either party may desire to give to the other party under this Agreement must be in writing and may be given either by: (i) personal service, (ii)

delivery by a reputable document delivery service, such as but not limited to, Federal Express, that provides a receipt showing date and time of delivery, or (iii) mailing in the United States Mail, certified mail, postage prepaid, return receipt requested, addressed to the address of the party as set forth below or at any other address as that party may later designate by Notice. Notice shall be effective upon delivery to the addresses specified below or on the third business day following deposit with the document delivery service or United States Mail as provided above.

To City: City of Agoura Hills
30001 Ladyface Court
Agoura Hills, California 91301
Attention: City Manager

To Contractor: **Evolution Audio and Video**
5341 Derry Ave. Suite #2
Agoura Hills, CA 91301
Attention: Jay Frank

15. ASSIGNMENT

The Contractor shall not assign the performance of this Agreement, nor any part thereof, nor any monies due hereunder, without prior written consent of the City. Upon termination of this Agreement, Contractor's sole compensation shall be payment for actual services performed up to, and including, the date of termination or as may be otherwise agreed to in writing between the City Council and the Contractor.

16. LICENSES

At all times during the term of this Agreement, Contractor shall have in full force and effect, all licenses required of it by law for the performance of the services described in this Agreement.

17. GOVERNING LAW

The City and Contractor understand and agree that the laws of the State of California shall govern the rights, obligations, duties and liabilities of the parties to this Agreement and also govern the interpretation of this Agreement. Any litigation concerning this Agreement shall take place in the municipal, superior, or federal district court with geographic jurisdiction over the City of Agoura Hills. In the event such litigation is filed by one party against the other to enforce its rights under this Agreement, the prevailing party, as determined by the Court's judgment, shall be entitled to reasonable attorney fees and litigation expenses for the relief granted.

18. PROHIBITED INTEREST

No officer, or employee of the City of Agoura Hills shall have any financial interest, direct or indirect, in this Agreement, the proceeds thereof, the Contractor, or Contractor's sub-contractors for this project, during his/her tenure or for one year thereafter. The Contractor hereby warrants and represents to the City that no officer or

employee of the City of Agoura Hills has any interest, whether contractual, non-contractual, financial or otherwise, in this transaction, or in the business of the Contractor or Contractor's sub-contractors on this project. Contractor further agrees to notify the City in the event any such interest is discovered whether or not such interest is prohibited by law or this Agreement.

19. ENTIRE AGREEMENT

This Agreement contains the entire understanding between the parties relating to the obligations of the parties described in this Agreement. All prior or contemporaneous agreements, understandings, representations and statements, oral or written, are merged into this Agreement and shall be of no further force or effect. Each party is entering into this Agreement based solely upon the representations set forth herein and upon each party's own independent investigation of any and all facts such party deems material.

20. AUTHORITY TO EXECUTE THIS AGREEMENT

The person or persons executing this Agreement on behalf of Contractor warrants and represents that he or she has the authority to execute this Agreement on behalf of the Contractor and has the authority to bind Contractor to the performance of its obligations hereunder.

IN WITNESS WHEREOF, the parties hereto have caused this Agreement to be executed the day and year first above written.

CITY OF AGOURA HILLS

Denis Weber,
Mayor

ATTEST:

Kimberly M. Rodrigues, MMC
City Clerk
Date Approved by City Council: _____
To Be Completed by City Clerk

APPROVED AS TO FORM:

Candice K. Lee,
City Attorney

CONTRACTOR

Evolution Audio & Video
5341 Derry Avenue Suite # S
Agoura Hills, CA 91301
Contact Name: Jay Frank
P: 818-879-1312
F: 818-879-0416

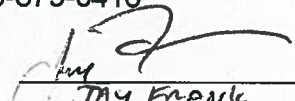
By: 
Name: JAY FRANK
Title: CEO

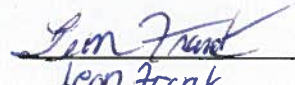
By: 
Name: Leon Frank
Title: CFO

[Signatures of Two Corporate Officers Required]

EXHIBIT A

TASKS TO BE PERFORMED

The specific elements (scope of work) of this service include:

Pre-job walk to confirm final locations, installation techniques, and timelines before work begins.

Install Crestron automated shade system, 194" in height, including programming and final testing. See attached material list for equipment included in this contract.

Work will include the use of lifts, which will require floor protection and rubber tires to ensure that The Event Center floors are protected during installation.

Work will be scheduled during regular business hours, unless otherwise arranged in advance by staff.

Full system will be warranted for one year for all parts/equipment, and labor will be warranted for 90 days from acceptance of completion of job.

Documentation of all new hardware and software information, including any necessary training guides, licensing, portal access, and warranty information.

Conduct final project review with client before closing of project.

EXHIBIT B

PAYMENT RATES AND SCHEDULE

Upon approval of contract, CONTRACTOR can order materials which are expected to take no more than 4-6 weeks for delivery. Once materials have arrived, installation will proceed at a predetermined time as to not impact the daily and/or private activities scheduled for the Recreation and Event Center. Due to the nature of the private rentals, final installation, inspection, and testing of the system should be completed no later than June 30, 2017.

Payment to CONTRACTOR in the amount of \$10,000.00 to be made upon execution of the contract to order materials. Balance of \$49,060.40 to be made at completion of project.

Any change orders or alterations to the quote for services will need to be agreed upon in advance in writing before work commences.

System Equipment

Qty	Item	Description	
1	Crestron	Automated Shade System	\$45,709.92
1	Crestron	Special Crestron Discount	\$ -4,570.99
1	Crestron	Infinite Gateway	\$ 450.00

Total: 41,588.93

Project Tasks and Materials Price

Components and Related Equipment (from above):

Receiver, Preamp, Switchers, etc. \$41,588.93

Installation Materials:

Interconnect Cables, HDMI Cables, Digital Cables, Termination, etc.

\$ 1,000.00

Programming: Shade Automation System \$ 810.00

Rental: (2) 32ft Scissor Lifts \$ 1,520.00

Shipping: \$ 1,188.46

Installation Labor Estimate: \$ 9,120.00

Tax: \$ 3,833.01

TOTAL: \$ 59,060.40



CERTIFICATE OF LIABILITY INSURANCE

DATE (MM/DD/YYYY)

3/3/2017

THIS CERTIFICATE IS ISSUED AS A MATTER OF INFORMATION ONLY AND CONFERS NO RIGHTS UPON THE CERTIFICATE HOLDER. THIS CERTIFICATE DOES NOT AFFIRMATIVELY OR NEGATIVELY AMEND, EXTEND OR ALTER THE COVERAGE AFFORDED BY THE POLICIES BELOW. THIS CERTIFICATE OF INSURANCE DOES NOT CONSTITUTE A CONTRACT BETWEEN THE ISSUING INSURER(S), AUTHORIZED REPRESENTATIVE OR PRODUCER, AND THE CERTIFICATE HOLDER.

IMPORTANT: If the certificate holder is an ADDITIONAL INSURED, the policy(ies) must be endorsed. If SUBROGATION IS WAIVED, subject to the terms and conditions of the policy, certain policies may require an endorsement. A statement on this certificate does not confer rights to the certificate holder in lieu of such endorsement(s).

PRODUCER Ventura Pacific Insurance Services P.O. Box 7447 Thousand Oaks CA 91359	CONTACT NAME: Jamie Rose PHONE (A/C, No, Ext): (805)494-1950 E-MAIL ADDRESS: Jamie@vpisinc.com	FAX (A/C, No): (866)354-4245
	INSURER(S) AFFORDING COVERAGE	
INSURED Lee-J, Inc., DBA: Evolution Audio & Video 5341 Derry Ave #S Agoura Hills CA 91301	INSURER A: Travelers Prop Cas Ins Com	
	INSURER B: United Financial Casualty Co	
	INSURER C: Preferred Employers Insurance	
	INSURER D:	
	INSURER E:	

COVERAGES

CERTIFICATE NUMBER: CL173300447

REVISION NUMBER:

THIS IS TO CERTIFY THAT THE POLICIES OF INSURANCE LISTED BELOW HAVE BEEN ISSUED TO THE INSURED NAMED ABOVE FOR THE POLICY PERIOD INDICATED. NOTWITHSTANDING ANY REQUIREMENT, TERM OR CONDITION OF ANY CONTRACT OR OTHER DOCUMENT WITH RESPECT TO WHICH THIS CERTIFICATE MAY BE ISSUED OR MAY PERTAIN, THE INSURANCE AFFORDED BY THE POLICIES DESCRIBED HEREIN IS SUBJECT TO ALL THE TERMS, EXCLUSIONS AND CONDITIONS OF SUCH POLICIES. LIMITS SHOWN MAY HAVE BEEN REDUCED BY PAID CLAIMS.

INSR LTR	TYPE OF INSURANCE	ADDL INSD	SUBR WVD	POLICY NUMBER	POLICY EFF (MM/DD/YYYY)	POLICY EXP (MM/DD/YYYY)	LIMITS
A	COMMERCIAL GENERAL LIABILITY <input type="checkbox"/> CLAIMS-MADE <input type="checkbox"/> OCCUR GEN'L AGGREGATE LIMIT APPLIES PER: <input type="checkbox"/> POLICY <input type="checkbox"/> PRO-JECT <input type="checkbox"/> LOC OTHER:	X		680-1B945160-16-42	5/23/2016	5/23/2017	EACH OCCURRENCE \$ 2,000,000
	DAMAGE TO RENTED PREMISES (Ea occurrence) \$ 300,000						
B	AUTOMOBILE LIABILITY <input type="checkbox"/> ANY AUTO <input type="checkbox"/> ALL OWNED AUTOS <input type="checkbox"/> HIRED AUTOS <input checked="" type="checkbox"/> SCHEDULED AUTOS <input type="checkbox"/> NON-OWNED AUTOS			03830248-0	6/30/2016	6/30/2017	COMBINED SINGLE LIMIT (Ea accident) \$
	BODILY INJURY (Per person) \$ 250,000						
	UMBRELLA LIAB <input type="checkbox"/> EXCESS LIAB OCCUR CLAIMS-MADE DED RETENTION \$						EACH OCCURRENCE \$
	AGGREGATE \$						
C	WORKERS COMPENSATION AND EMPLOYERS' LIABILITY ANY PROPRIETOR/PARTNER/EXECUTIVE OFFICER/MEMBER EXCLUDED? (Mandatory in NH) If yes, describe under DESCRIPTION OF OPERATIONS below	Y/N <input type="checkbox"/>	N/A	WKN144053-6	7/1/2016	7/1/2017	<input checked="" type="checkbox"/> PER STATUTE <input type="checkbox"/> OTH-ER
	E.L. EACH ACCIDENT \$ 1,000,000						
							E.L. DISEASE - EA EMPLOYEE \$ 1,000,000
							E.L. DISEASE - POLICY LIMIT \$ 1,000,000

DESCRIPTION OF OPERATIONS / LOCATIONS / VEHICLES (ACORD 101, Additional Remarks Schedule, may be attached if more space is required)

The City of Agoura Hills, its officers, officials, employees and volunteers are named as additional insured.

10 Day Notice of Cancellation for Non-Payment of Premium

CERTIFICATE HOLDER**CANCELLATION**

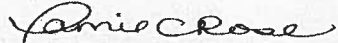
The City of Agoura Hills 30001 Ladyface Court Agoura Hills, CA 91301	SHOULD ANY OF THE ABOVE DESCRIBED POLICIES BE CANCELLED BEFORE THE EXPIRATION DATE THEREOF, NOTICE WILL BE DELIVERED IN ACCORDANCE WITH THE POLICY PROVISIONS. AUTHORIZED REPRESENTATIVE Jamie Rose/JAMIE 
--	---

© 1988-2014 ACORD CORPORATION. All rights reserved.



Quote # 8112713

Rev: 1

Agoura City Hall Rec Center

Date: 7/11/2016

Generated by: Juan Romero

Dealer Info

Company: EVOLUTION AUDIO & VIDEO

Street: 5341 derry ave suite S

City: agoura hills

State: CA

Zip: 91301

Country: US

Contact: Mike Goodman

E-Mail: mike@eavht.com

Phone: 818-879-1312

Customer Info

Customer: Agoura City Hall Rec Center

Street:

City:

State: CA

Zip: 91301

Country: US

Contact: John Treichler

E-Mail:

Phone:

	List Price
Subtotal:	\$45,709.92
Shipping and Handling:	\$1,188.46
Total:	\$46,898.38



Shading Solutions Proposal

Revision Notes

Revision Notes:

Rev.01 - 7/7/16

- All shades that were 180" in height have been revised to 194". No other changes were made.



Shading Solutions Proposal

System Notes

System Notes:

We need another 14in. Since the system will only allow up to 180in, we need a total of 194in.



Shading Solutions Proposal

Bill Of Materials

Crestron Quote: 8112713

Main Hardware

Line Item	QTY	Building	Floor	Room	Tag	Product	System Width	Height	Fabric	MSRP Each	MSRP Extended
1	1	Main	1st	Rec Center	Lower Center	CS/A5/I/250EX	149.6250	106.0000	CSF-27P02-03	\$1,968.18	\$1,968.18
2	1	Main	1st	Rec Center	Lower Center	CS/A5/I/250EX	149.6250	106.0000	CSF-27P02-03	\$1,968.18	\$1,968.18
3	1	Main	1st	Rec Center	Upper Left	CS/A5/I/250EX	149.6250	194.0000	CSF-27P02-03	\$2,282.70	\$2,282.70
4	1	Main	1st	Rec Center	Upper Left	CS/A5/I/250EX	149.6250	194.0000	CSF-27P02-03	\$2,282.70	\$2,282.70
5	1	Main	1st	Rec Center	Upper Center	CS/A5/I/250EX	149.6250	194.0000	CSF-27P02-03	\$2,282.70	\$2,282.70
6	1	Building	1st	Rec Center	Upper Center	CS/A5/I/250EX	151.1250	194.0000	CSF-27P02-03	\$2,282.70	\$2,282.70
7	1	Main	1st	Rec Center	Upper Right	CS/A5/I/250EX	149.6250	194.0000	CSF-27P02-03	\$2,282.70	\$2,282.70
8	1	Building	1st	Rec Center	Upper Right	CS/A5/I/250EX	149.6250	194.0000	CSF-27P02-03	\$2,282.70	\$2,282.70
9	1	Main	1st	Rec Center	Sliding 3 panel	CS/A5/I/250EX	104.6250	106.0000	CSF-27P02-03	\$1,890.42	\$1,890.42
10	1	Building	1st	Rec Center	Sliding 3 panel	CS/A5/I/250EX	104.6250	106.0000	CSF-27P02-03	\$1,890.42	\$1,890.42
11	1	Main	1st	Rec Center	Sliding 4 Panel	CS/A5/I/250EX	139.5000	106.0000	CSF-27P02-03	\$2,330.56	\$2,330.56
12	1	Building	1st	Rec Center	Sliding 4 Panel	CS/A5/I/250EX	139.5000	106.0000	CSF-27P02-03	\$2,330.56	\$2,330.56
13	1	Building	1st	Rec Center	Upper Left	RS/A5/250EX	59.8750	194.0000	CSF-27P02-03	\$1,299.36	\$1,299.36
14	1	Building	1st	Rec Center	Lower Left	RS/A5/250EX	59.8750	106.0000	CSF-27P02-03	\$1,124.18	\$1,124.18
15	1	Building	1st	Rec Center	Upper Right	RS/A5/250EX	59.8750	194.0000	CSF-27P02-03	\$1,299.36	\$1,299.36
16	1	Building	1st	Rec Center	Lower Right	RS/A5/250EX	59.8750	106.0000	CSF-27P02-03	\$1,124.18	\$1,124.18
17	1	Building	1st	Rec Center	Door Left	RS/A5/250EX	47.5000	106.0000	CSF-27P02-03	\$1,017.68	\$1,017.68
18	1	Building	1st	Rec Center	Door Right	RS/A5/250EX	47.5000	106.0000	CSF-27P02-03	\$1,161.68	\$1,161.68
19	2	Building	1st	Rec Center	Tag	CSA-PWS10S-HUB				\$1,760.00	\$3,520.00



Shading Solutions Proposal

Bill Of Materials Cont.

Bill of Materials Cont.:

Line Item	QTY	Building	Floor	Room	Tag	Product	System Width	Height	Fabric	MSRP Each	MSRP Extended
20	1	Main	1st	Rec Center	Lower Center	RS/A5/250EX	49.8750	106.0000	CSF-27P02-03	\$1,036.06	\$1,036.06
21	1	Main	1st	Rec Center	Upper Center	RS/A5/250EX	49.8750	194.0000	CSF-27P02-03	\$1,140.90	\$1,140.90

Accessories

Line Item	QTY	Building	Floor	Room	Tag	Product	Length	Color	MSRP Each	MSRP Extended
22	12	Building	Floor	Room	Tag	QMT5 Series Top/Back Cover	192.0000"	Black	\$288.00	\$3,456.00
23	12	Building	Floor	Room	Tag	QMT5 Series Fascia - Square	192.0000"	Black	\$288.00	\$3,456.00

List Price

Subtotal:	\$45,709.92
Shipping and Handling:	\$1,188.46
Total:	\$46,898.38

Roller Shade

- Hardware Series: Architectural QMT5
- Hardware Finish: White
- Operator Side: LEFT
- Mount: Inside
- Fascia: No Fascia
- Top/Back Cover: No
- End Caps: No
- Side Channel: None

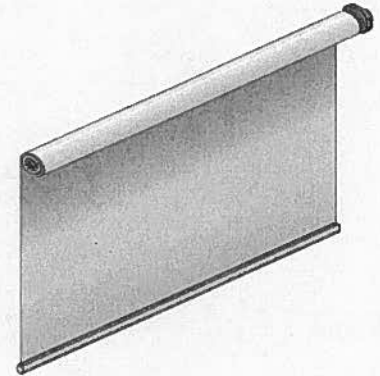

Operator	Tube Size	Interface
QMT250	2.50" SPLINE	-inFINET EX

Roller

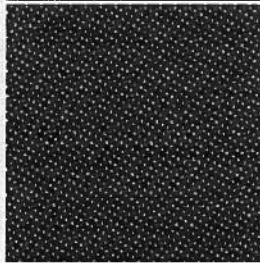

CSF-27P02-03

- Old Fabric p/n: CS-SRH9802-03
- Fabric Color: Oyster/Chestnut
- Openness: 3%
- Dual Sided: Yes
- Color Orientation: Neutral Side To Glass
- Roll Direction: Regular Roll
- Hembar: Open Pocket



Seam Details: N/A
Batten Details: N/A

Line Item	Building	Floor	Room	Tag	Qty	System Width	Specified Width	B to B Width	Fabric Width	Height	Left Light Gap	Right Light Gap	Rail Road	Batn	Seam
13	Building	1st	Rec Center	Upper Left	1	59.8750	B2B	59.8750	58.3750	194.0000	0.7500	0.7500	N	0	0
15	Building	1st	Rec Center	Upper Right	1	59.8750	B2B	59.8750	58.3750	194.0000	0.7500	0.7500	N	0	0
21	Main	1st	Rec Center	Upper Center	1	49.8750	B2B	49.8750	48.3750	194.0000	0.7500	0.7500	N	0	0

Roller Shade

- Hardware Series: Architectural QMT5
- Hardware Finish: White
- Operator Side: LEFT
- Mount: Outside
- Fascia: No Fascia
- Top/Back Cover: No
- End Caps: No
- Side Channel: None

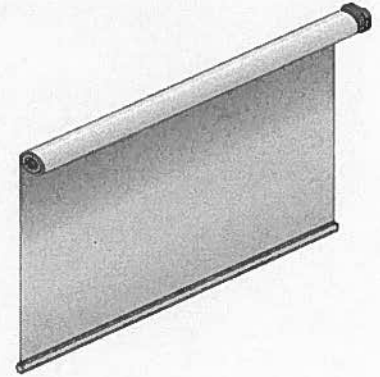

Operator	Tube Size	Interface
QMT250	2.50" SPLINE	MINI EX

Roller

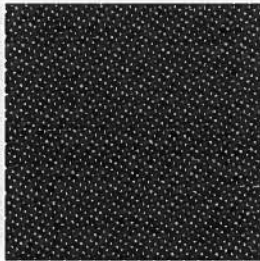

CSF-27P02-03

- Old Fabric p/n: CS-SRH9802-03
- Fabric Color: Oyster/Chestnut
- Openness: 3%
- Dual Sided: Yes
- Color Orientation: Neutral Side To Glass
- Roll Direction: Regular Roll
- Hembar: Open Pocket



Seam Details: N/A
Batten Details: N/A

Line Item	Building	Floor	Room	Tag	Qty	System Width	Specified Width	B to B Width	Fabric Width	Height	Left Light Gap	Right Light Gap	Rail Road	Batn	Seam
14	Building	1st	Rec Center	Lower Left	1	59.8750	B2B	59.8750	58.3750	106.0000	0.7500	0.7500	N	0	0
16	Building	1st	Rec Center	Lower Right	1	59.8750	B2B	59.8750	58.3750	106.0000	0.7500	0.7500	N	0	0

Roller Shade

Hardware Series: Architectural QMT5
Hardware Finish: White
Operator Side: LEFT
Mount: Outside
Fascia: No Fascia
Top/Back Cover: No
End Caps: No
Side Channel: None

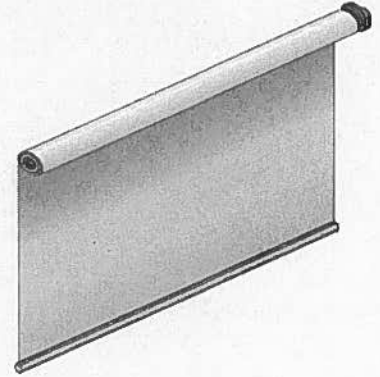

Operator	Tube Size	Interface
QMT250	2.50" SPLINE	infINET EX

Roller

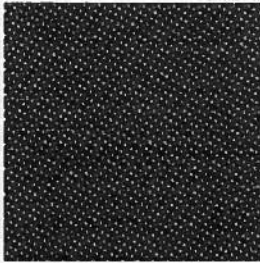

CSF-27P02-03

Old Fabric p/n: CS-SRH9802-03
Fabric Color: Oyster/Chestnut
Openness: 3%
Dual Sided: Yes
Color Orientation: Neutral Side To Glass
Roll Direction: Regular Roll
Hembar: Open Pocket



Seam Details: N/A
Batten Details: N/A

Line Item	Building	Floor	Room	Tag	Qty	System Width	Specified Width	B to B Width	Fabric Width	Height	Left Light Gap	Right Light Gap	Rail Road	Batn	Seam
17	Building	1st	Rec Center	Door Left	1	47.5000	B2B	47.5000	46.0000	106.0000	0.7500	0.7500	N	0	0

Roller Shade

- Hardware Series: Architectural QMT5
- Hardware Finish: Black
- Operator Side: LEFT
- Mount: Outside
- Fascia: No Fascia
- Top/Back Cover: No
- End Caps: No
- Side Channel: None

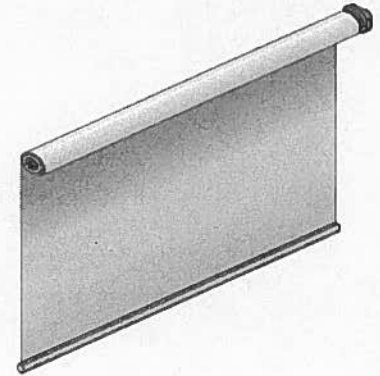

Operator	Tube Size	Interface
QMT250	2.50" SPLINE	TOINET EX

Roller

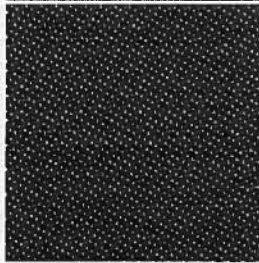

CSF-27P02-03

Old Fabric p/n: CS-SRH9802-03

Fabric Color: Oyster/Chestnut

Openness: 3%

Dual Sided: Yes

Color Orientation: Neutral Side To Glass

Roll Direction: Regular Roll

Hembar: Open Pocket



Seam Details: N/A

Batten Details: N/A

Line Item	Building	Floor	Room	Tag	Qty	System Width	Specified Width	B to B Width	Fabric Width	Height	Left Light Gap	Right Light Gap	Rail Road	Batn	Seam
18	Building	1st	Rec Center	Door Right	1	47.5000	B2B	47.5000	46.0000	106.0000	0.7500	0.7500	N	0	0

Roller Shade

Hardware Series: Architectural QMT5
Hardware Finish: White
Operator Side: LEFT
Mount: Inside
Fascia: No Fascia
Top/Back Cover: No
End Caps: No
Side Channel: None

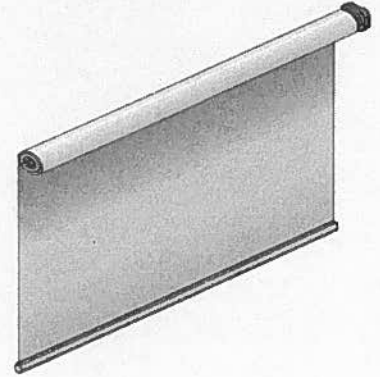

Operator	Tube Size	Interface
QMT250	2.50" SPLINE	InfINET EX

Roller

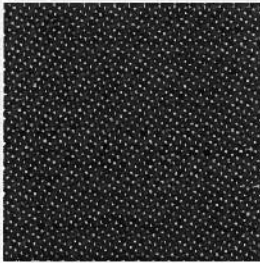

CSF-27P02-03

Old Fabric p/n: CS-SRH9802-03
Fabric Color: Oyster/Chestnut
Openness: 3%
Dual Sided: Yes
Color Orientation: Neutral Side To Glass
Roll Direction: Regular Roll
Hembar: Open Pocket



Seam Details: N/A
Batten Details: N/A

Line Item	Building	Floor	Room	Tag	Qty	System Width	Specified Width	B to B Width	Fabric Width	Height	Left Light Gap	Right Light Gap	Rail Road	Batn	Seam
20	Main	1st	Rec Center	Lower Center	1	49.8750	B2B	49.8750	48.3750	106.0000	0.7500	0.7500	N	0	0

Coupled Roller Shade

Coupler: INLINE
Hardware Series: Architectural QMT5
Hardware Finish: White
Operator Side: LEFT
Mount: Inside
Fascia: No Fascia
Top/Back Cover: No
End Caps: No
Side Channel: None

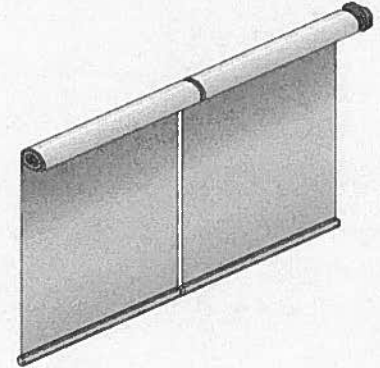

Operator	Tube Size	Interface
QMT250	2.50" SPLINE	MINET EX

Roller

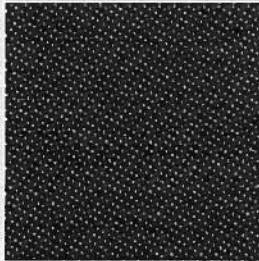

CSF-27P02-03

Old Fabric p/n: CS-SRH9802-03
Fabric Color: Oyster/Chestnut
Openness: 3
Dual Sided: Yes
Color Orientation: Neutral Side To Glass
Roll Direction: Regular Roll
Hembar: Open Pocket



Seam Details: N/A
Batten Details: N/A

Line Item	Building	Floor	Room	Tag	Qty	System Width	Specified Width	B to B Width	Fabric Width	Height	Left Light Gap	Right Light Gap	Rail Road	Batn	Seam
1	Main	1st	Rec Center	Lower Center	1	149.6250	B2B	49.8750	48.3750	106.0000	0.7500	0.7500	N	0	0
								49.8750	48.3750	106.0000	0.7500	0.7500	N	0	0
								49.8750	48.3750	106.0000	0.7500	0.7500	N	0	0
2	Main	1st	Rec Center	Lower Center	1	149.6250	B2B	49.8750	48.3750	106.0000	0.7500	0.7500	N	0	0
								49.8750	48.3750	106.0000	0.7500	0.7500	N	0	0
								49.8750	48.3750	106.0000	0.7500	0.7500	N	0	0



Shading Solutions Proposal Detail Sheet, Cont.

Coupled Roller Shade Cont.:

Line Item	Building	Floor	Room	Tag	Qty	System Width	Specified Width	B to B Width	Fabric Width	Height	Left Light Gap	Right Light Gap	Rail Road	Batr	Seam
11	Main	1st	Rec Center	Sliding 4 Panel	1	139.5000	B2B	34.8750	33.3750	106.0000	0.7500	0.7500	N	0	0
								34.8750	33.3750	106.0000	0.7500	0.7500	N	0	0
								34.8750	33.3750	106.0000	0.7500	0.7500	N	0	0
								34.8750	33.3750	106.0000	0.7500	0.7500	N	0	0

Coupled Roller Shade

- Coupler: INLINE
- Hardware Series: Architectural QMT5
- Hardware Finish: White
- Operator Side: LEFT
- Mount: Inside
- Fascia: No Fascia
- Top/Back Cover: No
- End Caps: No
- Side Channel: None

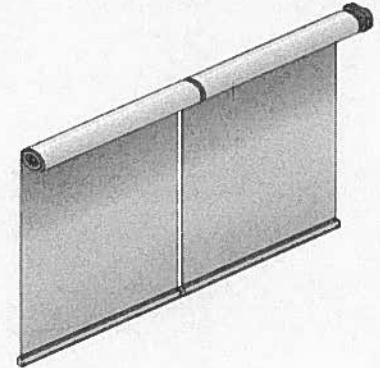

Operator	Tube Size	Interface
QMT250	2.50" SPLINE	inNET EX

Roller

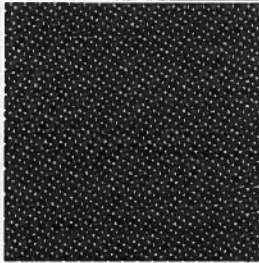

CSF-27P02-03

- Old Fabric p/n: CS-SRH9802-03
- Fabric Color: Oyster/Chestnut
- Openness: 3
- Dual Sided: Yes
- Color Orientation: Neutral Side To Glass
- Roll Direction: Regular Roll
- Hembar: Open Pocket



Seam Details: N/A
Batten Details: N/A

Line Item	Building	Floor	Room	Tag	Qty	System Width	Specified Width	B to B Width	Fabric Width	Height	Left Light Gap	Right Light Gap	Rail Road	Batn	Seam
3	Main	1st	Rec Center	Upper Left	1	149.6250	B2B	49.8750	48.3750	194.0000	0.7500	0.7500	N	0	0
								49.8750	48.3750	194.0000	0.7500	0.7500	N	0	0
								49.8750	48.3750	194.0000	0.7500	0.7500	N	0	0
4	Main	1st	Rec Center	Upper Left	1	149.6250	B2B	49.8750	48.3750	194.0000	0.7500	0.7500	N	0	0
								49.8750	48.3750	194.0000	0.7500	0.7500	N	0	0
								49.8750	48.3750	194.0000	0.7500	0.7500	N	0	0



Shading Solutions Proposal

Detail Sheet, Cont.

Coupled Roller Shade Cont.:

Line Item	Building	Floor	Room	Tag	Qty	System Width	Specified Width	B to B Width	Fabric Width	Height	Left Light Gap	Right Light Gap	Rail Road	Batn	Seam
5	Main	1st	Rec Center	Upper Center	1	149.6250	B2B	49.8750	48.3750	194.0000	0.7500	0.7500	N	0	0
								49.8750	48.3750	194.0000	0.7500	0.7500	N	0	0
								49.8750	48.3750	194.0000	0.7500	0.7500	N	0	0
7	Main	1st	Rec Center	Upper Right	1	149.6250	B2B	49.8750	48.3750	194.0000	0.7500	0.7500	N	0	0
								49.8750	48.3750	194.0000	0.7500	0.7500	N	0	0
								49.8750	48.3750	194.0000	0.7500	0.7500	N	0	0

Coupled Roller Shade

- Coupler: INLINE
- Hardware Series: Architectural QMT5
- Hardware Finish: White
- Operator Side: LEFT
- Mount: Inside
- Fascia: No Fascia
- Top/Back Cover: No
- End Caps: No
- Side Channel: None

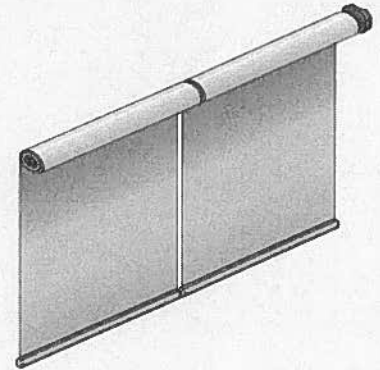

Operator	Tube Size	Interface
QMT250	2.50" SPLINE	INLINE EX

Roller

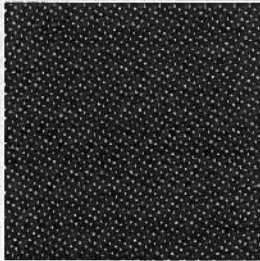

CSF-27P02-03

- Old Fabric p/n: CS-SRH9802-03
- Fabric Color: Oyster/Chestnut
- Openness: 3
- Dual Sided: Yes
- Color Orientation: Neutral Side To Glass
- Roll Direction: Regular Roll
- Hembar: Open Pocket



Seam Details: N/A
Batten Details: N/A

Line Item	Building	Floor	Room	Tag	Qty	System Width	Specified Width	B to B Width	Fabric Width	Height	Left Light Gap	Right Light Gap	Rail Road	Batn	Seam
6	Building	1st	Rec Center	Upper Center	1	151.1250	B2B	50.3750	48.8750	194.0000	0.7500	0.7500	N	0	0
								50.3750	48.8750	194.0000	0.7500	0.7500	N	0	0
								50.3750	48.8750	194.0000	0.7500	0.7500	N	0	0
8	Building	1st	Rec Center	Upper Right	1	149.8250	B2B	49.8750	48.3750	194.0000	0.7500	0.7500	N	0	0
								49.8750	48.3750	194.0000	0.7500	0.7500	N	0	0
								49.8750	48.3750	194.0000	0.7500	0.7500	N	0	0

Coupled Roller Shade

- Coupler: INLINE
- Hardware Series: Architectural QMT5
- Hardware Finish: White
- Operator Side: LEFT
- Mount: Inside
- Fascia: No Fascia
- Top/Back Cover: No
- End Caps: No
- Side Channel: None

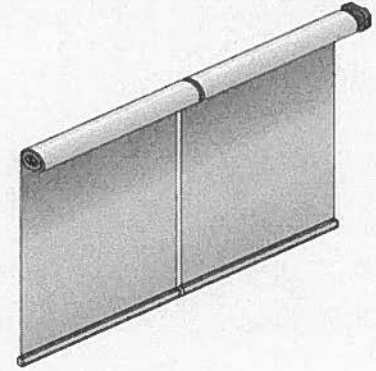

Operator	Tube Size	Interface
QMT250	2.50" SPLINE	MINNET EX

Roller

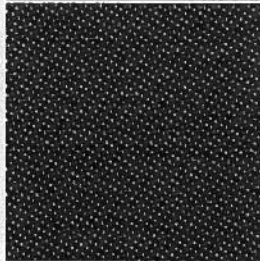

CSF-27P02-03

- Old Fabric p/n: CS-SRH9802-03
- Fabric Color: Oyster/Chestnut
- Openness: 3
- Dual Sided: Yes
- Color Orientation: Neutral Side To Glass
- Roll Direction: Regular Roll
- Hembar: Open Pocket



Seam Details: N/A
Batten Details: N/A

Line Item	Building	Floor	Room	Tag	Qty	System Width	Specified Width	B to B Width	Fabric Width	Height	Left Light Gap	Right Light Gap	Rail Road	Batn	Seam
9	Main	1st	Rec Center	Sliding 3 panel	1	104.6250	B2B	34.8750	33.3750	106.0000	0.7500	0.7500	N	0	0
								34.8750	33.3750	106.0000	0.7500	0.7500	N	0	0
								34.8750	33.3750	106.0000	0.7500	0.7500	N	0	0
10	Building	1st	Rec Center	Sliding 3 panel	1	104.6250	B2B	34.8750	33.3750	106.0000	0.7500	0.7500	N	0	0
								34.8750	33.3750	106.0000	0.7500	0.7500	N	0	0
								34.8750	33.3750	106.0000	0.7500	0.7500	N	0	0



Shading Solutions Proposal Detail Sheet, Cont.

Coupled Roller Shade Cont.:

Line Item	Building	Floor	Room	Tag	Qty	System Width	Specified Width	B to B Width	Fabric Width	Height	Left Light Gap	Right Light Gap	Rail Road	Batn	Seam
12	Building	1st	Rec Center	Sliding 4 Panel	1	139.5000	B2B	34.8750	33.3750	106.0000	0.7500	0.7500	N	0	0
								34.8750	33.3750	106.0000	0.7500	0.7500	N	0	0
								34.8750	33.3750	106.0000	0.7500	0.7500	N	0	0
								34.8750	33.3750	106.0000	0.7500	0.7500	N	0	0

Terms and Conditions:

1. The price on this quote is valid for (90) days. After (90) days, and up to (180) days, all proposals may be subject to an increase of up to 10% to reflect current costs. After (180) days, all proposals must be re-quoted.
2. This quote is limited to supplying the equipment listed herein. Crestron is not responsible for errors or omissions in information it relied upon in preparing this quote, in particular, but not limited to, any errors or inconsistencies in information entered into the CDT.
3. Prices quoted from the CDT are both a suggested list price and a dealer price, they are exclusive of taxes
4. This quote is not a firm offer to sell the indicated products until such time as the quote is converted to an order within the CDT system. Once a Customer has converted a quote to an order, they will receive an order confirmation, which the customer must approve and return to Crestron.
5. Upon acceptance of the approved order confirmation, Crestron will provide an Order Acknowledgment Form. Any changes to the order, requested after the approval of the order confirmation, may be subject to additional charges if production had already begun on the approved order.
6. Once placed, no order may be changed or cancelled by the Purchaser (you) except with the written agreement of Crestron. In the event such a change or cancellation is possible, Purchaser shall indemnify Crestron in full for all costs incurred up to that point to fulfill this order, including but not limited to the cost of all labor and materials used, and any damages, charges and expenses Crestron incurs as a result.
7. All shipments are FOB factory. Estimated freight quoted in this document are for ground transportation only. If any other expedited mode of transportation is requested, applicable charges will be added to the invoice.
8. Payment is due with order unless credit has been approved in advance.
9. After Crestron has provided an Order Acknowledgement Form, the customer may delay (Hold for Release order) the shipment of an order a maximum of 90 days.
 - Hold for Release orders, not released for immediate shipment within 90 days from the date of order acknowledgement, may be subject to a maximum of 10% escalation to cover increased costs.
 - All Hold-for-Release orders, not released for immediate shipment within 180 days from the date of the order acknowledgement, will be subject to a new quotation.
 - Any Hold for Release orders, not released for immediate shipment within one year from the date of order acknowledgement, shall be cancelled and subject to a cancellation charge.
10. Returns may be subject to a restocking charge based upon the product type. Requested returns will be evaluated on a job by job basis to determine the ability to rework or resell the products. Custom items are not returnable unless there is a defect in manufacturers workmanship. All units must be returned unused in the original cartons.



EVOLUTION AUDIO & VIDEO

INNOVATIVE CUSTOM HOME THEATER

Agoura City Hall
Custom Shade Proposal
2-22-17

John Treichler
818-597-7309

Evolution Audio & Video

5341 Derry Avenue Suite S Agoura Hills, CA 91301 818-879-1312 FAX 818-879-0416

Email: jay@eavht.com

Web site: <http://www.eavht.com>

Home Theaters

Music Systems

Custom Design

Installation



February 22, 2017

JT Treichler
City of Agoura Hills
30001 Ladyface Court
Agoura Hills, Ca. 91301

Thank you for contacting Evolution Audio & Video. Attached is a copy of the Evolution Audio & Video description page of our proposal with pricing. Please keep in mind the total systems approach that Evolution Audio and Video is proposing. This offers you unparalleled peace of mind by supplying you:

- State-of-the Art Equipment.
- Highest Quality Pre-Wire Phase.
- Complete High Quality Installation with a Ninety Day, On-Site Warranty in Addition to Manufacturer's Equipment Warranty.
- Instructional Time to explain your System.
- Prompt service available 5 Days a week for Problem Resolution.
- Your complete satisfaction with your new system and Evolution Audio & Video is our only goal.

Selecting Evolution as your audio/video specialists, you are choosing the finest professionals to design and install your home audio & video system. All you have to do is sit back and enjoy the experience. For more information about Evolution Audio and Video and the products we represent, please visit our website at www.eavht.com.

Sincerely,

Jay & Leon Frank

Jay Frank
Leon Frank

Evolution Audio and Video was founded in 1989 by two men and their unending passion for high-end, high-quality audio and video systems. Its founder's, Leon and Jay Frank, are true audio/video iconoclasts whose main goal is to design the finest custom home systems for a discerning clientele.

The key to Evolution Audio and Video's tremendous success is that Leon and Jay have assembled a top-notch team of experienced sales consultants, licensed installers, and a stellar line up of premium electronics such as GoldenEar Technology, Martin Logan, Krell, Cary Audio, PrimaLuna, Stewart Filmscreens, Screen Innovations, Cambridge, Epson, Sony, Integra, Mirage, Kaleidescape, Crestron, URC and many, many more, which truly define the cutting-edge in home entertainment.

In our many years in business, we have not only earned the trust and respect of an exclusive list of discerning clients but also that of the manufacturers we are so very proud to represent, and even that of our peers in this highly competitive industry.

Below please find a short list of extremely satisfied *Evolution Audio and Video* clients whom have benefited from our extensive audio and video knowledge:

Notable Satisfied Customers:

Mr. Gareth Hughes- Universal Studios Executive
Mr. Wolfgang Petersen- Film Director – "Das Boot", "Air Force One"
Mr. Jerry Goldsmith- Hollywood Music Composer
Mr. Joel Goldsmith- Hollywood Music Composer
Mr. Sal Bonafede- Music Producer
Mrs. Barbara Streisand- Entertainer, Actress & Singer
Mr. Mike Lieberthal- Baseball Player
Mr. John Mayall- "Father of the British Blues"
Mr. William Carter- Head Chef Playboy Mansion
Mr. Garrett Lerner- Television Producer – "House"
Mr. Rodney Peete- Football Player
Mr. Dick Wolf- Television Producer – "Law & Order"
Mr. Cary Elwes- Actor
Mr. George Greenberg- Fox Sports
Mr. Dale Rosenbloom- Film Director
Mr. Patrick Lussier- Film Director
Mr. Michael Jay- Music Producer
Mr. John Cusack- Actor
Mr. Robert Smith- Film Producer
Mr. Jeff Stacey – National Sales Director Interscope Records
Lightstorm Entertainment- Movie Production Company
Hollywood Roosevelt Hotel
Dreamworks- Movie Production Company

Scope of Work

Conference Room
Install, Program(?) and Test new automated Shade System.

System Equipment

Family Room			
Qty	Item	Description	
1	Crestron	Automated Shade System	45,709.92
1	Crestron	Special Crestron Discount	-4,570.99
1	Crestron	Infinite Gateway	450.00
Total:			41,588.93

Total Price Summary

Project Tasks and Materials	Price
Components and Related Equipment (from above): Receiver, Preamp, Switchers, etc.	41,588.93
Installation Materials: Interconnect Cables, HDMI Cables, Digital Cables, Termination, etc.	1,000.00
Programming: Shade Automation System	???
Rental: (2) 32ft Scissor Lifts	1,520.00
Shipping:	1,188.46
Installation Labor Estimate:	9,120.00
	Tax: 3,833.01
This proposal is valid for 30 days.	Total: 58,250.40