

PLANNING DEPARTMENT

DATE: September 7, 2017

TO: Planning Commission

APPLICANT: 64North for Mordehai Asaf
5355 Cartwright Avenue, Suite 118
North Hollywood, CA 91601

CASE NO.: CUP-01309-2016

LOCATION: 28439 Foothill Drive (APN 2055-019-037)

REQUEST: Request for approval of a Conditional Use Permit to build a 3,647 square-foot, two-story single-family residence with a 56 square-foot basement, a 627 square-foot attached three-car garage and a 230 square-foot accessory structure; and to make a finding of exemption under the California Environmental Quality Act.

ENVIRONMENTAL DETERMINATION: Exempt from the California Environmental Quality Act (CEQA) per Section 15303 of the CEQA Guidelines.

RECOMMENDATION: Staff recommends the Planning Commission approve Conditional Use Permit Case No. CUP-01309-2016; subject to conditions, based on the findings of the attached Draft Resolution.

ZONING DESIGNATION: Residential Very Low Density – Old Agoura Design Overlay – Equestrian Overlay (RV-OA-EQ)

GENERAL PLAN DESIGNATION: RV (Residential Very Low)

I. PROJECT BACKGROUND AND DESCRIPTION

Will Carson from 64North, representing the applicant, Mordehai Asaf, is requesting the approval of a Conditional Use Permit (CUP) to build a 3,647 square-foot, two-story single-family residence; an attached, 627 square-foot three-car garage; a 56 square-foot basement, and a 230 square-foot accessory structure. The 0.99-acre

lot is located at 28439 Foothill Drive on the north side of the street. A CUP is required because the lot is considered a hillside lot with an average slope of 40 percent. The lot rises 134 feet from the north side of Foothill Drive from an elevation of 1,002 to 1,136 feet at the rear property line. In 2016, the applicant applied for a lot line adjustment to merge two (2) contiguous, vacant lots to form one larger lot, 144-foot wide by 302 feet long, whereas most lots on the street average half that width.

The Lot Line Adjustment was approved by the City in 2016. The lot is vacant and void of protected trees, sensitive flora or important natural features. A single family residence is a permitted use on the Residential Low Density (RV) - Old Agoura Design (OA) and Equestrian (EQ) Overlay zoned lot. The overlay zones ensure compatibility with the neighborhood's rustic and equestrian character. The applicant has agreed to a condition of approval to dedicate the remaining undeveloped portion of the lot as permanent open space. As such, the square footage of this portion can be excluded from the slope average calculation for the hillside lot. Under the Hillside Ordinance, a larger development footprint is permitted in areas with a lower average slope. Whereas the overall average slope is 40 percent, the slope of the proposed development area is only 28 percent.

There are existing homes on all sides of the property. The lot is one of the few remaining vacant lots to be developed on Foothill Drive. The most recent construction is immediately west of this lot, also on a hillside lot, on which the Planning Commission approved a 4,278 square-foot two-story house with a 497 square-foot, attached garage in 2015, construction of which is nearing completion.

The Planning Commission reviews new single-family residential developments on hillside lots, and makes findings for the Conditional Use Permit and hillside development standards.

The following table summarizes how the proposed project compares with the relevant lot and development standards.

| | Existing | Proposed | Allowed/Required |
|------------------------|---------------|---------------|--|
| Lot Dimensions | | | |
| Size (acres) | 0.99 acres | 0.99 acres | 1 acre per RV |
| (square feet) | 43,512 sq.ft. | 43,512 sq.ft. | 43,560 sq.ft. |
| Development Area | N/A | 22,507 sq.ft. | N/A |
| Public St. Frontage | 144 ft. | 144 ft. | N/A |
| Lot Width | 144 ft. | 144 ft. | N/A |
| Lot Depth | 302 ft. | 302 ft. | N/A |
| Building Height | | | |
| Primary Structure | N/A | 27 ft. 7 in. | 35 ft. |
| Secondary Structure | | 10 ft. | 35 ft. in buildable area 14 ft. in setback area |

| | Existing | Proposed | Allowed/Required |
|---------------------------------|----------|-------------------------|--|
| Building Square Footage | | | |
| Main House | N/A | 3,647 sq.ft. | N/A |
| -First Floor | N/A | 1,533 sq.ft. | N/A |
| -Second Floor | N/A | 2,114 sq.ft. | N/A |
| Accessory Structure | N/A | 230 sq.ft. | N/A |
| Total | | 3,877 sq.ft. | |
| Garage | | 627 sq.ft. ¹ | 20 ft. x 20 ft. min. |
| Basement | | 56 sq.ft. ² | N/A |
| TOTAL | | 4,560 sq.ft. | N/A |
| Lot Coverage | | | |
| Structures | | 10.2% | 25 % |
| With Hardscape | | 23.2% | 25% |
| Landscape Coverage | | | |
| | | 29.9% | N/A |
| Building Setbacks | | | |
| Main Structure | | | |
| Front (South) | N/A | 44 ft. | 25 ft. |
| Side (West) | N/A | 31 ft. 10 in. | 12 ft. |
| Side (East) | N/A | 29 ft. | 12 ft. |
| Rear (North) | N/A | 174 ft. 10 in. | 25 ft. |
| Accessory Structure | | | |
| Front (South) | N/A | 129 ft. | 10 ft. |
| Side (East) | N/A | 100 ft. | 5 ft. |
| Side (West) | N/A | 12 ft. | 5 ft. |
| Rear (North) | N/A | 149 ft. | 10 ft. |
| Maximum Floor Area Ratio | | | |
| Lot size 20,001-40,000 sq.ft. | N/A | 3,877 sq.ft. | 4,150 sq.ft x 84% = 3,486 sq.ft. ³ |
| Average Slope | | | |
| Total Lot | 40% | 40% | N/A |
| Developed Area | N/A | 28% | N/A |

II. STAFF ANALYSIS

A. Site Plan and Buildings

¹ The Architectural Design Guidelines exclude a 690 square-foot garage and a basement from the floor area calculations.

² Same as above.

³ The recommended square footage for development area with a 28% slope is reduced by 84% per the Architectural Design Standards and Guidelines.

In keeping with the adjacent properties, the development pad is proposed on the lower and flatter portion of the lot fronting Foothill Drive. This approach avoids greater quantities of cut and fill soil, given that the lot has an overall natural 40 percent slope. This hillside lot has an average topographic elevation of 1,006 feet at the front property line and 1,105 feet at the rear property line. The project proposes a two-story house with the first floor of the house at an elevation of 1,019 feet, which is 13 feet above the street elevation, and a second floor at an elevation of 1,031 feet, or 25 feet above the street. A meandering driveway would be constructed to serve two uncovered guest parking spaces in the front yard and would continue to the side-loaded east-facing garage, at the same topographic elevation as the first floor of the house. The development pad would be terraced and supported by retaining walls. The walls that are proposed in the front yard, in addition to supporting the slope and the driveway, are designed to create landscape planters. Other retaining walls define a useable pad for outdoor activities, level with the first floor. There are retaining walls to support another terraced pad, level with the second floor where a pool and spa could be potentially located along the western side yard and at the same elevation as the first floor roofline. Retaining walls would extend beyond the rear of the structures to support the hillside and provide the 15-foot separation required by the Building Code between the toe of the slope and the structures.

The 230 square-foot accessory structure would be placed above and west of the house at an elevation of 1,039 feet to maintain the view of the hillside south from Foothill Drive. The accessory structure, which includes a bathroom, would serve as a home office for the owners.

With respect to the equestrian use of the property, the plans show a 1,500 square-foot equestrian area on two levels, in the front yard. The applicant considered accommodating an equestrian use on the slope behind the proposed house, however such location would require substantial cut into the hillside and more retaining walls at an elevation above the buildings' roof lines, which would be more visible from Foothill Drive. Locating the equestrian area on the slope above the structures would result in greater visual impacts from the series of retaining walls on the slope and more grading of the steep hillside. An estimated additional 220 cubic yards of soil would need to be imported to the site. The proposed location meets the intent of the Old Agoura and Equestrian Overlay Districts requirements. The project is conditioned to maintain the front yard as a potential equestrian area with no additional structures built other than those for the housing of animals.

The RV zone allows one (1) single-family dwelling unit per lot. The primary structure must be set back a minimum of 25 feet from the front (south) and rear (north) property lines, and 12 feet from each side of the property. The project proposes to build the new two-story single-family structure at 44.25 feet from the front and 174 feet from the rear property line, and about 32 feet from the western and 29 feet from the eastern side property lines, which exceed the minimum requirements for the zone. The structure is positioned at a southwest direction, with the garage oriented toward the east and away from the street. The accessory

structure is over 130 feet from the front property line, 148 feet from the rear property line, 12 feet from the western property line, and 100 feet from the eastern property line, thereby exceeding the minimum required setbacks for an accessory structure.

Per the RV zone, the building site coverage is restricted to 25 percent, whereas the project proposes 10 percent, including the footprint of the house, garage, accessory structure, and impermeable surfaces of the driveway and walkways behind the house. The permeable and semi-permeable surface that are incorporated in the project serve to reduce the runoff and are excluded from the calculations. The Hillside Ordinance adds additional restrictions on the development size based on the slope. Section 9652.2.13 of the Ordinance requires that 77.5 percent of the lot remain as open space based on a 28 percent slope. More discussion is provided in Section C.

Other development standards that affect the design of the project include the overall height of the residence, which the proposed project at 25 feet 7 inches as measured to the top of the roof complies with. The maximum height allowed for a residence in this zone is 35 feet, however, in the case of a hillside lot (over 10 percent slope), the height of the proposed structure is controlled by the elevation line of either the front or rear of the lot. Per Section 9607.1 of the Zoning Ordinance (Hillside), when the rear property line elevation is higher than the front property line, the house is restricted to a maximum 15-foot height at the rear setback line, so as to limit the visual impacts from the street and adjacent off-site areas. Staff calculated the average elevation of the rear setback line at 1,105 feet. The roof line of the house would be at approximately 60 feet lower than the rear setback line elevation and 75 feet below the maximum allowed height of 1,120 feet. The accessory roof line is 55 feet below the rear elevation line and 70 feet lower than the maximum allowed of 1,120 feet. Therefore, both the house and the accessory structure comply with the height requirement.

The project site is within the Equestrian Overlay District (EQ), which requires that a horse-keeping area be identified on the property for equestrian purposes. A 1,500 square-foot horse keeping area has been designated between the driveway and the main residence, but is currently proposed to be used for landscaping. As mentioned earlier in the report, the applicant is challenged with a steep slope behind the house, which if used for equestrian purposes, would require more grading and a system of retaining walls leading to more visual impacts. The proposed horse-keeping area allows for more direct access to the street, facilitating transportation of animals and equipment. The residence was proposed as close as possible to the street to avoid large quantities of grading and lengthy and taller retaining walls. Likewise, grading an equestrian area beyond the house on this slope would create more visual impacts and significantly costlier infrastructure.

The City's Architectural Design Standards and Guidelines have specific recommendations for the Old Agoura residential neighborhood. The guidelines

provide a maximum total square footage for the dwelling unit, garage and other habitable structures in relation to the lot size so that a house is in proportion with the size of the lot. The recommended square footage in the guidelines includes the square footage of all levels, but allows for specific structures and uses such as a front porch and a barn to be excluded from the calculations in order to maintain certain rustic characteristics.

The recommended maximum square footage of the buildings based on the calculations in the Guidelines is 4,150.36 square feet. As proposed, the residence's square footage is 3,647 square feet and the accessory structure is 230 square feet for a total of 3,877 square feet. But because of the slope of the entire parcel, the square footage of the buildings would be reduced by a ratio proportional to the slope percentage. In this case, the development area has a 28 percent slope, which corresponds to a slope ratio factor of 0.84. When applied to the 4,150 maximum recommended square footage, the allowed development size is reduced to 3,486 square feet. Despite the difference between the recommended and proposed square footage (161 square feet), it is unlikely that the project will have impacts on the neighborhood and the Old Agoura area from the size of the structures. The parcel is almost one acre, one-third larger than the parcels (43,512 versus approximately 30,000 square feet) – see below in the neighborhood. The residence's proposed setbacks exceed the zone's minimum required front, rear and sides setbacks and the height is lower than the maximum permitted by almost ten feet. This is a unique project because the proposed home will be placed on a larger parcel with a large expanse of open space to the rear and large setbacks from adjacent properties.

The minimum required size of an RV-zoned lot is one acre (43,560 square feet). The subject lot is 0.99 acres. Therefore, it is a legal nonconforming lot. The lot may still be developed in accordance with the uses and standards of the RV zone pursuant to the City's Nonconforming Use Ordinance Section 9702 of the Municipal Code.

The average size of the RV-zoned lots on the north side of Foothill Drive is 0.7 of an acre or 30,438 square feet. The lots on the south side of Foothill Drive are zoned Residential Low (RL), with a 20,000 square foot minimum lot size required, and average 0.68 of an acre or 29,445 square feet. The residences in the RV-zoned side of Foothill Drive average 2,690 square feet and the residences in the RL-zoned side of Foothill Drive average 2,860 square feet. The project proposes 3,877 square feet of living space on a 0.99 acre.

While there is no floor area ratio (FAR) requirement for this project, the FAR is a useful tool in comparing density. In comparison, neighboring houses have an estimated FAR of 0.088, in the RV zone and 0.097 in the RL zone whereas the proposed project has an FAR of 0.083 and 0.089 including the accessory structure. The project is found to be compatible with the neighborhood.

B. Architectural Design

Zoning Code Sections 9555.B.2 and 9555.C.1 (Old Agoura Design Overlay District) require that projects proposed in Old Agoura embrace an eclectic, rural style that preserve the equestrian nature of the area, and that the design is in character with the existing development within the Old Agoura Overlay District. The Guidelines also provide general recommendations on how to maximize architectural compatibility of new dwelling units with existing residential development, including the height of the structure, natural materials, and colors, roof and eaves, and the preservation of the hillsides and privacy by minimizing grading and maintaining neighborhood scale. The Guidelines also recommend porches and balconies, rear or side facing garage doors, front door visibility, generous roof overhangs and roof variations, use of natural materials like wood and stone, warm and rich colors, and use of windows, porches, balconies, trellises and terraces to help create free flowing space to the outdoors, along with respecting landforms on site.

The buildings are sited on the lot to not block views to the south from adjacent homes and to ensure privacy for adjacent residences. To the east, a dense row of existing trees on the subject site serves as a buffer to the neighboring residence. Views from the neighboring residence would be of the landscaped front yard. The proposed residence would be situated behind the residence under construction on the parcel to the west, not directly aligned with the house, and therefore maximizing the morning light into the house to the west.

The Architectural Review Panel (ARP) reviewed the project. The ARP requested that a rendering of the residence be provided for the benefit of the Planning Commission. The ARP suggested the number of barrel roofs on the front elevation be reduced and more stone and natural materials be applied to the accessory structure to be more compatible with the single-family home. The applicant revised the plans in response. A rendering is attached to this report.

The architectural style and the construction materials reflects a high quality design with simple elements of curves, barrel forms, solid planes and accent screens, compatible with the surrounding natural environment in shape and form. Materials include an eclectic mix of stone, rustic brick, glass, wood, standing seam metal roof, concrete and metal railings. The color scheme is muted and earth tone, with the use of natural materials like wood, stone and brick, along with metal accents and large glass windows, which would be non-reflective surfaces. Other residences in the neighborhood are stuccoed with a Spanish tiles roof or clad with wood siding with concrete tile roof also with earth tones.

The new structures are in proportion with the lot size and neighboring structures as discussed in Item A. Site Plan and Buildings, and are substantially lower in height than the maximum allowed. The second floor of the house is set back from the first floor, thereby reducing the impacts of the mass on the surrounding vistas. The roof is designed with four barrels of various lengths, built out of standing seam

metal that provides an undulating and varied roof. The barrels vary in length and extend four to six feet beyond the building facade to provide shade over the first floor flat roof built to serve as a terrace. The front elevation provides large windows with a top row of small windows designed to follow the curve of the roof. The remainder of the facades are clad with dark red brick veneers and wood screen accents. The windows and doors are framed with a fire-resistant wood that projects from the walls and softens the look of the brick. The facade design reflects the use of the interior space, and is recessed where there is no need for additional living space. The garage is side-loaded and east facing, with wooden doors. The roof curves imitate the rolling hills outline of the surrounding hillsides. The eclectic style of the design elements and use of materials fit within the neighborhood character, which consists of diverse architectural styles and forms, and materials.

The accessory structure, which would be located closer to the natural slope is designed with a low profile flat roof, and the façades are clad with stone to blend in with the open space. The front elevation has four (4) patio doors designed to swing outward to the right to provide access outside and provide views. Other windows are provided on each side elevation as tall as the patio doors with wood frames to add architectural interest. A sliding wood screen is provided on the front elevation to screen the patio doors for privacy. The result is a highly efficient designed space like the main house, and interactive with the outdoor space.

C. Hillside

The parcel is subject to the hillside development standards of the Zoning Ordinance (Section 9652.15.A) because its slope is in excess of ten (10) percent. The Zoning Ordinance establishes special regulations in hillside areas to protect them from incompatible development, and preserve the natural terrain, quality environment and aesthetic character while encouraging creative innovative and safe residential development. The hillside development standards address how tall a structure can be in relation to the elevation of a front or rear property line. A structure cannot exceed 15 feet in height at the rear setback line when the topographic elevation of the rear property line is higher than the front yard property line. The proposed house would be two-story and would not exceed the average elevation at the rear setback line of the ascending slope.

The standards also quantify the percent of developable versus undeveloped open space area. The amount is determined by the slope of the lot. In this case, the parcel has an applicable slope of 28 percent, and as a result, 22.5 percent of the parcel can be developed and 77.5 percent must remain undeveloped. This ratio translates into 9,790 square feet of developable area which is less than the proposed development pad, and 33,712 square feet of open space area, which this project could not comply with given the proposed 21,005 square feet undeveloped area. The Hillside Ordinance stipulates that, in the event these open space limitations would prohibit development of the parcel for residential use, a residential dwelling unit shall be permitted as long as the parcel was legally created, sewer service is provided, and a CUP is granted. The project meets these

necessary criteria and the terms under which the project is conditioned. The lot can be developed with a single-family residence while avoiding development on the steeper slopes. In 2016, the owner merged two contiguous lots to create the single lot. The applicant has minimized the house footprint by concentrating the development near the street and preserving the slopes in their natural state. The lot will maintain 21,005 square feet of permanently dedicated open space where the lot is the steepest (Condition No. 24 Attachment 1, Exhibit A). The dedicated open space is connected to adjacent open space areas, which acts as a natural buffer between developments. No natural feature or landmark will be removed or impacted by the larger development pad.

The Hillside Ordinance advocates protecting view-sheds, minimizing erosion, using native or other plant species that blend naturally with the landscape, and building design standards. The building design standards include variation in roof massing, low roof pitch that follow the hillside slope, avoiding large expanses of a single material on walls, creating interesting and small-scale patterns by breaking up building masses and varying building materials, providing architectural treatment to all sides of a building, and using materials and colors that blend with the natural landscape. The project is consistent with these criteria as discussed in Item B. Architectural Design. The site layout preserves views from existing adjacent residences by the lower building height and location of structures on the site in relation to neighboring buildings.

D. Equestrian Overlay District

The purpose of the Equestrian Overlay District is to create, enhance, and protect the equestrian and rural atmosphere within the overlay area. A minimum 1,500 square feet horse keeping area shall be provided for stabling and servicing horses. The area shall be fairly level and shall be accessible by vehicles for emergency services to the animals. Furthermore, the area shall take into consideration the location and size of the anticipated structures so as to comply with minimum setbacks to structures designed for human living. Although the owners are not interested in keeping horses, the project architect has shown areas in the front yard on two terraced pads retained by walls as a designated equestrian area that could be easily modified and used as an equestrian area. Both areas connect to an unobstructed path that leads to a driveway, which complies with the minimum size and access requirements of the Equestrian Overlay. The designed area provides sufficient setback to habitable structures to accommodate shade structures as well. A condition was added (Condition No. 25 Attachment 1 Exhibit A) to preserve an area in the front yard with equestrian related structures only so that this area is not later developed with non-horse keeping structures.

E. Old Agoura Design Overlay District

The Old Agoura Design Overlay District is intended to perpetuate Old Agoura's unique rustic character. Residential development shall embrace an eclectic, rural style that preserves the equestrian nature of the area. The architectural style of

the project is eclectic and is in harmony with the surroundings. Furthermore, the project complies with all the standards of the underlying RV zone (see Item B Architectural Design) despite the challenging topography. The proposed landscaping will screen the residence and the retaining walls from the street.

The project includes semi-permeable surface as much as the development standards will allow it by using pervious pavers near the garage where the ground is level and a combination of decomposed granite, interspersed with stepping concrete tiles around the house for the walking surfaces. The impermeable surfaces are required for the structures, staircases, and retaining walls in addition to the driveway, which is designed to comply with the Los Angeles County Fire Department's requirements.

F. Homeowners Association

A letter, dated May 4, 2017, from the Old Agoura Homeowners Association regarding the project is included as Attachment 3.

G. Public Works/Engineering Department

The preliminary Grading Plan has been reviewed by the City Public Works/Engineering Department. The project proposes an estimated 645 cubic yards of cut soil, 925 cubic yards of fill, and 280 cubic yards of import soil. The Public Works/Engineering Department has conditioned the project (Condition No. 47 in Exhibit A of Attachment 1) to pave the street the width of the property, which is a minimum requirement for the road improvements and to provide adequate vehicular access for the fire department. Drainage is contained on site to avoid flooding in the street in the event of heavy rain. The project would be required to comply with Low Impact Development standards to ensure proper drainage and water quality. The erosion control methods include the use of retaining walls to avoid excessive grading of the hillsides and the slopes that will be graded to transition between the natural open space and the structures will be landscaped and maintained with an efficient irrigation system to control erosion. The flat surfaces will be covered with permeable and semi-permeable surfaces to increase absorption of rain and irrigation water and limit runoff. The project would connect to the existing public sewer system, which was recently extended to the parcel by the property owner to the west.

H. Landscaping

The applicant has provided a Landscape Plan that includes a combination of native and non-native but drought tolerant species, consisting of trees and grasses. Several existing Eucalyptus trees along the eastern property line would remain and continue to provide privacy to the existing residence on the adjacent property. Condition No. 80 of Exhibit A, Attachment 1 requires that grasses identified on the landscape plan behind the structures be of native species to integrate the project with its natural environment. The Landscape Plan is subject to the approval by

Los Angeles County Fire Department Fuel Modification Division, which has reviewed the plans and provided a preliminary approval.

I. General Plan Consistency

Staff finds the project will be consistent with the following applicable General Plan goals and policies:

Goal LU-7 Livable and Quality Neighborhoods. Neighborhoods that provide a variety of housing types, densities, and design, and a mix of uses and services that support the needs of their residents.

- Policy LU-7.1 Neighborhoods Conservation. Maintain the uses, densities, character, amenities, and quality of Agoura Hills' residential neighborhoods, recognizing their contribution to the City's identity, economic value, and quality of life for residents.
- Policy LU-7.2 Housing Character and Design. Require that new and renovated housing within existing single- and multi-family neighborhoods be located and designed to maintain their distinguishing characteristics and qualities, including prevailing lot sizes; building forms, scale, massing, and relationship to street frontages; architectural design; landscape; property setback; and comparable elements. Continue to implement the City's Architectural Design Standards and Guidelines to ensure that residential units are designed to sustain the high level of architectural design quality and the character of the existing lands forms that characterize the Agoura Hills neighborhoods, in consideration of the following principles as identified in the Standards and Guidelines.
 - Harmony with the natural land forms and native vegetation
 - Response to the local climate (through proper building orientation, appropriate glazing, use of overhangs, shading devices, native vegetation, etc.)
 - Reflection of the highest standards of adjacent buildings and the neighborhood style[s], proportions, colors, and materials.

Goal LU-8 Residential Very Low and Residential Low Density Neighborhood (Old Agoura). Residential neighborhoods containing very low-and low-density housing reflecting Agoura Hills' history and designed to respect their environmental setting.

- Policy LU-8.1 Neighborhood identify. Maintaining the low density, rustic character of large estates lots.
- Policy LU-8.2 Development Compatibility with Community Character. Maintaining the development scale in relation to the lot size.
- Policy LU-8.3 Integration of Development with Natural Setting. Designing structures in harmony with the hillside to protect ridgelines.

- Policy LU-8.4 Property Setbacks. Maintaining varying front and side yards' setbacks.
- Policy LU-8.5 Building Materials and Colors. Using materials that are used in rural zones.
- Policy LU-8.6 Landscaping. Creating a natural transition between the existing and the new landscaping.
- Policy LU-8.7 Open Spaces. Maximizing the open space areas to preserve the equestrian use of the land.

The project complies with Goals LU-7 and LU-8. The project would be consistent with neighboring properties in terms of height, density, setbacks and protection of slopes. The lot size is similar to, and in some cases, larger than, the neighboring lots, and while the building square footage may be more than neighboring properties, the lot size and therefore the ratio of development to land area is less than or similar to other properties. The project works with the landforms by utilizing terracing, and the steeper portion of the lot is due to be preserved as open space.

The architectural design is of high quality, as are the materials, which are muted and have natural tones, reflecting a rustic theme. The proposed barrel roof forms of the residence echo the slope across the hillside. The roof of the accessory structure, set behind the house, is flat and of limited profile to minimize its silhouette against the hillside. This structure would be composed of mostly stone, further blending in with the natural hillside behind.

The buildings are adequately articulated with varying architectural features and planes, in particular with the overhanging barrel roof forms on the second story. The different building façade materials (rustic brick, wood, metal, glass, concrete and stone) and features, including balconies and terraces, minimize the building mass.

The plant palette incorporates native as well as non-native but natural-looking trees and plant species. A condition has been incorporated to require the grass species shown on the Landscape Plan behind the structures and adjacent to the open space hillside to be native.

The project preserves the neighborhood identity of Old Agoura by maintaining a small scale development similar to other properties in the ratio of development to lot size. The project maintains the development pattern of the area, by keeping the development pad to a minimum, including the access, and at the same time provides sufficient vehicle parking on site. The structures are set back over 40 feet from the public access. Hardscape is minimized on the property to just provide enough required access for the delivery of emergency services and access to the garage, the necessary walking paths and retaining walls. The remainder of the development pad would be landscaped or covered with pervious pavers and decomposed granite.

Goal LU-9 Single Family Neighborhoods. Maintenance of the identity, scale and character of the City's distinct residential neighborhoods.

- Policy LU-9.1 Neighborhood Identity. Maintain the distinguishing characteristics that differentiate by topography, parcel size, housing scale and form, and public streetscapes in Agoura Hills' single-family neighborhoods.

The project complies with Goal LU-9 and Policy LU-9.1 by remaining in scale with, or being less dense than, the other residences in the neighborhood in terms of the relationship of the home size to the lot size. The yard setbacks exceed those of most of the other existing development on the same street and the Old Agoura residential neighborhood. The building heights are less than the maximum allowed in the zone, 25 feet 7 inches for the residence and 11 feet for the accessory structure, versus 35 feet and 14 feet allowed respectively. The development would be half of the entire lot in with the other half left as open space. The deep front yard allows the slope to be terraced providing space for rows of trees to screen the structures and planting at the bases of the retaining walls to screen them. As such, the development would not be readily visible from passers-by.

J. Environmental Review

The project has been reviewed pursuant to the California Environmental Quality Act (CEQA), and has been determined to be Categorical Exempt from the CEQA Guidelines per Section 15303. This exemption includes the construction of new structures, including a single-family residence and accessory structures. No significant environmental impacts are expected from development of this project. No exception to this categorical exemption applies, as set forth in Section 15300.2 of the CEQA Guidelines, including but not limited to, subsection (c) which relates to unusual circumstances that could have a significant effect on the environment.

III. RECOMMENDATION

Based on the foregoing analysis, staff recommends that the Planning Commission approve CUP-01309-2016, subject of conditions of approval, based on the findings of the attached Draft Resolution.

IV. ATTACHMENTS

1. Draft Conditional Use Permit Resolution with Exhibit A Conditions of Approval
2. Letter from the Old Agoura Homeowners Association
3. Vicinity/Zoning Map
4. Rendering and Color and Material Board
5. Reduced Copies of the Project's Architectural, Civil, and Landscape Plans
6. Photographs of the Property

Case Planner: Valerie Darbouze

DRAFT RESOLUTION NO. _____

A RESOLUTION OF THE PLANNING COMMISSION OF THE CITY OF AGOURA HILLS, CALIFORNIA, APPROVING CONDITIONAL USE PERMIT CASE NO. CUP-01309-2016 FOR THE CONSTRUCTION OF A SINGLE-FAMILY RESIDENCE AT 28439 FOOTHILL DRIVE; AND MAKING A FINDING OF EXEMPTION UNDER THE CALIFORNIA ENVIRONMENTAL QUALITY ACT.

THE PLANNING COMMISSION OF THE CITY OF AGOURA HILLS, CALIFORNIA, HEREBY FINDS, RESOLVES, AND ORDERS AS FOLLOWS:

Section I. An application was duly filed by 64North for Mordehai Asaf with respect to the real property located at 28439 Foothill Drive (Assessor's Parcel Number 2055-019-037), requesting the approval of a Conditional Use Permit (Case No. CUP-01309-2016) to construct a 3,647 square-foot, two-story, single-family residence with an attached, 627 square-foot three-car garage, a 56 square-foot basement, and a 230 square-foot accessory structure.

Section II. The project is a request for one single-family residence and is exempt from the California Environmental Quality Act (CEQA), per CEQA Guidelines Section 15303(a) (New Construction or Conversion of Small Structures). The project would not have a significant effect on the environment because it does not exceed the maximum allowable number of structures on one parcel, is not located in an environmentally sensitive area, and the project construction and occupation would otherwise not constitute a significant environmental impact. No exception to this categorical exemption applies as set forth in Section 15300.2 of the CEQA Guidelines, including but not limited to subsection (c) which relates to unusual circumstances.

Section III. The Planning Commission of the City of Agoura Hills considered the application at a public hearing held on September 7, 2017 at 6:30 p.m. in the City Hall Council Chambers, City Hall, 30001 Ladyface Court, Agoura Hills, California. Notice of the time, date, place and purpose of the aforesaid hearing was duly given.

Section IV Evidence, both written and oral, including the staff report and supporting documentation, was duly presented to and considered by the Planning Commission at the aforesaid public hearing.

Section V Conditional Use Permit. Based on the evidence presented at the public hearing, including the staff report and oral and written testimony, the Planning Commission finds, pursuant to the Agoura Hills Municipal Code Section 9673.2.E, that:

A. The proposed use, as conditioned, is consistent with the objectives of the Zoning Ordinance and the purposes of the district in which the use is located. The proposed project is located within the Very Low Density Residential–Old Agoura Design Overlay-Equestrian Overlay (RV-OA-EQ) zoning district, which allows for the development of single-family residences. The City's minimum development standards have been met for the zoning district with regard to lot coverage, building height, and building setbacks from the property lines.

B. The proposed use, as conditioned, is compatible with the surrounding properties. The proposed building design and building materials of the residence, which include stucco and rustic brick veneer exterior walls, along with wood screens and wood frames around the windows, metal railing, and a standing seam metal roof, are compatible with the neighboring structures. The architecture is consistent with the neighborhood in terms of harmonizing with the hillside, lower profile buildings below the maximum allowed height, roof variation and forms reflecting hills, and building articulation, and the topography of the property. The residence is to be located in the lower, flatter portion of a sloped lot to minimize grading and to reduce visual impacts as viewed from Foothill Drive. The project is in compliance with the City's Architectural Design Guidelines and Standards pertaining to the placement of the building and the access proposed in the direction of the contour lines of the hillside. The architectural style is compatible with the eclectic and natural environment, designed in an eco-friendly manner to serve the interior function of the house, and increased interaction with the outdoors. The project maintains the potential for the development of the equestrian use of the lot.

C. The proposed use, as conditioned, and the conditions under which the project will be operated or maintained will not be detrimental to the public health, safety or welfare, in that the proposed use will ensure adequate light, air and privacy, and open space to surrounding properties. The proposed residence is situated in the lower, flatter portion of the site, which will preserve the views and privacy of the surrounding properties. The project complies with the maximum allowable building height limitations of hillside properties and setback to ascending slopes. Preliminary geological, geotechnical, and drainage studies, as well as preliminary landscape plans, have been provided and approved by the City's Consultants. Vehicular access to the property will be provided via Foothill Drive. The project will be served by a sewer system. The applicant is required to construct the project in full compliance with the City's Building Code.

D. The proposed use, as conditioned, will comply with each of the applicable provisions of the Zoning Ordinance. The project complies with the development standards of the underlying zone relative to the required lot coverage (23.2 percent provided, 25 percent maximum allowed), building height, and building setbacks. The project is consistent with the Hillside Ordinance,

which allows for the construction of one single-family home and accessory structures, and will be terraced into the hillside. Although the open space square footage is less than the required area for the overall hillside lot, over 20,000 square-foot area of the lot will be preserved from development as dictated by the terms of this Conditional Use Permit. The structures are placed close to the road and will preserve views of the hillside from the road and from the existing neighboring residential structures.

E. The distance from other similar and like uses is sufficient to maintain the diversity of the community in that the project will meet the minimum yard setback requirements for the RV zone. The residence will be placed an appropriate distance from Foothill Drive, to preserve public views. The project is within an existing single-family residential neighborhood. The distance to the closest off-site structure is approximately 24 feet to the west and 31 feet to the east. The eclectic and unique style of the home adds to the diversity of the neighborhood.

F. The proposed use, as conditioned, is consistent with the City's General Plan. The project complies with Goal LU-7 and LU-8. The project would be consistent with neighboring properties in terms of height, density, setbacks and protection of slopes. The lot size is similar to, and in some cases, larger than, the neighboring lots, and while the building square footage may be more than neighboring properties, the lot size and therefore the ratio of development to land area is less than or similar to other properties. The project works with the landforms by utilizing terracing, and the steeper portion of the lot is due to be preserved as open space. The architectural design is of high quality, as are the materials, which are muted and have natural tones, reflecting a rustic theme. The building is adequately articulated with recessed walls, with the second floor set back from the first floor, and architectural features such as the proposed barrel roof forms of the residence, which echo the slope across the valley. The roof of the accessory structure, set behind the house, is flat and of limited profile to minimize its silhouette against the hillside. The accessory structure would be placed higher on the slope and would be clad with stone to blend in with the natural hillside behind. The plant palette incorporates native as well as non-native but natural-looking trees and plant species. A condition has been incorporated to require the grass species shown on the Landscape Plan behind the structures and adjacent to the open space hillside to be native.

The project preserves the neighborhood identity of Old Agoura by maintaining a small scale development similar to other properties in the ratio of development to lot size. The project maintains the development pattern of the area by keeping the development pad to a minimum, including the access, and at the same time provides sufficient vehicle parking on site. The structures are set back over 40 feet from the public access, which adds to the variety of front yard setback on the north side of the street. Hardscape is minimized on the property to just provide enough required access for the delivery of emergency services and access to the

garage, the necessary walking paths and retaining walls. The remainder of the development pad would be landscaped or covered with pervious pavers and decomposed granite. The project complies with Goal LU-9 and Policy LU-9.1 by remaining in scale with, or being less dense than, the other residences in the neighborhood in terms of the relationship of the home size to the lot size. The yard setbacks exceed those of most of the other existing development on the same street and the Old Agoura residential neighborhood. The building heights are less than the maximum allowed in the zone, 25 feet 7 inches for the residence and 11 feet for the accessory structure, versus 35 feet and 14 feet allowed respectively. The development would allow half of the parcel to remain as open space. The deep front yard allows the slope to be terraced providing space for rows of trees to screen the structures and planting at the bases of the retaining walls to screen them. As such, the development would not be readily visible from passers-by.

Section VI. Hillside Development. The Planning Commission finds, pursuant to Section 9652.15.A of the Agoura Hills Municipal Code, which establishes special regulations for hillside development areas, that:

A. The project is located and designed so as to protect the safety of current and future community residents, and will not create significant threats to life and/or property due to the presence of geologic, seismic, slope instability, fire, flood mud flow, erosion hazards or other hazards. The project is conditioned to comply with the Low Impact Development (LID) requirements of the Code to protect storm water quality and drainage. A preliminary geotechnical report has been approved by the City Geotechnical Consultant. Final geotechnical reports are required for review by the City prior to grading permit issuance. The Engineering/Public Works and Building and Safety Departments have reviewed the project and imposed conditions to ensure the project would be consistent with safety requirements and would not pose a threat to life or property.

B. The proposed project is compatible with the natural, biotic, cultural, scenic and open space resources of the area. The project development is situated on the lower, flatter site portion and does not protrude above any ridgelines. There are no General Plan designated ridgelines on or adjacent to the lot. The development will not significantly block neighbors' views given the location of the buildings proposed on the lower, flatter area and the building height of each structure (25 feet 7 inches and 11 feet), which, in each case, is less than the maximum allowed. No protected natural resource exists on the site and therefore no resource is expected to be impacted. Conditions to protect biological and cultural resources, if encountered during construction, are incorporated into the project conditions of approval. The large open space area in the steeper hillside area is to be preserved in its natural state to act as a natural buffer between residential lots and a condition has been incorporated into the project requiring the preservation of this area as open space.

C. The project can be provided with essential public services and is consistent with the objectives and policies of the City general plan. All utility services will be brought to the parcel without interference with the existing infrastructure. The property is required to connect to the public sewer system similar to the adjacent properties.

D. The development will complement the community character and benefit current and future community residents. The proposed size of the house in relation to the lot size is consistent with neighboring homes. The project is low profile, less than the allowed maximum height. Materials and colors are rustic and muted types. Terraces and overhanging curved roof elements echo the hillside. The unique design is well-articulated and the effects of the building massing are reduced accordingly. The project conforms with the code requirements and adds to the diversity of the neighborhood, reflecting an eclectic style encouraged by the Old Agoura Design Standards and Guidelines. A large portion of the lot is to be preserved as open space and left in its natural state.

E. The development as conditioned, is consistent with the general design and construction standards set forth in the Hillside Ordinance, including standards for density, view preservation, fire protection, erosion control, drainage control, ridgelines, building design and landscaping. The project complies with all aspects of the Hillside Ordinance and is subject to the terms of the Conditional Use Permit pertaining to the open space requirements including the agreement to Condition No. 24 and Section 9652.12.B and 13.B. No primary or secondary ridgeline is identified in the General Plan in the general area of the project so no visual impact will result from the project.

Section VII. Based on the aforementioned findings, the Planning Commission hereby approves Conditional Use Permit Case No. CUP-01309-2016, subject to the attached conditions as Exhibit A, with respect to the property described in Section 1 hereof.

Section VIII. The Secretary of the Planning Commission shall certify to the passage, approval, and adoption of this resolution, and shall cause this resolution and this certification to be entered in the Book of Resolutions of the Planning Commission of the City.

PASSED, APPROVED and ADOPTED this September 7, 2017, by the following vote to wit:

AYES: (0)
NOES: (0)
ABSENT: (0)
ABSTAIN: (0)

Curtis Zacuto, Chairperson

ATTEST:

Doug Hooper, Secretary

CONDITIONS OF APPROVAL
(Case No. CUP-01309-2016)

PLANNING DEPARTMENT

1. This decision, or any aspect of this decision, can be appealed to the City Council within fifteen (15) days from the date of Planning Commission action, subject to filing the appropriate forms and related fees.
2. The approval of this permit shall not be effective for any purpose until the applicants have agreed in writing that they are aware of, and accept, all conditions of this permit with the Department of Planning.
3. Except as modified herein, the approval of this action is limited to and requires complete conformance to the labeled exhibits: Site Plan, Building Elevation Plans, Floor Plan, Roof Plan, Grading Plans, and Landscape Plan.
4. All exterior materials used in this project shall be in conformance with the materials samples submitted as a part of this application.
5. It is hereby declared to be the intent that if any provision of this permit is held or declared invalid, the permit shall be void and the privileges granted hereunder shall lapse.
6. It is further declared and made a condition of this action that if any condition herein is violated, the permit shall be suspended and the privileges granted hereunder shall lapse; provided that the applicant has been given written notice to cease such violation and has failed to do so for a period of thirty (30) days.
7. All requirements of the Zoning Ordinance and of the specific zoning designation of the subject property must be complied with unless set forth in this permit or on the approved Site Plan.
8. No occupancy shall be granted for any new building until all conditions of approval have been complied with as determined by the Planning Director.
9. A minimum of two (2) enclosed parking spaces shall be provided on the subject property, in conformance with the City Parking Ordinance. A minimum interior clear space of 20 feet by 20 feet must be maintained within the garage.
10. All structures shall conform to the requirements of the Building and Safety Department of the City of Agoura Hills.
11. The applicant shall comply with the requirements of the Los Angeles County Fire Department prior to the issuance of Building or Grading Permits. The Forester and Fire Warden shall be consulted to ascertain the required fire flows and fire hydrants to accommodate the proposed development.

12. Unless this permit is used within two (2) years from the date of City approval, Conditional Use Permit Case No. CUP-01309-2016 will expire. A written request for a one (1) year extension may be considered prior to the expiration date.
13. The applicant shall pay to the City the applicable General Plan Update Recovery Fee prior to the issuance of a Building Permit. The current fee is \$1.41/\$1,000 of building valuation. Actual fees will be determined at the time of building permit issuance.
14. The applicant shall comply with the school impact fee requirements of the Las Virgenes Unified School District. The current fee is \$3.48 per square foot for residential construction.
15. No roof-mounted equipment, other than attic ventilation systems and solar panels, as allowed by the Municipal Code, shall be permitted.
16. All outstanding fees owed to the City, if any, shall be paid by the applicant within thirty (30) days from the date of this approval.
17. In the event archaeological resources are encountered during ground-disturbing activities, the City Planning Department shall be notified immediately, and work shall stop within a 100-foot radius until a qualified archaeologist approved by the City Planning Department, and retained and paid for by the developer/applicant, has assessed the nature, extent, and potential significance of any remains pursuant to the California Environmental Quality Act (CEQA). In the event such resources are determined to be significant, appropriate actions are to be determined by the archaeologist consistent with CEQA (PRC Section 21083.2) and the City General Plan, in consultation with the City Planning Department.
18. If human remains are unearthed during ground disturbing activities, State Health and Safety Code Section 7050.5 requires that no further disturbances shall occur until the County Coroner has made the necessary findings regarding origin and disposition pursuant to the Public Resources Code Section 5097.98. If human remains are unearthed, the developer/contractor shall contact the City Planning Department and County Coroner immediately. If the remains are determined to be of Native American descent, the Coroner has 24 hours to notify the Native American Heritage Commission (NAHC). The NAHC will then identify the person(s) thought to be the Most Likely Descendent (MLD) of the deceased Native American, who will then help determine what course of action should be taken in dealing with the remains. If an archaeologist and/or a Native American representative is needed to assess the remains and determine a course of action, all such fees and expenses shall be the responsibility of the developer/contractor and not the City.
19. Final Fuel Modification Plan approval by the County Fire Department Fuel Modification Unit is required prior to issuance of a Building Permit.

20. It is the responsibility of the applicant and/or his or her representatives to report to the City any changes related to any aspects of the construction prior to undertaking the changes.
21. A pre-construction conference shall be held prior to the issuance of a Grading Permit, with all construction personnel involved with the grading operations.
22. If substantial changes are made to the approved Preliminary Landscape Plan, as determined by the Planning Director, the revised Landscape Plan shall be subject to approval by the Planning Commission.
23. The Applicant, and property owner(s), and their successors in interest, shall indemnify, defend and hold harmless the City, its officials, officers, agents and employees (collectively "Indemnitees") from and against any and all claims, actions, lawsuits, damages, losses and liabilities arising or resulting from the granting of this approval by the City or the exercise of the rights granted by this approval. This indemnification obligation shall include, but not be limited to, paying all fees and costs incurred by legal counsel of the City's choice in representing the Indemnitees in connection with any such claims, actions or lawsuits, any expert fees, and any award of damages, judgments, verdicts, court costs or attorneys' fees in any such claim, action or lawsuit. The City shall promptly notify Applicant and property owners of any claim, action, or proceeding and the City shall reasonably cooperate in the defense. In the event such a legal action is filed, the City shall estimate its expenses for litigation. Applicant or property owners shall deposit such amount with the City or enter into an agreement with the City to pay such expenses as they become due. Applicant and property owners shall reimburse the City, and each of the Indemnitees for any and all legal expenses and costs incurred by it in enforcing the indemnity herein provided. Although the Applicant is the real party in interest in an action, the City may, at its sole discretion, participate in the defense of the action, but such participation shall not relieve the Applicant of any obligation under this condition.
24. The property owners agree to preserve the areas of the lot above the 1,050-foot topographic elevation line as permanent open space. The property owners shall record a land conservation easement against the property, satisfactory in form to the Planning Director. Evidence of such recordation shall be provided to the satisfaction of the Planning Director prior to issuance of a grading permit or building permit, whichever occurs first.
25. The property owners agree to maintain an equestrian area in the front yard of 1,500 square feet, as identified in the site plan, and construct structures only for the purpose of serving an equestrian use except for the pool and spa on the second level.
26. The accessory structure approved with this permit shall not be used as an accessory dwelling unit unless otherwise permitted by the City of Agoura Hills.

BUILDING AND SAFETY

27. The applicant shall comply with the Very High Fire Hazard Severity Zone (VHFHSZ) requirements, as outlined in Chapter 2 of Article VIII in the Agoura Hills Municipal Code (AHMC), for all exterior materials used for eaves, sidings, porch, patio, decks, carport and other similar structures.
28. The project plans shall demonstrate a two percent (2%) slope away from the structure for drainage (on the first 5 feet) all around the new structure(s).
29. The applicant shall submit a soil report to the Building and Safety Department along with the construction plans during the plan check process.
30. The applicant shall note on the final plans that all new or replaced windows will be tempered on at least one side of the dual pane, or a 20 minimum-rated window or glass blocks per Section 704A.3.2.2 of the 2016 California Building Code.
31. This project is subject to the 2016 California Building, Mechanical, Plumbing, Electrical, and Energy Green Building Codes and Agoura Hills Municipal Code as such, all plans and reports shall comply with the latest requirements specified in these codes.
32. The construction plans shall comply with AQMD Rule 445 whereby only fireplaces fueled by gas (such as gas logs) may be installed in a new residence. Permanently installed indoor or outdoor wood-burning fireplaces or stoves are not permitted.
33. The applicant is required to install fire sprinklers per Section 903.2, Article VIII of the Agoura Hills Municipal Code 903.2 for the proposed project.
34. The applicant shall install handrails for exterior stairs with four (4) or more risers per the 2016 California Residential Code Section 311.7.8.
35. The project shall comply with the Hillside setbacks requirements specified in the Agoura Hills Municipal Code Section 1805.3.2.
36. The project shall be subject to the review and approval of the Los Angeles County Fire Department required for all new structures and site related improvements prior to the issuance of a Grading Permit.
37. The applicant shall demonstrate that the project complies with the pool safety fencing requirements. If utilizing the perimeter fencing for this purpose, the fence must comply with all pool safety measures, including but not limited to, the fence height, type, gates and doors' latch and swing.
38. The applicant shall obtain the approval of the Las Virgenes Municipal Water District prior to issuance of a Building Permit.

39. The applicant shall demonstrate compliance with the Las Virgenes School District by paying the required fees based on livable square feet. The approved fee per square feet is \$3.48.
40. The construction plans shall demonstrate that all bedrooms have an egress window that meets the requirement of the 2016 California Residential Code.

ENGINEERING/PUBLIC WORKS

41. Prior to permitting, all required plans and studies shall be prepared by a Registered Professional Engineer in the State of California, and submitted to the City Engineer for review and approval.
42. For all work within the public right-of-way, the applicant shall obtain an Encroachment Permit. Prior to issuance of this permit, all public improvement plans, which include but are not limited to, street, water, sewer, storm drain, lighting, signing and striping shall be reviewed and approved by the City Engineer. Water plans shall be designed to meet LVMWD standards and contain a signature block for the City Engineer. All associated fees and securities shall be based upon completed Engineering Cost Estimate forms, approved by the Engineering Department. Forms are available for download from the City's website at www.ci.agoura-hills.ca.us.
43. Applicant shall pay all applicable Transportation Impact Fees (TIF) to the Building and Safety Department prior to the issuance of the grading permit of \$3,094.
44. All existing street and property monuments within or abutting this project site shall be preserved consistent with AB1414. If during construction of onsite or offsite improvements, monuments are damaged or destroyed, the applicant shall retain a licensed land surveyor or civil engineer to reset those monuments per City's Standards and file the necessary information with the County Recorder's office.
45. Detailed on-site utility information shall be shown on the grading plan, which includes, but is not limited to, backflow prevention devices, exact location of laterals, water meter size and location, invert elevations and grades for all gravity lines. The grading plan will not be approved by the Engineering Department until this detailed utility information is included on the plans.
46. The Grading Plan shall show locations of all Oak trees, if any, within the vicinity of the site. Applicants shall adhere to all requirements pertaining to Oak trees as outlined in the City's Oak Tree Consultant's conditions of approval, if any.
47. Prior to permitting, the applicant shall submit a soils/geology report to the project engineer for review and approval in accordance with Government Code, Section 66434.5 as required by the City Engineer.

48. Building Permits shall not be issued until the applicant has obtained a permit from Los Angeles County Fire Department and Las Virgenes Municipal Water District for water and sewer connection.
49. Prior to permitting, the applicant shall provide a title report not older than 30 days.
50. Building Permits shall not be issued until graded building pad(s) have been certified for compaction and elevation to the City's satisfaction. The applicant shall contact the City Engineering Department at (818) 597-7322 for approved City certification forms.
51. Prior to permitting, all public improvements shall be designed in accordance with City Code, Specifications, approved Specific Plan, and/or approved Conditions of Approval for the area. The applicant shall widen the asphalt concrete and install a rolled curb along the property frontage, install a chip seal driveway approach, and construct a sewer lateral for connection, and all water appurtenances shall be per LVMWD standards.
52. The following existing street being cut for new services or being finished with curb and gutter may require an asphalt concrete overlay: Foothill Drive along the property frontage.
53. This property is within the Las Virgenes Municipal Water District (LVMWD) service area. The applicant shall make arrangements with LVMWD for those services and provide the City with proof that all LVMWD fees have been paid.
54. Applicant shall connect to existing 8-Inch sewer line in Foothill Drive.
55. Applicant shall use existing laterals, whenever provided, for connection to the public sewer system.
56. All water facilities shall be designed to comply with all LVMWD requirements. Final plans must be reviewed and approved by LVMWD and City.
57. Applicant shall submit a hydrology study and drainage analysis, prepared and signed by a Civil Engineer registered in the State of California, in accordance with the Los Angeles County Hydrology Manual, is required. Additional drainage facilities or portions of the site/grading plan may need to be altered as a result of the findings of this study.
58. Prior to the approval of the Grading Plan and issuance of Grading Permit, a completed Low Impact Development (LID) Plan shall be submitted to and approved by the Engineering Department. The LID Plan shall comply with the requirements of the LID Ordinance and Los Angeles County LID Standards Manual. The LID Plan shall include the following information:

- Identification of whether the proposed project is a Designated or Non-Designated Project.
 - If the proposed project is a Designated Project, identification of the project category.
 - Feasibility of infiltration including a percolation report as part of a geotechnical report prepared by a geotechnical engineer.
 - Source control measure(s) proposed to be implemented
 - Calculation of the SWQDv.
 - Discussion on whether stormwater runoff harvest and use is feasible.
 - Stormwater quality control measure(s) proposed to be implemented.
 - Discussion of how the applicable water quality standards and total maximum daily loads (TMDLs) will be addressed (off-site mitigation projects only).
 - Proposed hydromodification controls and calculations (if necessary).
 - Proposed maintenance plan (if necessary).
59. Prior to the approval of the Grading Plan and issuance of Grading Permits, an Erosion and Sediment Control Plan (ESCP) shall be submitted to and approved by the Engineering Department. The Erosion and Sediment Control Plan shall specifically identify the Best Management Practices (BMPs) that will be implemented on this project, during construction, to reduce the discharge of sediment and other pollutants into the City's storm drain system. Said plan shall ensure, among other things, that the following minimum requirements are effectively implemented at all construction sites:
- a. Sediments generated on the project site shall be retained using adequate Treatment Control or Structural BMPs;
 - b. Construction-related materials, wastes, spills, or residues shall be retained at the project site to avoid discharge to the streets, drainage facilities, receiving waters, or adjacent properties by wind or runoff;
 - c. Non-storm water runoff from equipment and vehicle washing and any other activity shall be contained at the project site;
 - d. Erosion from slopes and channels shall be controlled by implementing an effective combination of BMPs such as the limiting of grading scheduled during the wet season; inspecting graded areas during rain events; planting and maintenance of vegetation on slopes and covering erosion susceptible slopes.
60. Prior to the approval of the Grading Plan and issuance of Grading Permits, a completed Standard Urban Storm Water Mitigation Plan (SUSMP) shall be submitted to and approved by the Engineering Department. The SUSMP shall be prepared per the Los Angeles County Standard Urban Storm Water Mitigation Plan (SUSMP) design guidelines. SUSMP shall identify, among other things, all Post-Construction, Site Design, Source Control and Treatment Control Best Management

Practices (BMPs) that will be incorporated into the development project in order to minimize the adverse effects on receiving waters.

61. All remaining fees/deposits required by the Engineering Department must be paid in full prior to issuance of grading permit.
62. All requirements including construction of improvements covered in Condition No. 50 must be completed to the satisfaction of the City Engineer.
63. The applicants' Engineer shall submit a set of MYLAR, Record (as-built) Drawings, for off-site improvements, to accurately reflect the constructed improvements. This set of Record Drawings reflecting all change orders during construction, must be submitted to the City for City's inspection prior to scheduling of final inspection for acceptance of the improvements. No final inspection will be scheduled and subsequently no release of securities, posted for the project if any, will take place unless MYLAR, Record (as-built) Drawings, satisfactory to the City, are submitted.
64. The applicants shall record a covenant for continued storm water maintenance, using City-approved forms, with the Los Angeles County. An electronic copy of this document is available on the City's website: www.agoura-hills.ca.us.
65. All monuments shall be set in accordance with the final map, and all centerline ties shall be submitted to the Engineering Department. Any monuments damaged as a result of construction, shall be reset to the City's satisfaction.
66. Upon receiving the Title Report, if conflicts/issues arise regarding recorded documents over property, applicant shall take all measures necessary, as directed by the City Engineer, to resolve said conflicts/issues. All conditions are to be complied with to the satisfaction of the City Engineer in accordance with the applicable provisions of the Agoura Hills Municipal Code.
67. No gravel is permitted in the right-of-way.

GEOTECHNICAL

68. The applicant shall comply with all the City Geotechnical Consultant's (GeoDynamics, Inc.) Conditions of Approval letter dated June 28, 2017, incorporated herein by this reference.

LANDSCAPING

69. The Final Landscape Plans shall substantially conform to the Landscape Preliminary Plan prepared by Morrison Mays Landscape Architecture as approved by the City of Agoura Hills Planning Commission.
70. Prior to the approval of a grading permit, the applicant shall submit three (3) sets of Final Landscape and Irrigation Plans for review by the City Landscape Consultant

and approval by the Planning Director. A California – licensed Landscape Architect shall prepare, stamp and sign the plans. The Plans shall be submitted with a copy of the following approved plans: Architectural Site Plan, Building Elevations and Final Grading Plan. Conditions of Approval shall also be submitted with the Landscape and Irrigation Plans. The Landscape and Irrigation Plan shall meet the requirements of the State Model Water Efficient Landscape Ordinance and Division 8, Chapter 6, Article IX of the Agoura Hills Municipal Code.

71. At the time of the Final Landscape Plans submittal, the project Landscape Architect shall provide the City with written confirmation that he/she has reviewed the civil engineering drawings and that the Landscape Plan is not in conflict with the requirements of the National Pollutant Discharge Elimination System (NPDES) and Low Impact Development Standards (LID).
72. Planting Plans shall indicate the botanical name, the plant container sizes and spacing. The minimum size of trees shall be 15 gallons. The minimum size of shrubs shall be five (5) gallon except shrubs planted as groundcovers and or as accent planting, which may be one (1) gallon size. Plant sizes may be increased on some projects at the discretion of the Planning Director. Plant symbols shall depict 75 percent of the size of the plant at maturity. Palm trees are not permitted in the City of Agoura Hills. All plant material shall be compatible with Sunset's Climate Zone 18.
73. The Final Landscape Plans shall include the following notes:
 - a. The project Landscape Architect shall inspect and certify in writing that the landscape installation is in conformance with the approved Landscape Plans.
 - b. Identification of the total square footage of the landscape area within the project.
74. The Final Irrigation Plans shall be provided separate from, but utilizing the same format as, the Planting Plans. The Final Irrigation Plans shall include calculations that demonstrate the irrigation design hydraulically works given the static and working design pressure of the system.
75. With the Final Landscape Plans, three (3) copies of planting and irrigation details and specifications shall be provided, addressing but not limited to, planting, soil preparation, tree staking, guying, instillation details and post installation maintenance.
76. The approved landscaping shall be continually maintained in a healthy state. Plants that die and plants that are damaged shall be immediately replaced with originally specified material.
77. Invasive non-native plants that can threaten the local wildland ecosystems are not permitted. These plants are listed in the California Invasive Plant Inventory published by the California Invasive Plant Council.

78. The Final Landscape Plan shall be approved by the Fuel Modification Unit of the County of Los Angeles Fire Department prior to the issuance of a building permit.
79. Landscaping and irrigation installation shall be subject to inspection and approval by the Planning Department prior to final building permit inspection.
80. Plant species adjacent to the on-site open space area including grasses identified in the landscape plan to remain shall be native to the area.

FIRE DEPARTMENT

81. The applicant shall comply with all conditions of the Los Angeles County Fire District prior to the issuance of a grading and a building permit, whichever comes first.

SOLID WASTE MANAGEMENT

82. To ensure that solid waste generated by the project is diverted from the landfill and reduced, reused, or recycled, the applicant shall submit a "Waste Reduction & Recycling Plan" to the City for review and approval. The plan shall provide for at least 50% of the waste generated on the project to be diverted from the landfill. Plans shall include the entire project area, even if tenants are pursuing or will pursue independent programs. The plan shall be submitted to and approved by the Department of Planning and Community Development prior to issuance of a building permit. The plan shall include the following information: material type to be recycled, reused, salvaged, or disposed; estimated quantities to be processed, management method used, and destination of material including the hauler name and facility location. The City's Waste Reduction & Recycling Plan form or a similar format shall be used.
83. The project shall comply with the plan and provide for the collection, recycling, and/or reuse of materials (i.e. concrete, wood, metal, cardboard, green waste, etc.) and document results during demolition and/or construction of the proposed project. After completion of demolition and/or construction, the applicant shall complete a Waste Reduction & Recycling Summary Report and provide legible copies of weight tickets, receipts, invoices or letters of verification for materials sent to disposal or reuse/recycling facilities. For other discarded or salvaged materials, the applicant shall provide documentation, on the disposal facility's letterhead, identifying where the materials were taken, type of materials, and tons or cubic yards disposed, recycled or reused and the project generating the discarded materials. The Waste Reduction & Recycling Summary Report shall be submitted and approved prior to issuance of a certificate of occupancy, or final inspection if issuance of a certificate of occupancy is not applicable.
84. The applicant shall arrange for materials collection during construction, demolition, and occupancy with a City permitted hauling company, or shall arrange for self-hauling to an authorized facility.

END

Old Agoura Home Owners Planning and Zoning Committee

May 4, 2017

Attn: City of Agoura Hills Planning Dept.

Re: 28439 Foothill. Asaf Residence

The Planning and zoning committee, from the Old Agoura Home Owners Planning committee has reviewed the revised plans by 64 North Architect, dated March 1, 2017. Please refer to our previous letter dated, December 18th for further clarification. We respectfully submit the following:

The proposed roof, was partially redesigned from the original version. One of the smaller "humps" was eliminated, and was replace with a larger one, reducing the "humps" from 5, to 4. Additionally, the water proofing membrane was replace with standing seam sheet metal.

Wood type trim was added to the front elevation around the windows for articulation, also, some wood shutter/horizontal details were added to the accessory structure.

The horse keeping area was relocated.

The committee is split on our findings.

- 1- Mike Colabella believes the front has a "commercial/library feel", and notes "The property is not being developed equine farm animal friendly"
- 2- Phil Ramuno likes it, supports it: Noting the project is terraced, and works well with the land. Also, pursuant to our meeting with the applicant's architect, the revisions identified herewith, mitigated our concerns from our December 18th letter; therefore the project warrants approval.
- 3- I, Daniel Farkash believe, the house, and the accessory building, violates our guidelines. I also believe the revisions presented, have not substantially changed from the original drawings submitted. Therefore, it is my opinion, the issues noted on our December 18th letter, have not been addressed.

These are some of the guidelines, and references for development within the Old Agoura overlay.

9553.6. - Required architectural style and building materials.

Project design and development shall perpetuate and reinforce the natural character of Old Agoura.

9555. B #3 Residential development shall not render property untenable for horses and other farm animals.

9555- C, The proposed design is in character with existing development in the Old Agoura District, in terms of height, materials, colors, roof pitch, roof eaves, and the preservation of privacy.

Given our split decision, we ask to Staff, and the Planning Commission to review the aforementioned. Determine, if the project as originally presented, and or the revision made by the applicant, merit approval.

Thank you,
Old Agoura Homeowners Planning and Zoning Committee.

Phil Ramuno
Daniel Farkash -
Mike Colabella

City of Agoura Hills

Conditional Use Permit Case No. CUP-01309-2016

Vicinity/Zoning
Map

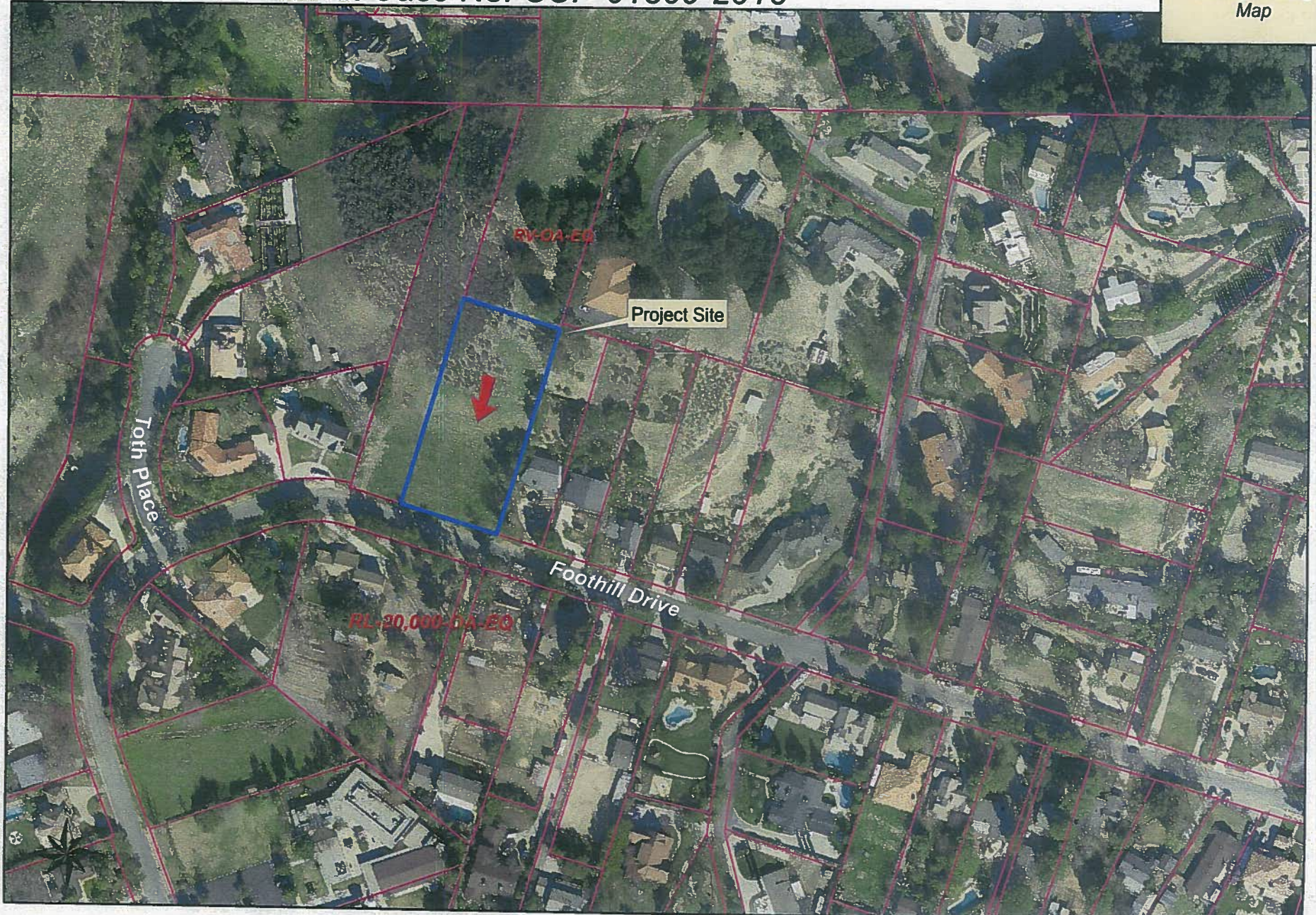

AERIAL VIEW FROM SOUTH



VIEW FROM SOUTHWEST ON FOOTHILL DRIVE



SOUTH ELEVATION & ENTRY



VIEW FROM EAST



VIEW FROM WEST



28439 FOOTHILL DRIVE

COLOR & MATERIAL BOARD
28 JULY, 2017

719 N FAIRFAX AVE, SUITE C
LOS ANGELES, CALIFORNIA 90046
T + I 310 923 0813 F + I 310 933 0550
INFO@64NORTH.COM

64NORTH



1. Chip Seal Paving

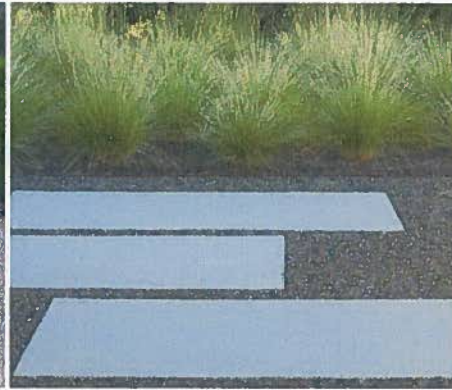

2. Concrete Pavers in Gravel



3. Stone Wall with Cobble Blanket



4. Stone Wall and Stair



5. Gravel Stair with Steel Edging



6. Reflection Pool



7. Rustic Red Brick



8. Beige Stucco



9. Satin Grey Window/Sliding Door Frames



10. Slatted Teak Window Projections



11. Metal Guardrail



12. Standing Seam Roof

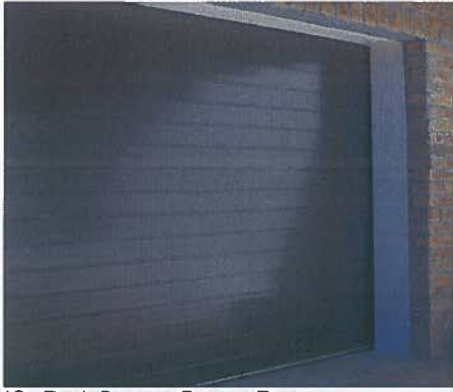

13 . Dark Bronze Garage Door



14. Concrete Stair

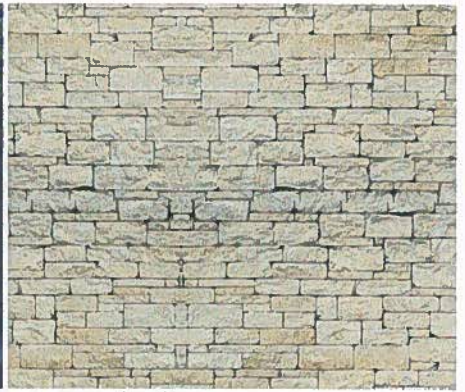

15. Stone Cladding



16 . Wood Brise Soleil



17 . Rustic CMU Wall

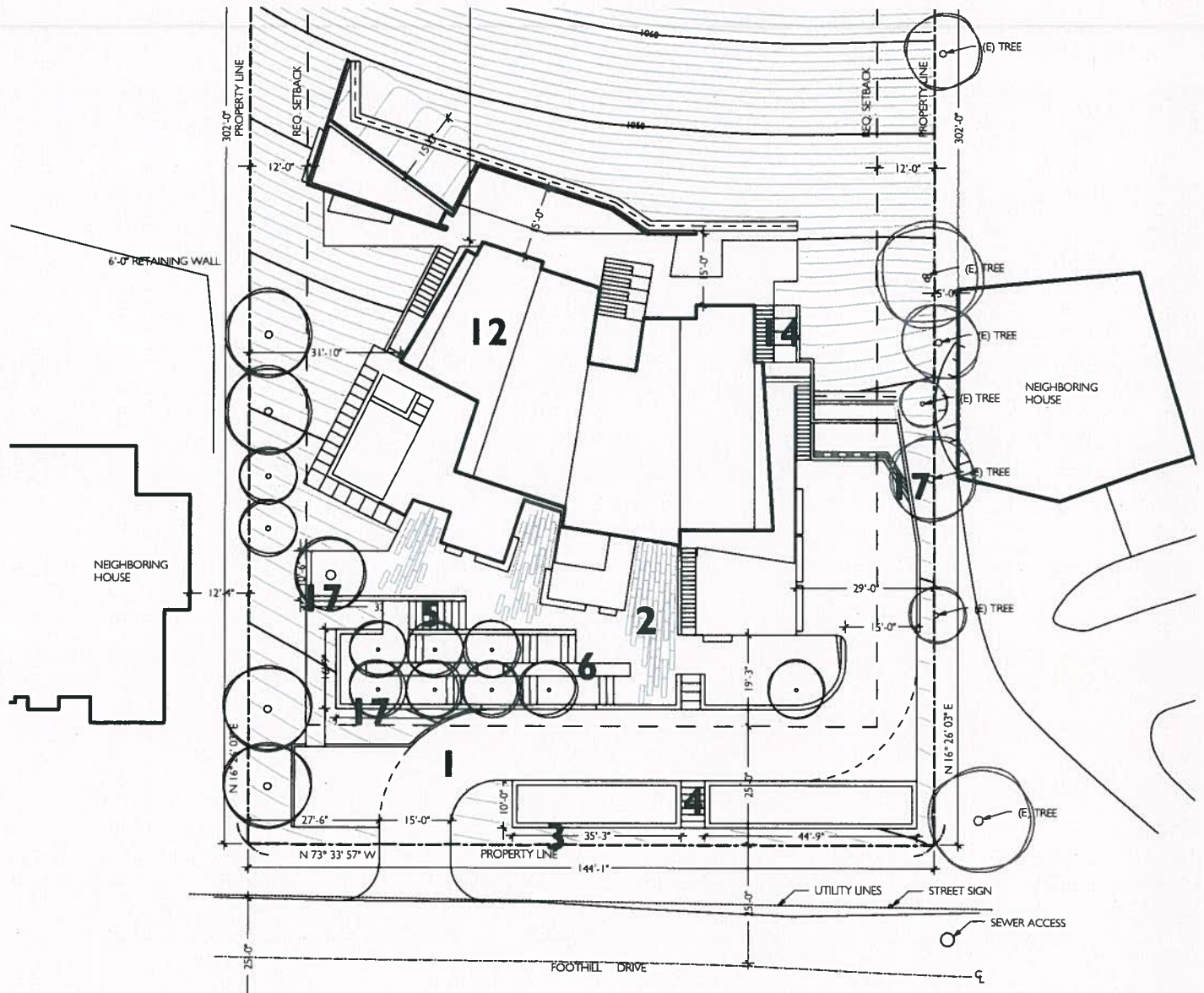

MATERIALS & FEATURES

- 1. Natural Chip Seal Paving
- 2. Concrete Pavers in Gravel
- 3. Stone Wall with Cobble Blanket
- 4. Stone Wall and Stair
- 5. Gravel Stair with Steel Edging
- 6. Reflection Pool
- 7. Rustic Red Brick
- 8. Beige Stucco
- 9. Satin Grey Window/Sliding Door Frames
- 10. Slatted Teak Window Projections
- 11. Metal Guardrail
- 12. Beige Roof Membrane
- 13. Slatted Teak Garage Door
- 14. Concrete Stair
- 15. Stone Cladding
- 17. Rustic CMU Wall

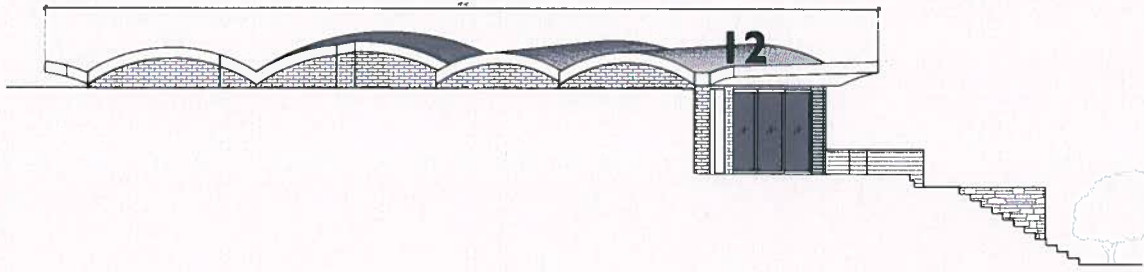

12 NORTH ELEVATION
Wing

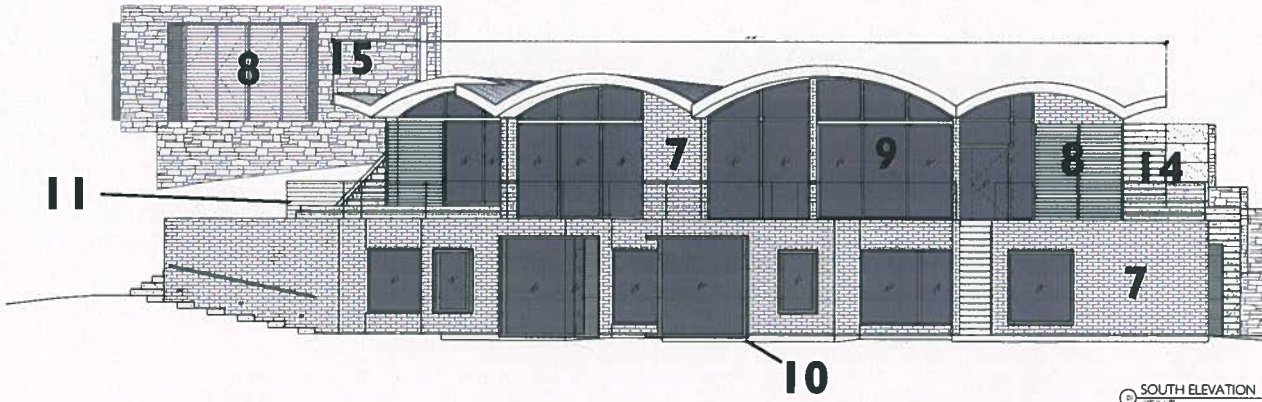

10 SOUTH ELEVATION

MATERIALS & FEATURES

1. Natural Chip Seal Paving
2. Concrete Pavers in Gravel
3. Stone Wall with Cobble Blanket
4. Stone Wall and Stair
5. Gravel Stair with Steel Edging
6. Reflection Pool
7. Rustic Red Brick
- 8 Wood Brise Soleil
9. Satin Grey Window/Sliding Door Frames
- 10 . Slatted Teak Window Projections
11. Metal Guardrail
12. Standing Seam Roof
- 13 . Slatted Teak Garage Door
14. Concrete Stair
15. Stone Cladding

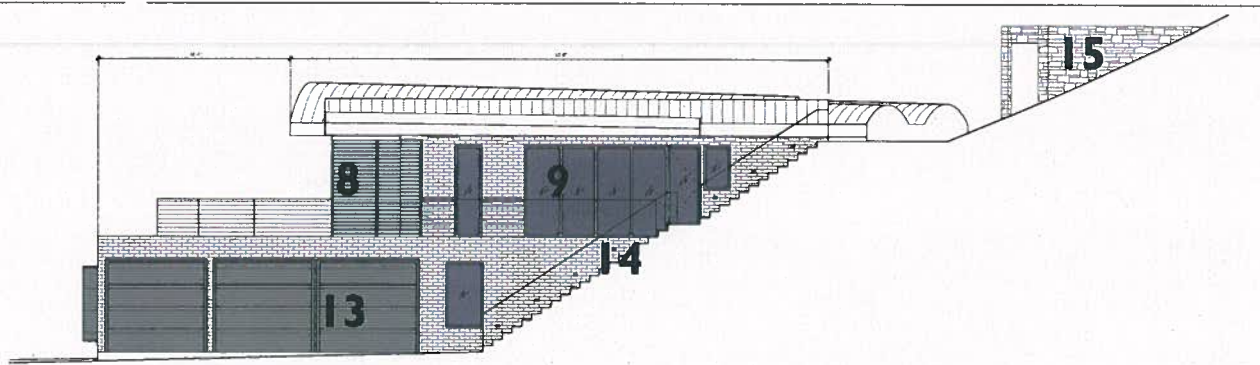

② EAST ELEVATION
1/4\"/>

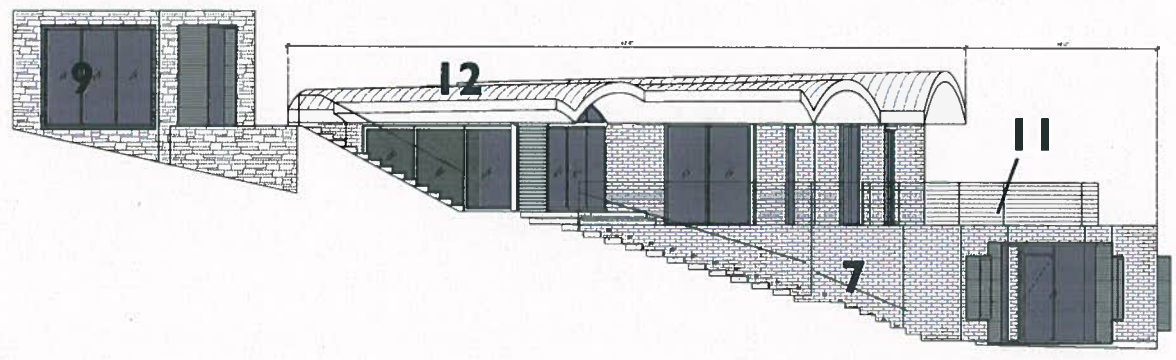

③ WEST ELEVATION
1/4\"/>

MATERIALS & FEATURES

1. Natural Chip Seal Paving
2. Concrete Pavers in Gravel
3. Stone Wall with Cobble Blanket
4. Stone Wall and Stair
5. Gravel Stair with Steel Edging
6. Reflection Pool
7. Rustic Red Brick
- 8 Wood Bris Soleil
9. Satin Grey Window/Sliding Door Frames
- 10 . Slatted Teak Window Projections
11. Metal Guardrail
12. Standing Seam Roof
- 13 . Dark Bronze Garage Door
14. Concrete Stair
15. Stone Cladding

2 8 4 3 9 F O O T H I L L D R I V E

f4NORTH

78 N. PARKWAY AVE. SUITE C
LOS ANGELES, CA 90048
WWW.F4NORTH.COM

28439 FOOTHILL DRIVE
AGOURA HILLS, CA 91 301
C.U.P. REVISIONS RESUBMIT
17 JULY 2017



01 VICINITY MAP
N.T.S.

AREA CALCULATIONS

| | | % of Lot | | | |
|--|-----------|-----------|-------|--|---|
| Lot Area | 63,378 SF | | | Permitted Dedicated Open Space % Maps 26-28 | Minimum % to Remain Open Space 77.8% |
| Avg. Slope | 6% | | | Development Area | 32,887 SF |
| Minimum Allowable Coverage | 25% | 16,079 SF | 25% | Area Shaded | 79% |
| Proposed Floor Coverage | 23.2% | 14,784 SF | 23.2% | 77.6% Open Slopes (Min) | 17,463 SF |
| Footprint of Structures | 4,428 SF | 6.9% | | Footprint of Structures | 4,428 SF |
| Impervious Area (Not Paved) | 10,361 SF | 16.3% | | 27.2% Wet Court Basin (Min) | 5,264 SF |
| Surface Area (Permeable & Total Underdeveloped Area) | 12,483 SF | 19.7% | | | |
| Proposed Floor Area | 3,877 SF | 6.1% | | | |
| Floor Area Level 1 | 1,828 SF | | | | |
| Floor Area Level 2 | 2,114 SF | | | | |
| Accessory Building | 236 SF | | | | |
| 3 Car Garage | 627 SF | | | | |
| Basement Storage | 86 SF | | | | |
| Recommended Floor Area | 3,488 SF | 5.5% | | | |
| Development Area | 22,507 SF | | | | |
| Avg. Slope | 36% | | | | |
| Over 30:051 | 2,288 SF | | | | |
| 30:051-45:051 | 168 SF | | | | |
| 45:051-75:051 | 4,100 SF | | | | |
| Slope Factor | 0.84 | | | | |

PROPERTY LEGAL DESCRIPTION

THE SOUTHERLY 302 FEET OF LOTS 3 AND A BLOCK 7 OF TRACT NO. 1851, MEASURED AT RIGHT ANGLES TO THE MOST SOUTHERLY LINES OF SAID LOTS, IN THE CITY OF AGOURA HILLS, COUNTY OF LOS ANGELES, STATE OF CALIFORNIA AS PER MAP RECORDED IN BOOK 104 PAGES 79 TO 90 INCLUSIVE OF MAPS IN THE OFFICE OF THE COUNTY RECORDER OF SAID COUNTY.

APN # 2055-019-037

PROJECT INFORMATION

ZONING: R1-D1-EQ
LOT AREA: 43.12 AC OR .99 ACRES
DEVELOPMENT AREA: 60,909 SQ. FEET OR 1.40 ACRES

| | REQUIRED | ALLOWED | PROPOSED |
|----------------------------------|------------|------------|------------|
| SMALL FAMILY RESIDENCE | | | 1,277 SF |
| LEVEL | | | 3,314 SF |
| ACCESSORY BUILDING | | | 236 SF |
| 3 CAR GARAGE | | | 627 SF |
| BASEMENT STORAGE | | | 86 SF |
| PROP. STRUCTURE | | | |
| PROP. STRUCTURE | 25' 0" MIN | 25' 0" MIN | 46' 0" MIN |
| BACK SETBACK | 12' 0" MIN | 12' 0" MIN | 12' 0" MIN |
| EAST SIDE YARD SETBACK | 12' 0" MIN | 12' 0" MIN | 12' 0" MIN |
| WEST SIDE YARD SETBACK | 12' 0" MIN | 12' 0" MIN | 12' 0" MIN |
| REAR SETBACK | 12' 0" MIN | 12' 0" MIN | 12' 0" MIN |
| ACCESSORY STRUCTURE | | | |
| FRONT SETBACK | 25' 0" MIN | 25' 0" MIN | 25' 0" MIN |
| BACK SETBACK | 25' 0" MIN | 25' 0" MIN | 25' 0" MIN |
| EAST SIDE YARD SETBACK | 12' 0" MIN | 12' 0" MIN | 12' 0" MIN |
| WEST SIDE YARD SETBACK | 12' 0" MIN | 12' 0" MIN | 12' 0" MIN |
| HEIGHT | 12' 0" MAX | 12' 0" MAX | 12' 0" MAX |
| PARKING SPACES (REQUIRED) | 1 | 1 | 1 |
| ENG. SPACES (ALLOWED) | 1 | 1 | 1 |

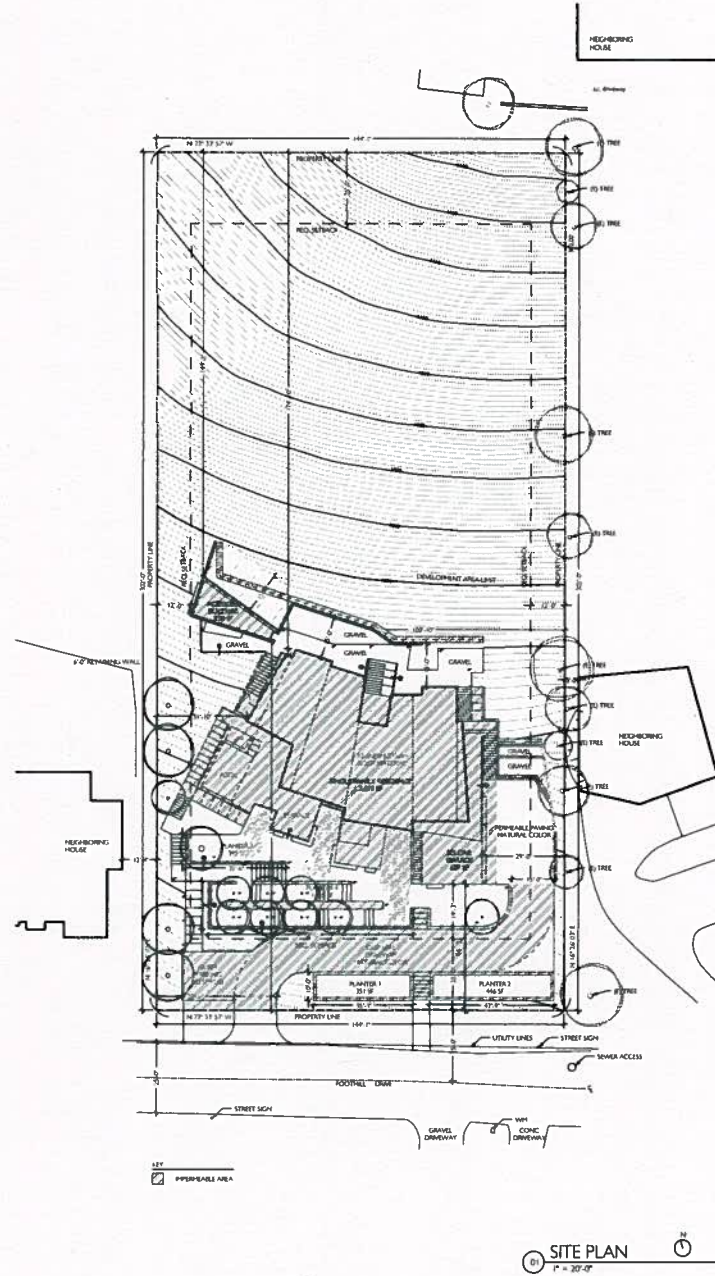

01 SITE PLAN
1" = 32'-0"

02 ARCHITECT
44 NORTH

719 N. FAIRWAY AVE., SUITE C
LOS ANGELES, CA 90048
310.441.1111

03 CLIENT

19201 AND LORRA AVE
39202 WESTRIDGE RD. #104
PUEBLO, CA 92468
310.441.1111

04 STAMP & COPYRIGHT



05 PREY PLAN



06 PROJECT

**28439
FOOTHILL
DRIVE**

07 PROJECT ADDRESS

28439 FOOTHILL DRIVE
AGOURA HILLS, CALIFORNIA 91301
APN 2055-019-037

08 PRELIMINARY

| NO. | DATE | DESCRIPTION |
|-----|------------|-------------|
| 1 | 10/20/2023 | PRELIMINARY |
| 2 | 11/15/2023 | REVISED |

09 SHEET TITLE

SITE PLAN

10 SHEET TITLE

A003

04 NORTH ARCHITECTURAL, LTD.

01 # ARCHITECT

LANDRUM

778 N. FAIRVIEW AVE. SUITE C
LOS ANGELES, CA 90006
TEL: 310.204.1111 FAX: 310.204.1111

02 # CLIENT

1001 AND LOMA ALAM
39500 W. 100TH ST. RENO, NV 89509
PAUL B. CA. 0003
1.1.10.10.10.10

03 # STAMP & COPYRIGHT



04 # SITE PLAN



05 # PROJECT

**28439
FOOTHILL
DRIVE**

06 # PROJECT ADDRESS

28439 FOOTHILL DRIVE
ACQUA VILLA, CA 91006-1101
APN: 2003-019-037

07 # REVISIONS

NO. DATE DESCRIPTION
01 11/20/08 100% DEVELOPMENT, SEE SHEET
02 11/20/08 100% DEVELOPMENT, SEE SHEET

08 # SHEET TITLE

**LEVEL I
PLAN**

09 # SHEET TITLE

A101

© LANDRUM ARCHITECTURE, LTD.

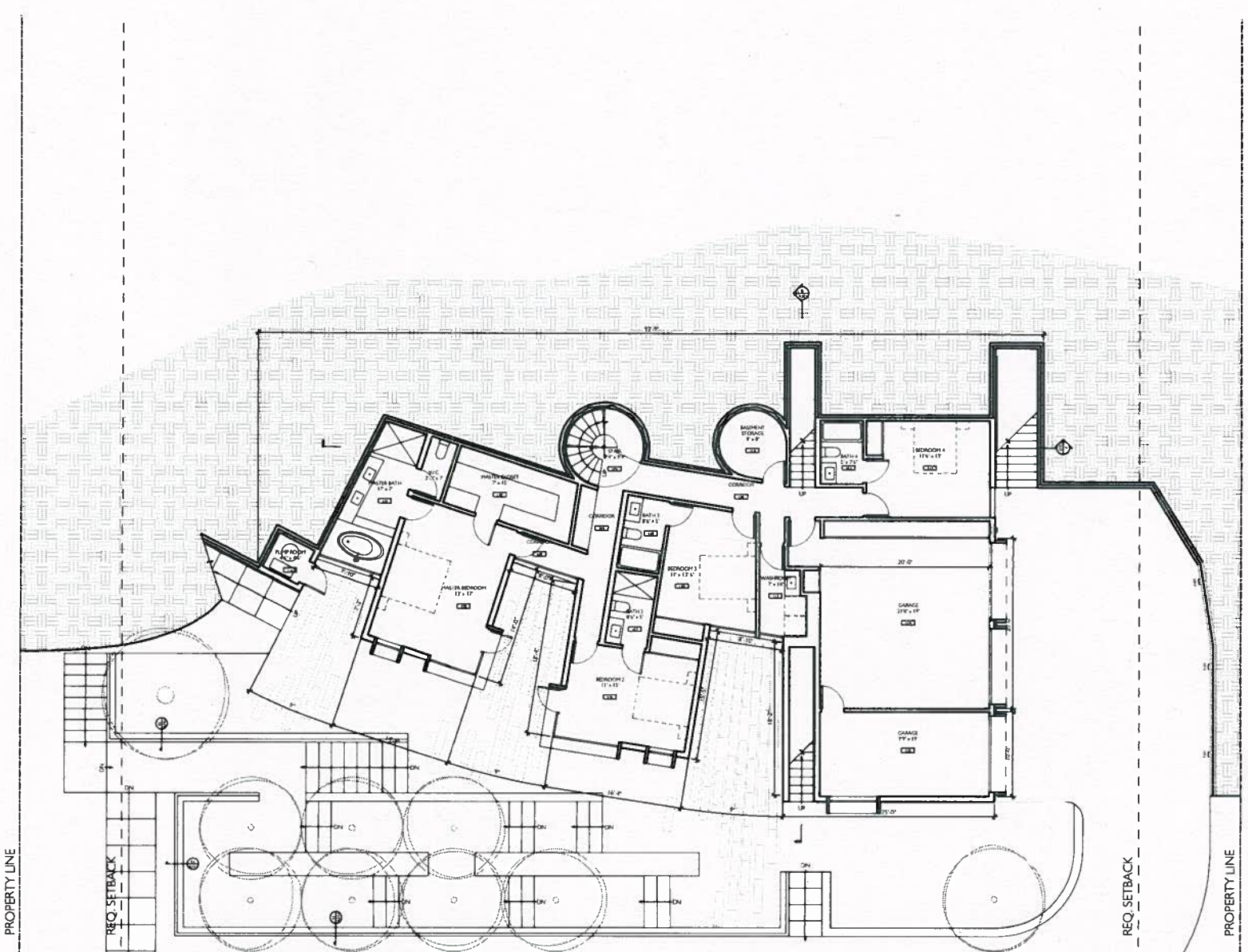

| UNITS | SYMBOL | DESCRIPTION | NOTES |
|-------|----------|-----------------------------|---|
| 1 | (Symbol) | RECESSED 2" DEEP WALL LIGHT | SEE ALSO REVISIONS WALL MOUNTED LIGHT OR RECESSED SPEAKER |
| 2 | (Symbol) | RECESSED 4" DEEP WALL LIGHT | SEE ALSO REVISIONS WALL MOUNTED LIGHT OR RECESSED SPEAKER |
| 3 | (Symbol) | RECESSED 6" DEEP WALL LIGHT | SEE ALSO REVISIONS WALL MOUNTED LIGHT OR RECESSED SPEAKER |
| 4 | (Symbol) | RECESSED 8" DEEP WALL LIGHT | SEE ALSO REVISIONS WALL MOUNTED LIGHT OR RECESSED SPEAKER |
| 5 | (Symbol) | 4" SQUARE LIGHT | SEE ALSO REVISIONS WALL MOUNTED LIGHT OR RECESSED SPEAKER |

PLAN - LEVEL I
3/16" = 1'-0"

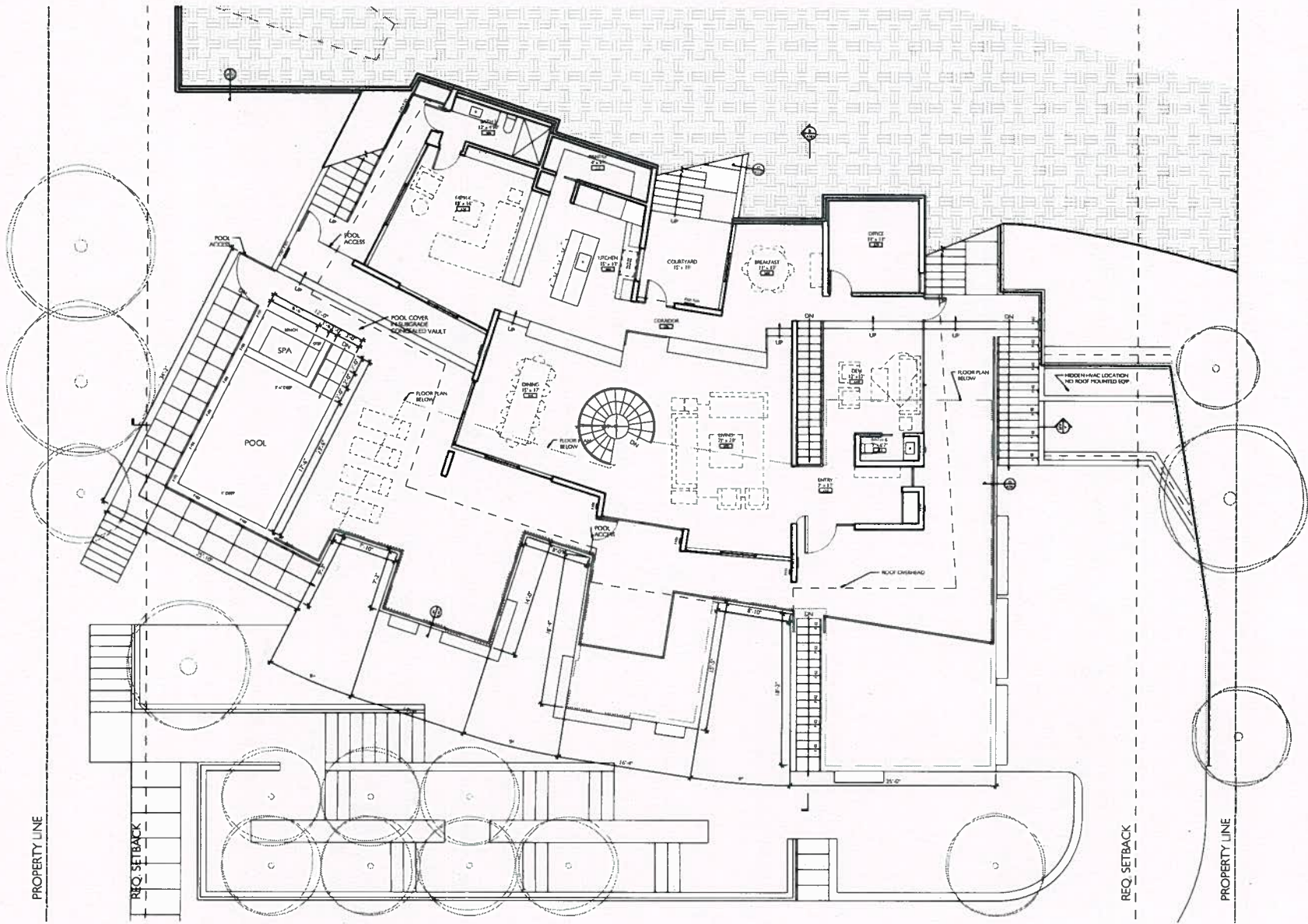

NOTES

1. LIGHTING & CEILING SCHEDULES

| SYMBOL | DESCRIPTION | NOTES |
|--------|------------------------|---|
| FL01 | LOW VOLTAGE WALL LIGHT | SEE LED LIGHTING SCHEDULE FOR APPROVED TYPE |
| FL02 | RECESSED TRAY LIGHT | SEE LED LIGHTING SCHEDULE FOR APPROVED TYPE |
| FL03 | LOW VOLTAGE WALL LIGHT | SEE LED LIGHTING SCHEDULE FOR APPROVED TYPE |
| FL04 | RECESSED TRAY LIGHT | SEE LED LIGHTING SCHEDULE FOR APPROVED TYPE |

01 ARCHITECT



718 N FAREWELL AVE. SUITE C
LOS ANGELES, CA 90048
TEL: 310.408.1111 FAX: 310.408.1112

02 CLIENT

ROSI AND LORNA ASAF
3929 FOOTHILL DRIVE, PALMDALE, CA 93550
TEL: 310.408.1111 FAX: 310.408.1112

03 STAMP & COPYRIGHT



04 SITE PLAN



05 PROJECT

28439
FOOTHILL
DRIVE

06 PROJECT ADDRESS

28439 FOOTHILL DRIVE
PALMDALE, CALIFORNIA 93550
APN: 3053-014-037

07 REVISIONS

| NO. | DATE | DESCRIPTION |
|-----|------------|----------------------|
| 1 | 10/15/2014 | ISSUE FOR PERMITTING |

08 SHEET TITLE

LEVEL 2
PLAN

09 SHEET TITLE

A102

PLAN - LEVEL 2
3/16" = 1'-0"

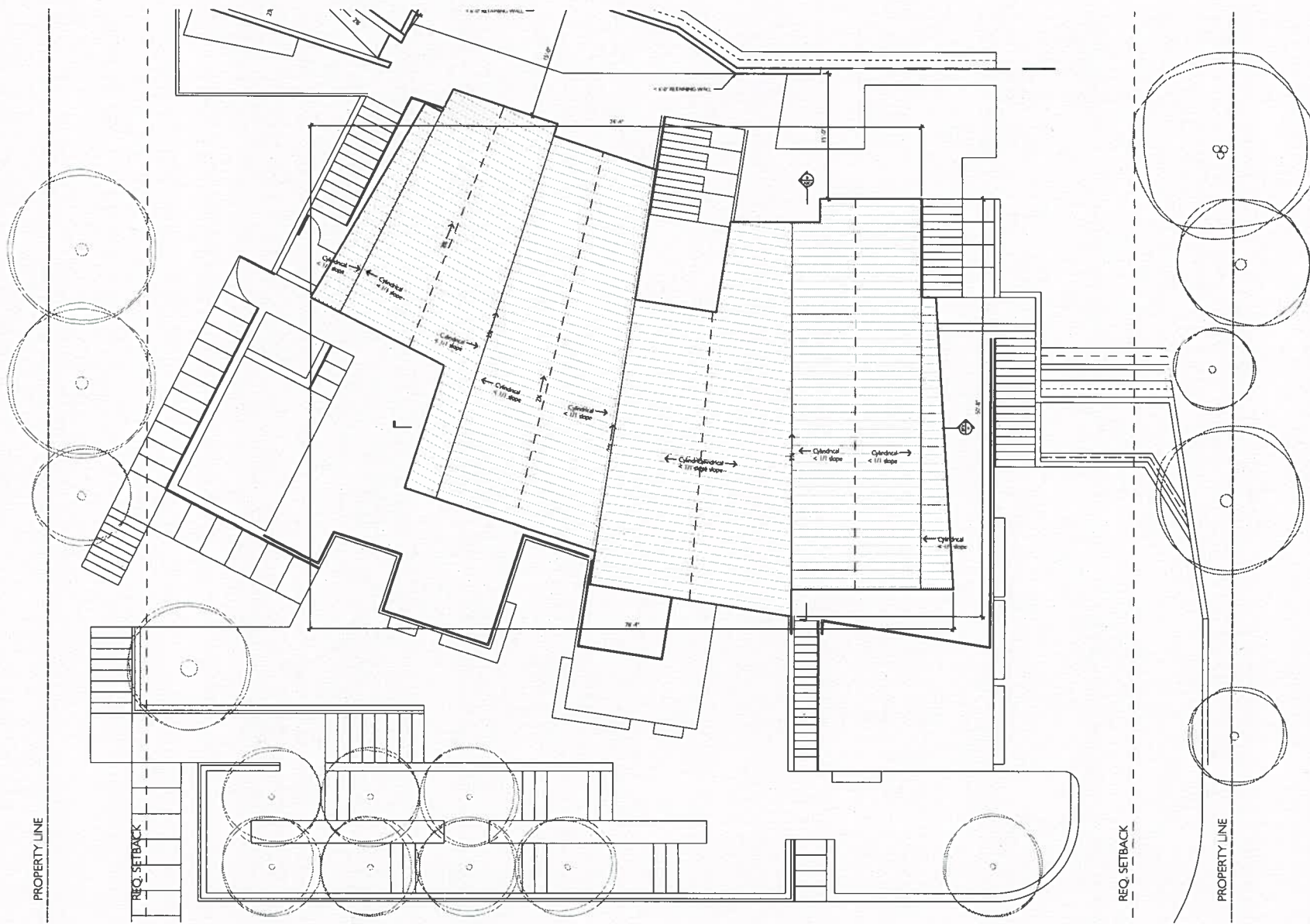

#1 ARCHITECT

66666666
 777 N FARRAGUT AVE, SUITE C
 LOS ANGELES, CA 90048
 T 310-777-7777 F 310-555-5555

#2 CLIENT

JOHN AND LUCIA ALAN
 7800 WEATHERCLOTH ROAD, NUMBER 42
 PALM BEACH, CA 90968
 T 310-456-7890

#3 STAMP & COPYRIGHT



#4 KEY PLAN



#5 PROJECT

**28439
 FOOTHILL
 DRIVE**

#6 PROJECT NUMBER

28439 FOOTHILL DRIVE
 AGCA PALM HILLS, CALIFORNIA 91301
 APR 2023-019-022

#7 REVISIONS

| NO. | DATE | DESCRIPTION |
|-----|------------|----------------------|
| 1 | 10/20/2023 | ISSUED FOR PERMITS |
| 2 | 11/15/2023 | REVISED FOR COMMENTS |

#8 SHEET TITLE

**ROOF
 PLAN**

#9 SHEET NUMBER

A103

© 66666666 ARCHITECTURE, LTD.

ROOF PLAN
 3/16" = 1'-0"

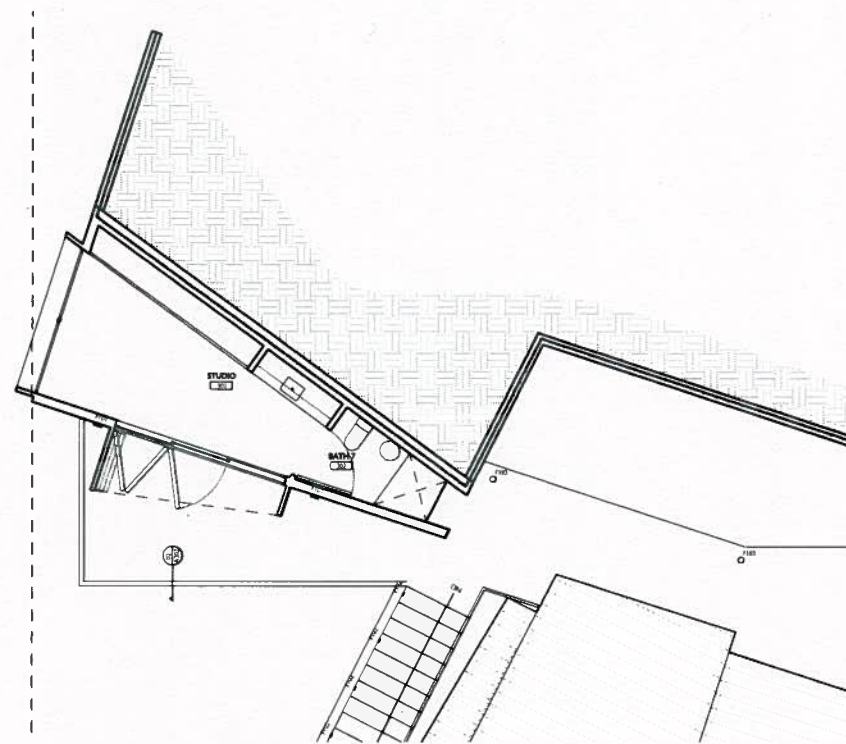
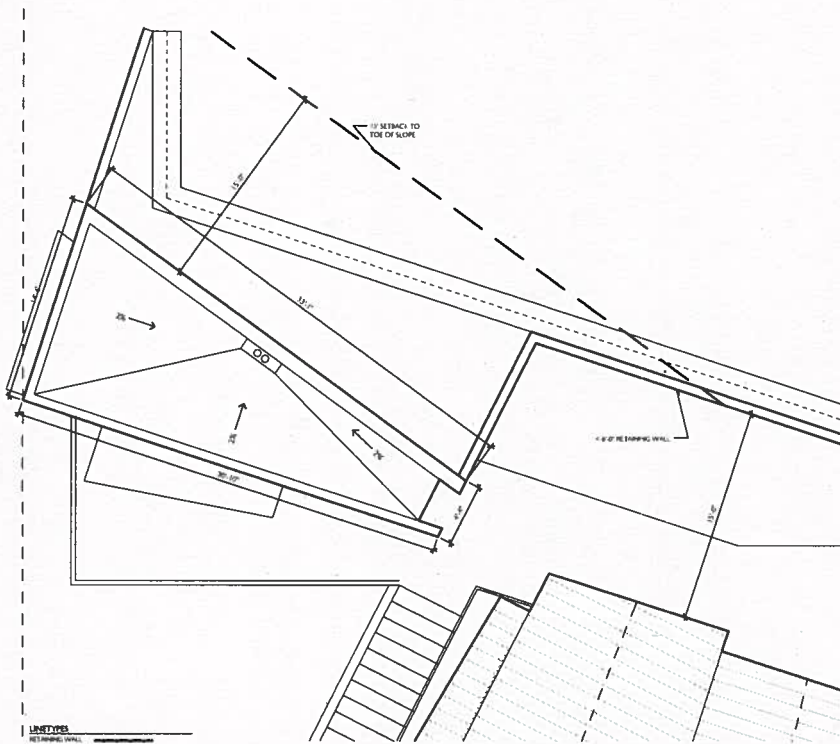

LINE TYPES
 RETAINING WALL

| LIGHTING & CEILING ELEMENT SCHEDULE | | | |
|-------------------------------------|--------|------------------------|--|
| ID | SYMBOL | NOTES | FIXTURE |
| F101 | LS | LOW MOUNTED WALL LIGHT | REGA LED SURFACE WALL WITH B-WELLS LIGHT OR APPROVED SIMILAR |
| F102 | SS | RECESSED STEP LIGHT | REGA LED RECESSED WALL OR APPROVED SIMILAR |
| F103 | CS | LOW MOUNTED WALL LIGHT | REGA LED WALL OR APPROVED SIMILAR |
| F104 | CS | IN-GRADE LIGHT | REGA LED IN-GRADE LUMINAIRE OR APPROVED SIMILAR |

01 ROOF PLAN - ACCESSORY BLDG.
 1/4" = 1'-0"

01 PLAN - ACCESSORY BLDG.
 1/4" = 1'-0"

DATE ARCHITECT

44 ARCHITECT

714 HARBOR AVENUE, SUITE C
 LOS ANGELES, CA 90044
 TEL: 213.756.1111 FAX: 213.756.1112

DATE CLIENT

MOH AND LOMA ALAM
 28439 FOOTHILL DRIVE, Foothill, CA 91024
 TEL: 951.261.0121

DATE STAMP & COPYRIGHT



DATE FIRST PLAN



DATE PROJECT

28439
 FOOTHILL
 DRIVE

DATE PROJECT ADDRESS

28439 FOOTHILL DRIVE
 FOOTHILL, CALIFORNIA 91024
 APR 2023 01A-01T

DATE REVISIONS

| NO. | DATE | DESCRIPTION |
|-----|----------|------------------|
| 01 | 04/20/23 | CONSTRUCTION SET |
| 02 | 04/20/23 | CONSTRUCTION SET |

DATE SHEET FILE

ACCESSORY BLDG.
 PLANS

DATE SHEET TITLE

A104

© 44 ARCHITECTURE LTD.

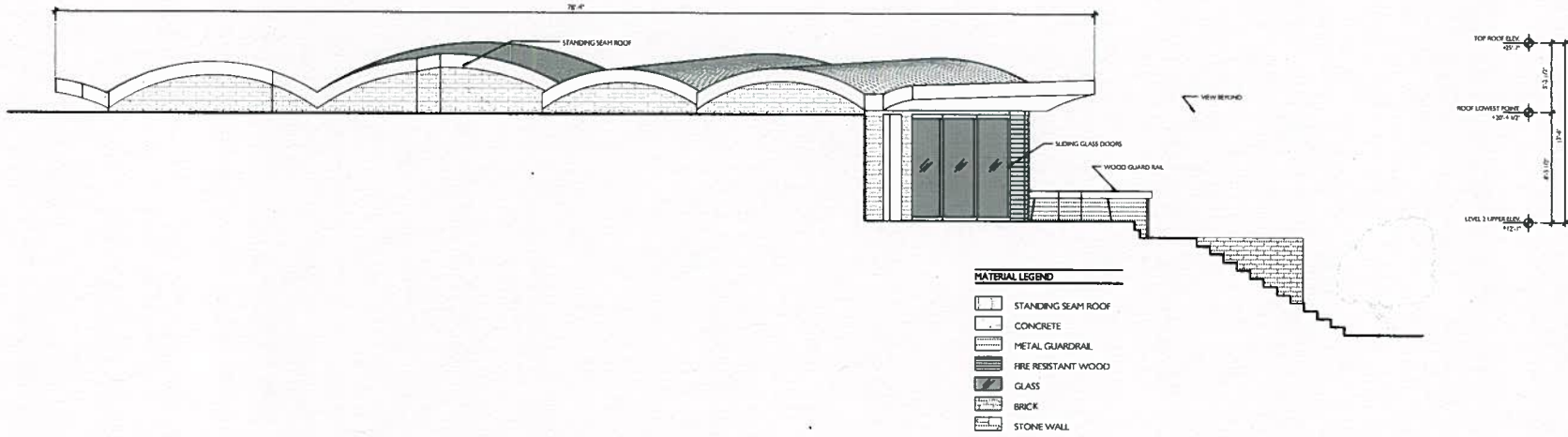

MATERIAL LEGEND

| | |
|--|---------------------|
| | STANDING SEAM ROOF |
| | CONCRETE |
| | METAL GUARDRAIL |
| | FIRE RESISTANT WOOD |
| | GLASS |
| | BRICK |
| | STONE WALL |

07 NORTH ELEVATION
1/4" = 1'-0"

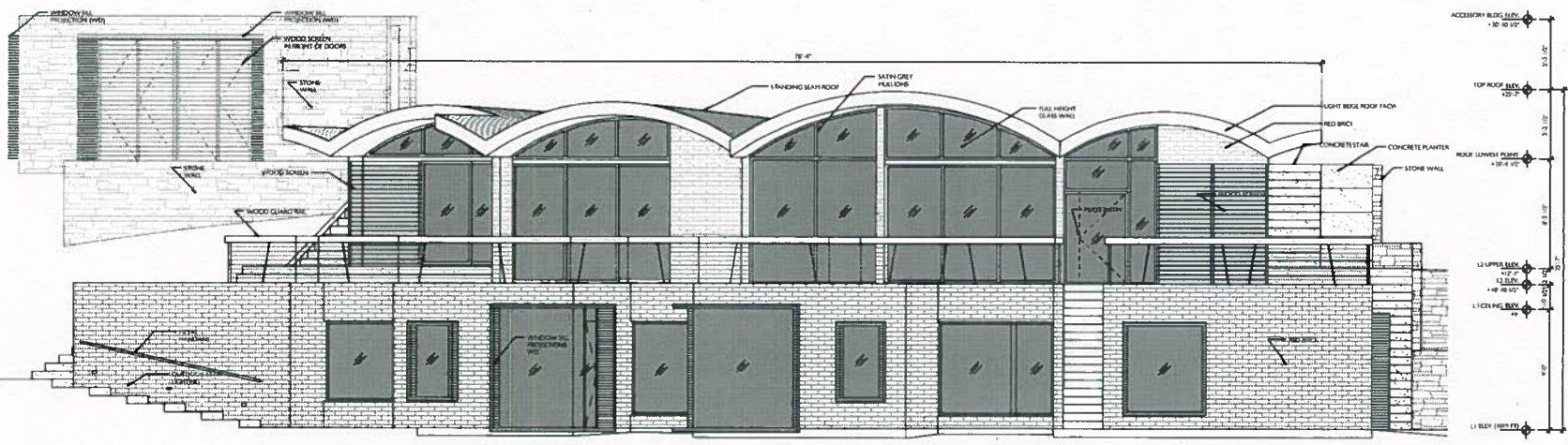

MATERIAL LEGEND

| | |
|--|---------------------|
| | STANDING SEAM ROOF |
| | CONCRETE |
| | METAL GUARDRAIL |
| | FIRE RESISTANT WOOD |
| | GLASS |
| | BRICK |
| | STONE WALL |

01 SOUTH ELEVATION
1/4" = 1'-0"

02 ARCHITECT

SPINORTH

78 N FARALL AVENUE, SUITE C
LOS ANGELES, CA 90048
T: 310-709-1111 F: 310-709-1118

03 CLIENT

ROTH AND LORNA ALAN
28439 FOOTHILL DRIVE, NUMBER 42
AGUIA HILLS, CALIFORNIA 91701

04 STAMP & COPYRIGHT

05 KEY PLAN

06 PROJECT

**28439
FOOTHILL
DRIVE**

07 PROJECT ADDRESS

28439 FOOTHILL DRIVE
AGUIA HILLS, CALIFORNIA 91701
APN 288-019-037

08 REVISIONS

| NO. | DATE | DESCRIPTION |
|-----|------------|-------------------|
| 01 | 04/11/2018 | CONCEPTUAL DESIGN |
| 02 | 04/11/2018 | CONCEPTUAL DESIGN |
| 03 | 04/11/2018 | CONCEPTUAL DESIGN |

09 SHEET TITLE

ELEVATIONS

09 SHEET TITLE

A201

© SPINORTH ARCHITECTURE, LTD.

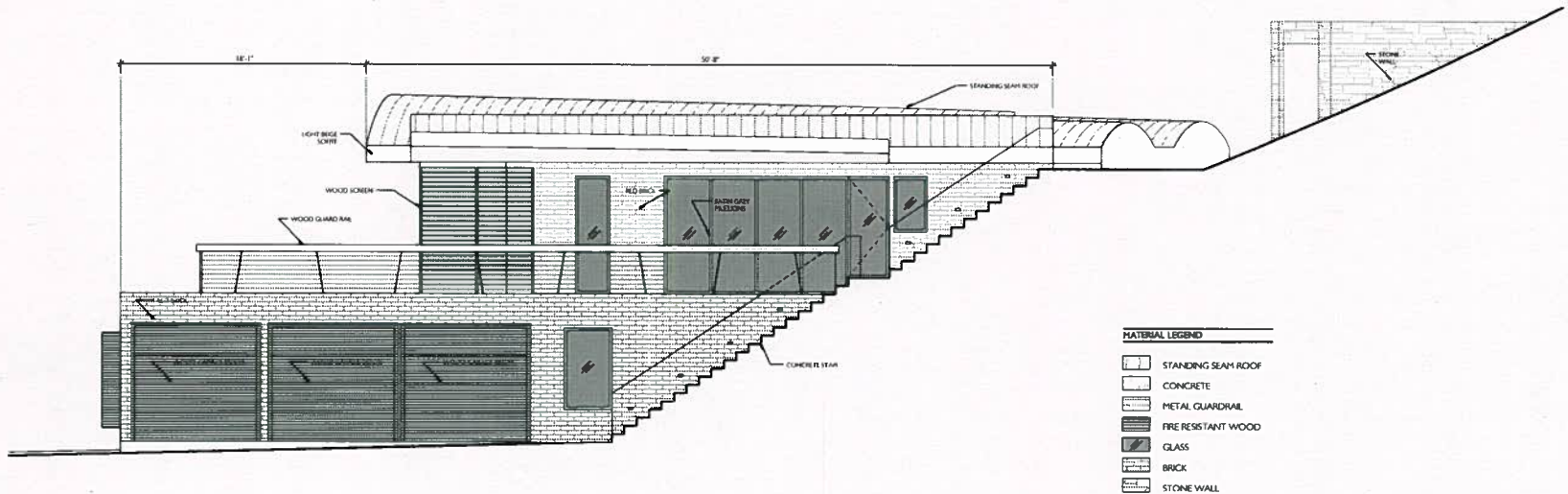

MATERIAL LEGEND

| | |
|--|---------------------|
| | STANDING SEAM ROOF |
| | CONCRETE |
| | METAL GUARDRAIL |
| | FIRE RESISTANT WOOD |
| | GLASS |
| | BRICK |
| | STONE WALL |

03 EAST ELEVATION
1/4" = 1'-0"

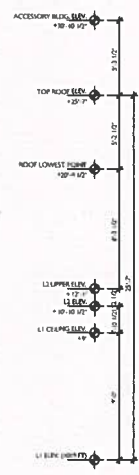

01 # ARCHITECT
SPINWORTH
775 N. TARRAFA AVE., SUITE C
LOS ANGELES, CA 90018
T 310 414 1111 F 310 411 5500

02 # CLIENT
PEDI AND LORNA ADAM
2700 W. HATHAWAY ROAD, NUMBER 40
PALM BEACH, CA 90703
T 310 475 5311

03 # STAMP & COPYRIGHT

04 # EAST PLAN

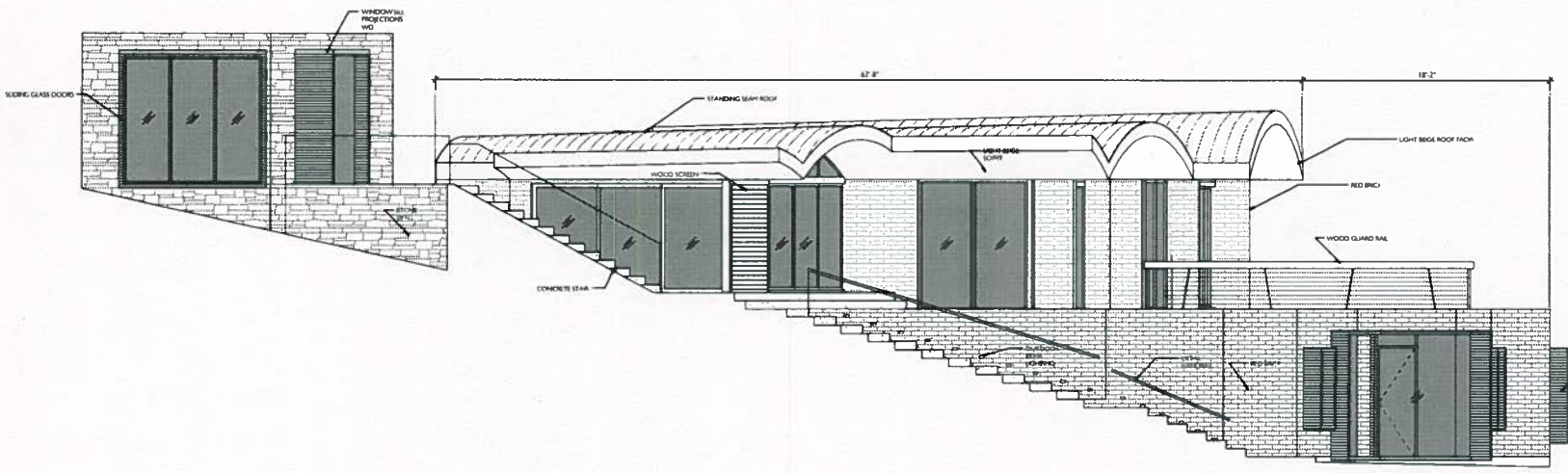

MATERIAL LEGEND

| | |
|--|---------------------|
| | STANDING SEAM ROOF |
| | CONCRETE |
| | METAL GUARDRAIL |
| | FIRE RESISTANT WOOD |
| | GLASS |
| | BRICK |
| | STONE WALL |

01 WEST ELEVATION
1/4" = 1'-0"

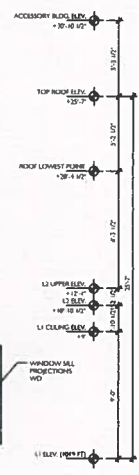

28439
FOOTHILL
DRIVE

05 # PROJECT ADDRESS
28439 FOOTHILL DRIVE
ACQUA HILLS, CALIFORNIA 91301
APN 383-014-031

07 # REVISIONS

| NO. | DATE | DESCRIPTION |
|-----|------------|-------------------------|
| 01 | 04/20/2016 | ISSUED FOR PERMITS |
| 02 | 05/10/2016 | ISSUED FOR CONSTRUCTION |

08 # SHEET TITLE

ELEVATIONS

09 # SHEET TITLE

A202

© SPINWORTH ARCHITECTURE, LTD.

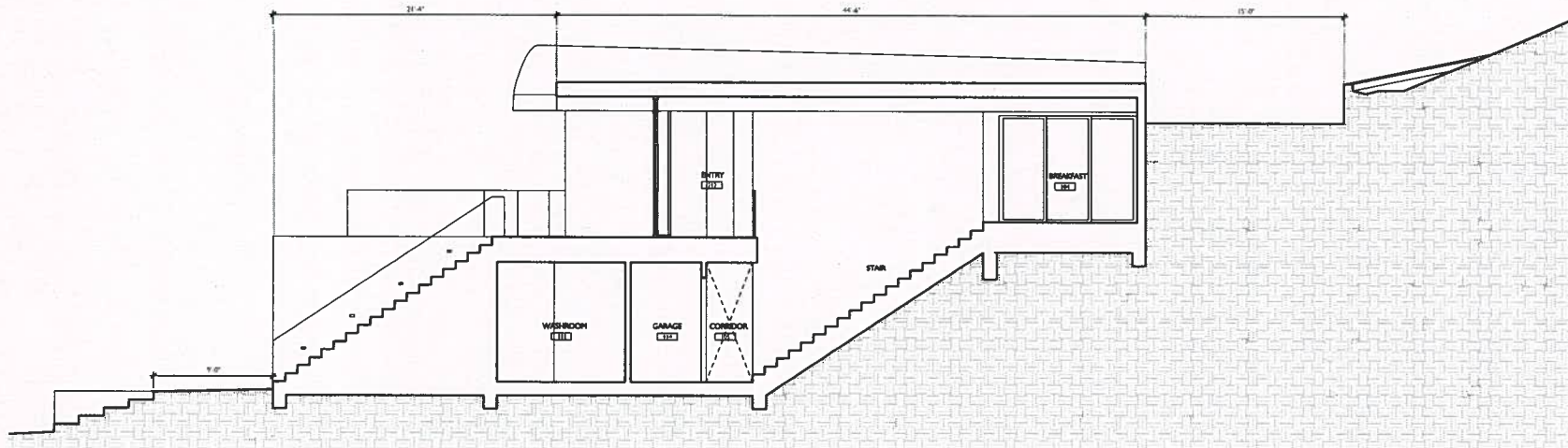

SECTION B
1/4" = 1'-0"

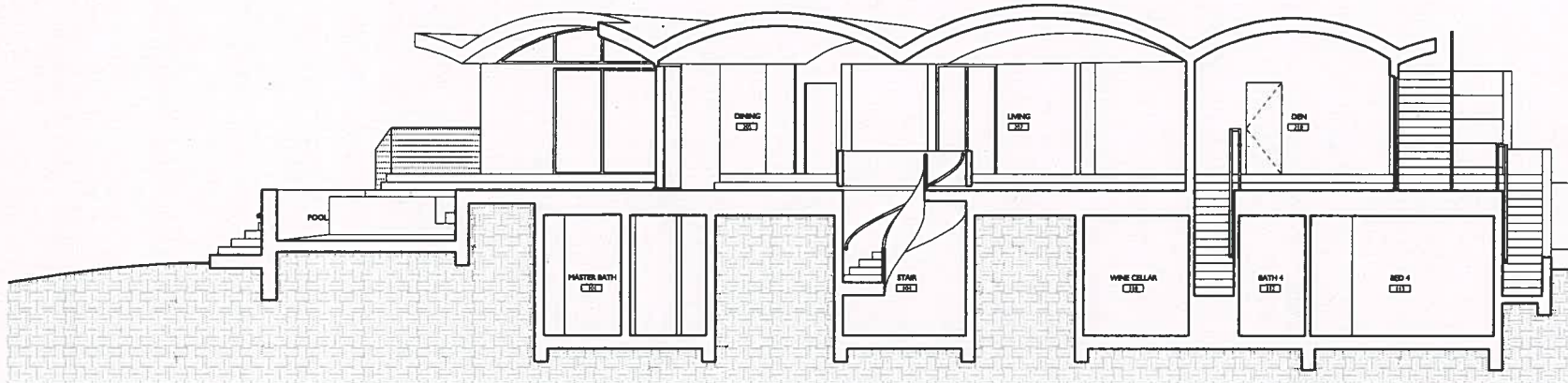

SECTION A
1/4" = 1'-0"

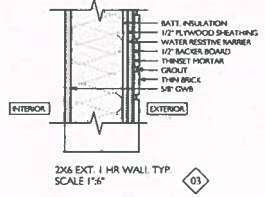
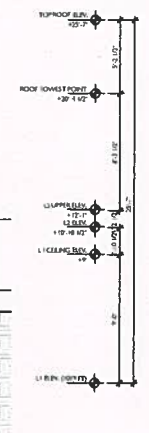

BY: ARCHITECT

GP ARCHITECT

719 N. KARLA AVENUE, SUITE C
LOS ANGELES, CA 90015
T 310-449-9111 F 310-831-8558

DATE: 08/14/10

PROJECT: 28439 FOOTHILL DRIVE
AGOURA HILLS, CALIFORNIA 91301
APN 280-014-017

BY: 08/14/10



DATE: 08/14/10



DATE: 08/14/10

28439
FOOTHILL
DRIVE

DATE: 08/14/10

28439 FOOTHILL DRIVE
AGOURA HILLS, CALIFORNIA 91301
APN 280-014-017

DATE: 08/14/10

DATE: 08/14/10
BY: 08/14/10
PROJECT: 28439 FOOTHILL DRIVE

DATE: 08/14/10

SECTIONS

DATE: 08/14/10

A301

GP ARCHITECTURE LTD.

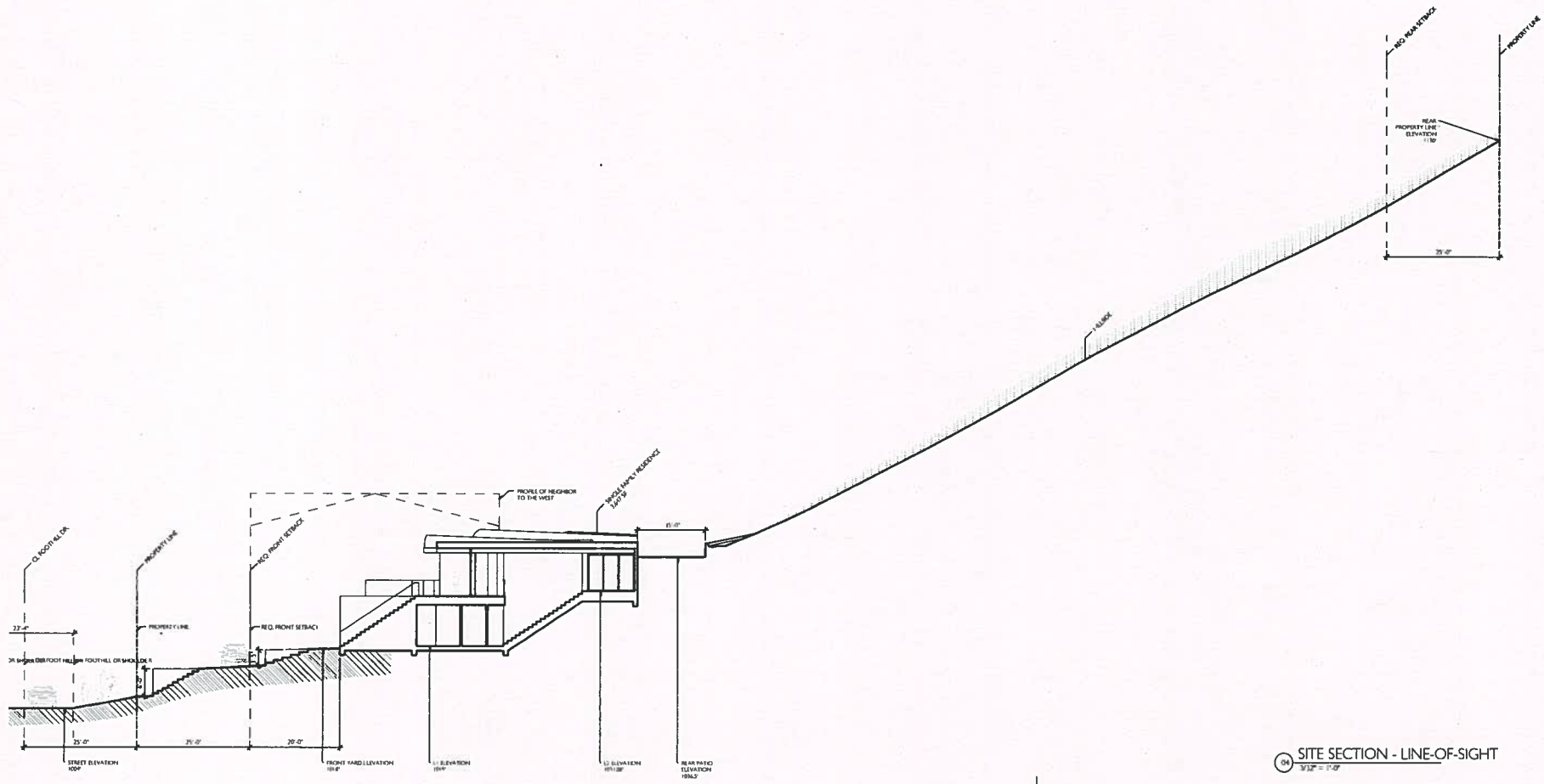

04 SITE SECTION - LINE-OF-SIGHT
3/16" = 1'-0"

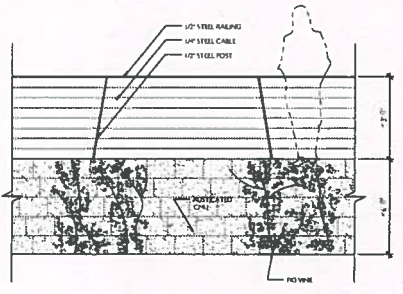

03 TYP. RETAINING WALL ELEVATION
1/2" = 1'-0"

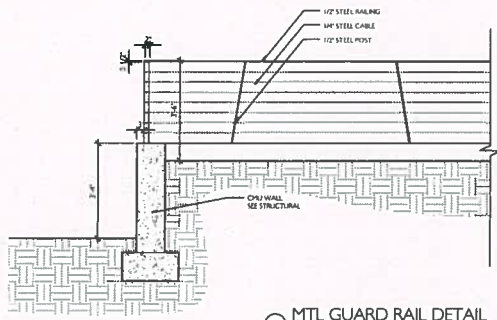

02 MTL GUARD RAIL DETAIL
1/2" = 1'-0"

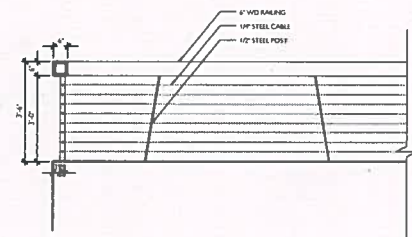

01 WD GUARD RAIL DETAIL
1/2" = 1'-0"

01 # ARCHITECT

6490RTH

174 N. FARLEY AVE. SUITE C
LOS ANGELES, CA 90006
TEL: 310.441.9171 WWW.6490RTH.COM

02 # CLIENT

POH AND LOKA ARCH
2700 HEATHERLYN ROAD, PALMDALE
PALMDALE, CA 91301
TEL: 805.357.1111

03 # STAMP & COPYRIGHT



04 # SHEET PLAN



05 # PROJECT

**28439
FOOTHILL
DRIVE**

06 # PROJECT ADDRESS

28439 FOOTHILL DRIVE
AGUA FRIAS, CALIFORNIA 91301
APN: 305-619-037

07 # REVISIONS

| NO. | DATE | DESCRIPTION |
|-----|------------|---------------------------|
| 01 | 02/28/2018 | COORDINATION WITH PERMITS |
| 02 | 03/01/2018 | FOR PERMITS SUBMITTAL |

08 # SHEET TITLE

**LINE OF SIGHT
SECTION**

09 # SHEET TITLE

A302



F101 - BEGA LED SURFACE WALL WITH SHIELDED LIGHT



F102 - BEGA LED RECESSED WALL



F103 - BEGA LED BOLLARD



F104 - BEGA LED IN-GRADE LUMINAIRE

| SYMBOL | DESCRIPTION | REMARKS |
|--------|--------------------------------------|--|
| F101 | LED SURFACE WALL WITH SHIELDED LIGHT | INSTALL LED SURFACE WALL WITH SHIELDED LIGHT AT APPROXIMATE SPACES |
| F102 | RECESSED WALL | INSTALL LED RECESSED WALL AT APPROXIMATE SPACES |
| F103 | LED BOLLARD | INSTALL LED BOLLARD AT APPROXIMATE SPACES |
| F104 | LED IN-GRADE LUMINAIRE | INSTALL LED IN-GRADE LUMINAIRE AT APPROXIMATE SPACES |

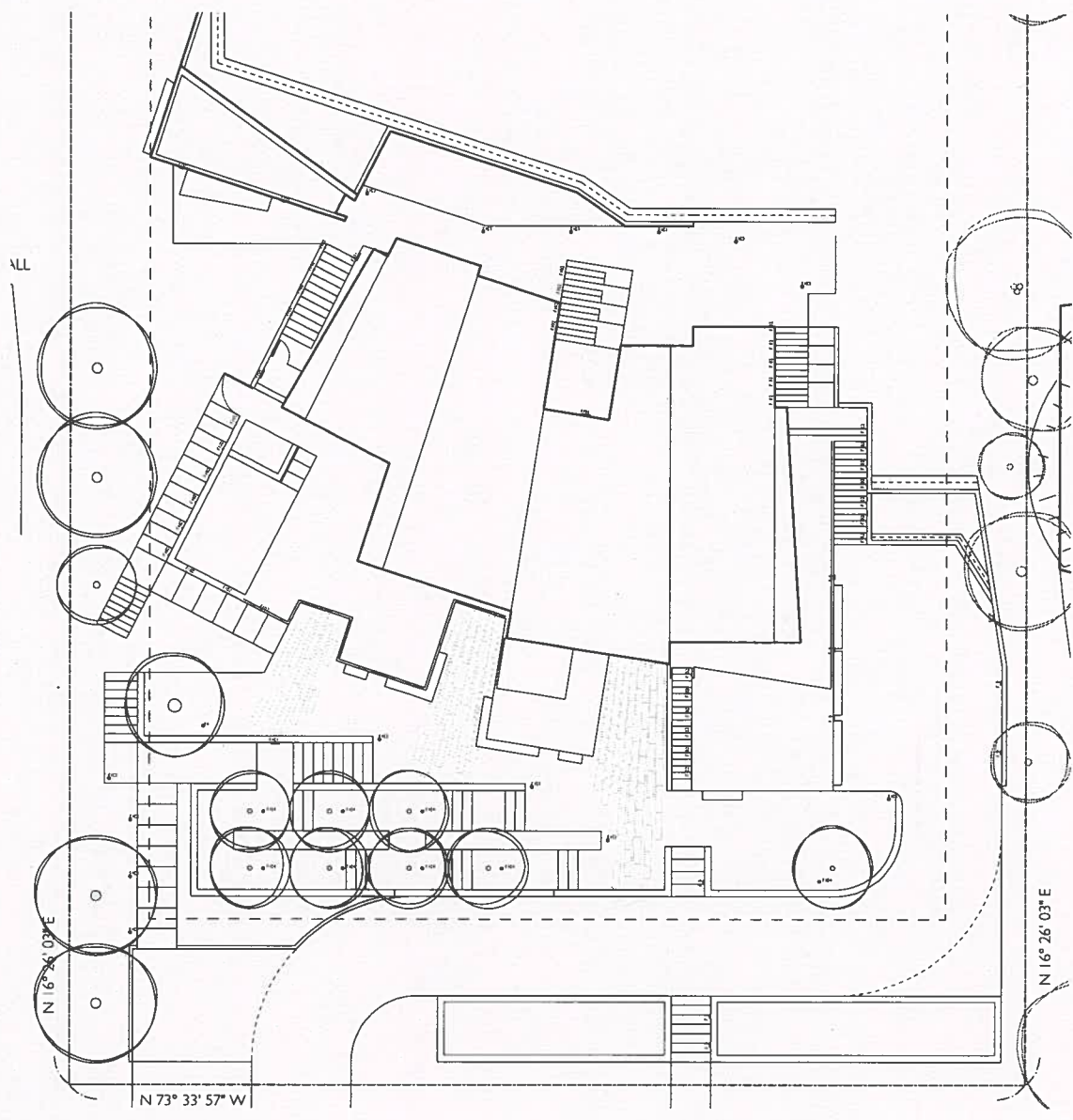

BY ARCHITECT



715 N FARMAY AVE, SUITE C
LOS ANGELES, CA 90068
T 310.491.9111 F 310.491.9112

BY CLIENT

HOTI AND UOHA ASH
2700 W HEATHERLY BOULEVARD, SUITE 102
PALMDALE, CA 93550
T 310.934.5151

BY STAMP & COPYRIGHT



BY SET PLAN



BY PROJECT

28439
FOOTHILL
DRIVE

BY PROJECT ADDRESS

28439 FOOTHILL DRIVE
AGAZOYA HILLS, CALIFORNIA 91024
APR 2025 04:10:27

BY REVISIONS

| NO. | DATE | DESCRIPTION |
|-----|------------|-----------------------|
| 1 | 10/11/2024 | ISSUED FOR PERMITTING |

BY SHEET TITLE

SITE PLAN
DIAGRAMS

BY SHEET TITLE

A402

64KORIN ARCHITECTURE, LTD.

11 SITE PLAN LIGHTING 12
1/8" = 1'-0"

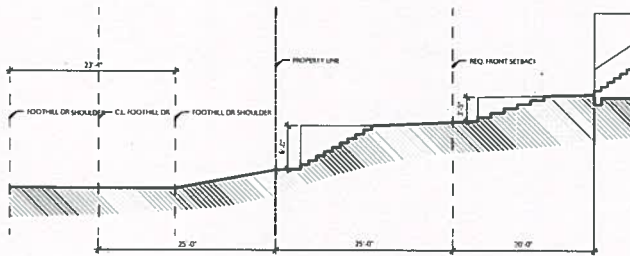

SECTION A
1/8" = 1'-0"

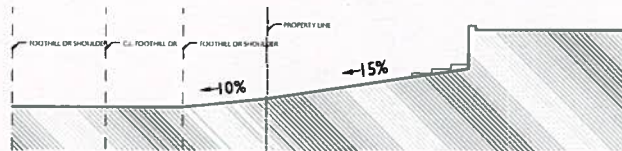

SECTION B
1/8" = 1'-0"

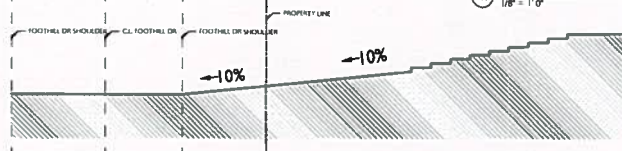

SECTION C
1/8" = 1'-0"

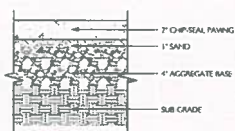

VEHICULAR ACCESS DETAIL (25 TONS)
1" = 8"

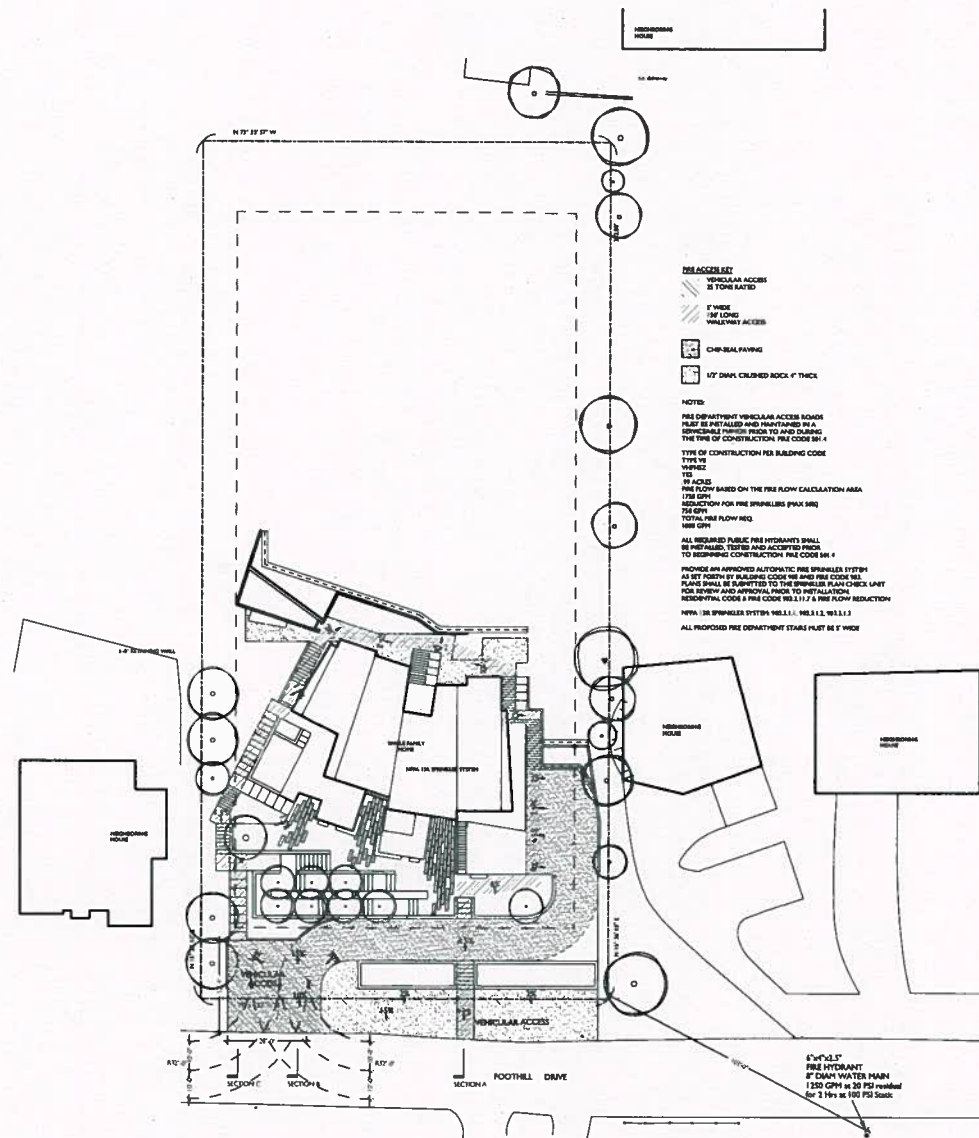

FIRE ACCESS KEY

- VEHICULAR ACCESS IS TONS RATED
- 1' WIDE 1/2" LONG VEHICULAR ACCESS
- CHIP SEAL PAVING
- 1/2" DIA. COLORED ROCK 4" THICK

NOTES:

FIRE DEPARTMENT VEHICULAR ACCESS ROADS MUST BE INSTALLED AND MAINTAINED PER A SPECIFIABLE PERMIT PRIOR TO AND DURING THE TIME OF CONSTRUCTION PER CODE 91.4 TYPE OF CONSTRUCTION PER BUILDING CODE TYPE VS VEHICLE

100 ACRES
FIRE FLOW BASED ON THE FIRE FLOW CALCULATION AREA
1750 GPM
SECTION FOR FIRE SPRINKLES (PUMP RING)
750 GPM
TOTAL FIRE FLOW REQ.
1800 GPM

ALL REQUIRED PUBLIC FIRE HYDRANTS SHALL BE INSTALLED, TESTED AND ACCEPTED PRIOR TO BEGINNING CONSTRUCTION PER CODE 91.4

PROVIDE AN APPROVED AUTOMATIC FIRE SPRINKLER SYSTEM AS SET FORTH BY BUILDING CODE AND FIRE CODE. ALL PLANS SHALL BE SUBMITTED TO THE SPRINKLER PLAN CHECK UNIT FOR REVIEW AND APPROVAL PRIOR TO INSTALLATION. RESIDENTIAL CODE & FIRE CODE 90.1.1.2 & FIRE FLOW REDUCTION.

NVA (IN SPRINKLER SYSTEM) SHALL BE 1/2, 1/2, 1/2, 1/2

ALL PROTECTED FIRE DEPARTMENT STAIRS MUST BE 6' WIDE

6" x 6" x 3.5" FIRE HYDRANT
8" DIAM. WATER MAIN
1250 GPM at 20 PSI residual
for 1.5 hrs at 100 PSI Static

ARCHITECT
44NORTH
714 N FAYAT AVE, SUITE C
LOS ANGELES, CA 90015
TEL: 310.464.9111 FAX: 310.464.9111

CLIENT
HOTI AND LICHA ASP
7500 WILSHIRE BLVD, SUITE 100
PALM BEACH, FL 33411-3511

DATE & COPYRIGHT
DATE: 04/20/07
DRAWN BY: [Signature]

PROJECT
28439
FOOTHILL
DRIVE

PROJECT ADDRESS
28439 FOOTHILL DRIVE
AGORA HILLS, CALIFORNIA 91001
APR 2007-019-007

REVISIONS
NO. DATE DESCRIPTION
1. 04/20/07 019-007-001
2. 04/20/07 019-007-002

SHEET TITLE
SITE PLAN
DIAGRAMS

SHEET NO.
01

A401

44NORTH ARCHITECTURE, LTD.

AGOURA HOUSE

28439 FOOTHILL DRIVE
IN THE CITY OF
AGOURA HILLS, CALIFORNIA

GRADING NOTES

- ALL GRADING SHALL BE IN ACCORDANCE WITH ARTICLE 6 OF THE AGOURA HILLS MUNICIPAL CODE.
- A PRE-CONSTRUCTION CONFERENCE OF ALL INTERESTED PARTIES SHALL BE HELD PRIOR TO ANY CONSTRUCTION. THIS SHALL INCLUDE ALL APPROPRIATE CITY STAFF.
- ALL EXPORT MATERIAL SHALL BE DELIVERED TO A SITE APPROVED BY THE CITY.
- ALL GEOLGIC AND SOIL RECOMMENDATIONS IMPOSED BY THE CONSULTANT OR CONTAINED IN THE CONSULTANT SOILS AND GEOLOGIC REPORT ARE TO BE COMPLIED WITH AND ARE HEREBY MADE AN INTEGRAL PART OF THE GRADING SPECIFICATIONS AND NOTES.
- ANY CHANGES IN THE WORK HEREON SHALL BE SUBJECT TO THE APPROVAL OF THE CITY ENGINEER.
- THE PERMITTEE SHALL EMPLOY A REGISTERED CIVIL ENGINEER TO PROVIDE CONSTANT ON-SITE GRADING SUPERVISION TO ASSURE COMPLIANCE WITH THE APPROVED PLANS AND A SOILS ENGINEER TO PROVIDE CONSTANT SOILS INSPECTION IN ACCORDANCE WITH THE AGOURA HILLS MUNICIPAL CODE.
- REPORTS REQUIRED:
 - ROUGH GRADING REPORT. PRIOR TO THE CONSTRUCTION OF ANY STRUCTURE, A ROUGH GRADING REPORT MUST BE SUBMITTED TO THE BUILDING OFFICIAL, STATING THAT ALL ROUGH GRADING HAS BEEN COMPLETED PER THE APPROVED GRADING PLANS.
 - FINAL GRADING REPORT. PRIOR TO THE FINALIZATION OF ANY GRADING PROJECT, A FINAL GRADING REPORT MUST BE SUBMITTED TO THE BUILDING OFFICIAL FOR APPROVAL. THE REPORT SHALL BE BY THE ENGINEER OF RECORD, STATING THAT ALL GRADING, LOT DRAINAGE AND DRAINAGE FACILITIES HAVE BEEN COMPLETED, AND THE SLOPE PLANTING AND IRRIGATION SYSTEMS HAVE BEEN INSTALLED IN CONFORMANCE WITH THE APPROVED PLANS AND REQUIREMENTS OF THE CITY OF AGOURA HILLS.
 - AN AS-BUILT SOILS REPORT SHALL BE SUBMITTED TO THE CITY FOR REVIEW. THIS REPORT, PREPARED BY THE GEOTECHNICAL CONSULTANT, MUST INCLUDE DOCUMENTATION OF ANY FOUNDATION INSPECTIONS, THE RESULTS OF ALL COMPACTION TESTS, AS WELL AS A MAP DETECTING THE LIMITS OF FILL, LOCATIONS OF ALL DENSITY TESTS, OUTLINE AND ELEVATIONS OF ALL RETAINING WALLS, KEYWAY LOCATIONS AND BOTTOM ELEVATIONS, LOCATIONS OF ALL SUBSIDIARIES AND FLOWLINE ELEVATIONS, AND LOCATION AND ELEVATION OF ALL RETAINING WALL BACKDRAINS AND OUTLETS. GEOLOGIC CONDITIONS EXPOSED DURING GRADING MUST BE DEPICTED ON AN AS-BUILT GEOLOGIC MAP.
- TESTS SHALL BE PERFORMED PRIOR TO POURING FOOTINGS AND SLABS TO DETERMINE THE EXPANSION INDEX OF THE SUPPORTING SOIL. IF THE EXPANSION INDEX IS GREATER THAN 1%, FOUNDATION AND SLAB PLANS SHOULD BE REVISED ACCORDINGLY.
- EXCAVATIONS SHALL BE MADE IN COMPLIANCE WITH CALIFORNIA REGULATIONS.
- A COPY OF THE GRADING PERMIT AND GRADING PLANS SHALL BE AVAILABLE ON-SITE AT ALL TIMES.
- ALL CONSTRUCTION ACTIVITY SHALL BE CONFINED TO THE HOURS OF 7:00 AM TO 7:00 PM, MONDAY THROUGH FRIDAY, UNLESS OTHERWISE APPROVED BY THE CITY ENGINEER. NO CONSTRUCTION SHALL BE PERMITTED ON GOVERNMENT-OBSERVED HOLIDAYS.

INSPECTION NOTES

THE PERMITTEE OR HIS AGENT SHALL NOTIFY THE BUILDING AND SAFETY DEPARTMENT AT LEAST TWO WORKING DAYS IN ADVANCE OF REQUIRED INSPECTIONS.

ABBREVIATIONS

- AC - ASPHALTIC CONCRETE
- C - CENTERLINE
- EP - EDGE OF PAVEMENT
- FP - FINISHED FLOOR
- FG - FINISHED GRADE
- FL - FLOWLINE
- FS - FINISH SURFACE
- LP - LOW POINT
- P.V. - PAVERS
- PL - PROPERTY LINE
- SMH - SEWER MANHOLE
- SB - SANITARY SEWER
- TC - TOP OF CURB
- TO - TOP OF GRADE
- TW - TOP OF WALL



PUBLIC UTILITIES / SERVICES

WATER: LAS VIRGENES MUNICIPAL WATER DISTRICT
4333 LAS VIRGENES ROAD
CALABAS, CA 91302
(916) 238-4116

ELECTRICAL: SOUTHERN CALIFORNIA Edison
2558 FOOTHILL DRIVE
THOUSAND OAKS, CA 91321
(805) 494-7916

TELEPHONE: SBC (PAC BELL)
1251 BAYVIEW STREET, #118
VAN NUYS, CA 91416
(916) 277-8888

OAS: SOUTHERN CALIFORNIA GAS
848 CARONDALE AVENUE
CHATSWORTH, CA 91313
(916) 791-3334

SEWER: LA COUNTY, DEPT. OF PUBLIC WORKS
SEWER MAINTENANCE DIVISION
1808 S. FREEMONT AVENUE, BLDG 58 EAST
ALHAMBRA, CA 91803
(626) 266-3338

CABLE: ADELPHA
2323 TELLER ROAD
NEWPORT PARK, CA 91262
(909) 774-8111

CABLE: CHARTER COMMUNICATIONS
3908 CROSSCREEK ROAD
MALIBU, CA 90263
(310) 495-9616

CALTRANS: CALTRANS
8950 REEBDA BOULEVARD
TUCUMAN, CA 91289
(909) 288-4428



LEGEND AND SYMBOLS

- PROPERTY LINE
- EXISTING GRADE CONTOUR
- PROPOSED GRADE CONTOUR
- SPOT ELEVATION
- PROPOSED SLOPE PER PLAN
- RETAINING WALL
- DAYLIGHT CUTFILL LINE
- DIRECTION OF FLOW (SLOPE)
- CONSTRUCTION NOTE NUMBER
- FLOWLINE

GENERAL NOTES

- ALL MATERIALS AND METHODS OF CONSTRUCTION SHALL CONFORM TO THE STANDARD SPECIFICATIONS FOR PUBLIC WORKS CONSTRUCTION (THE GREENBOOK), CURRENT EDITION, ALL SUPPLEMENTS THERETO, AND CITY OF AGOURA HILLS STANDARDS AS REQUIRED.
- ALL GRADING SHALL CONFORM TO REQUIREMENTS OF THE CALIFORNIA BUILDING CODE, LATEST EDITION AND THE CITY OF AGOURA HILLS GRADING CODE. IF CONTRADICTIONS ARISE BETWEEN VARIOUS CODES, THE MOST RESTRICTIVE STANDARDS APPLY.
- ALL GRADING WORK SHALL BE PERFORMED IN ACCORDANCE WITH THE REQUIREMENTS AND RECOMMENDATIONS CONTAINED IN THE GEOTECHNICAL REPORT DATED 10/27/2016.
- EXISTING TOPOGRAPHY SHOWN HEREON WAS TAKEN FROM A SURVEY DATED FEBRUARY 2016 BY AZMATH GROUP.
- THE CONTRACTOR SHALL ASSUME SOLE AND COMPLETE RESPONSIBILITY FOR THE JOB SITE CONDITIONS, INCLUDING SAFETY OF ALL PERSONS AND PROPERTY, DURING THE COURSE OF CONSTRUCTION OF THIS PROJECT. THIS REQUIREMENT SHALL APPLY CONTINUOUSLY, AND SHALL NOT BE LIMITED TO NORMAL WORKING HOURS.
- PRIOR TO COMMENCING CONSTRUCTION, THE CONTRACTOR SHALL VERIFY ALL JOB CONDITIONS FOR GRADING, DRAINAGE AND UNDERGROUND FACILITIES, INCLUDING THE LOCATION AND ELEVATION OF ALL SURFACE JOIN CONDITIONS, AND INCLUDING LOCATION AND ELEVATION OF EXISTING UNDERGROUND FACILITIES AT CROSSINGS WITH PROPOSED UNDERGROUND FACILITIES. IF CONDITIONS DIFFER FROM THOSE SHOWN ON THE PLANS, THE CONTRACTOR SHALL NOTIFY THE ENGINEER AND SHALL NOT BEGAN CONSTRUCTION UNTIL THE CHANGED CONDITIONS HAVE BEEN EVALUATED.
- ALL DRAWINGS ARE CONSIDERED TO BE A PART OF THE CONTRACT DOCUMENTS. THE CONTRACTOR SHALL BE RESPONSIBLE FOR THE REVIEW AND COORDINATION OF ALL DRAWINGS AND SPECIFICATIONS PRIOR TO THE START OF CONSTRUCTION. ANY DISCREPANCIES THAT OCCUR SHALL BE BROUGHT TO THE ATTENTION OF THE ARCHITECT/ENGINEER PRIOR TO START OF CONSTRUCTION SO THAT A CLARIFICATION CAN BE ISSUED. ANY WORK PERFORMED IN CONFLICT WITH THE CONTRACT DOCUMENTS OR ANY CODE REQUIREMENTS SHALL BE CONSIDERED BY THE CONTRACTOR AT THEIR OWN RISK AND AT NO EXPENSE TO THE OWNER OR ARCHITECT/ENGINEER.
- THE ENGINEER PREPARING THESE PLANS WILL NOT BE RESPONSIBLE FOR, OR LIABLE FOR, UNAUTHORIZED CHANGES TO OR USES OF THESE PLANS. ALL CHANGES TO THE PLANS MUST BE IN WRITING AND MUST BE APPROVED BY THE PREPARER OF THESE PLANS.
- NOTES AND DETAILS ON DRAWINGS SHALL TAKE PRECEDENCE OVER GENERAL NOTES AND TYPICAL DETAILS. WHERE NO DETAILS ARE GIVEN, CONSTRUCTION SHALL BE AS SHOWN FOR SIMILAR WORK.
- THE EXISTENCE, LOCATION AND CHARACTERISTICS OF UNDERGROUND UTILITY INFORMATION SHOWN ON THESE PLANS HAVE BEEN OBTAINED FROM A REVIEW OF AVAILABLE RECORD DATA. NO REPRESENTATION IS MADE AS TO THE ACCURACY OR COMPLETENESS OF SAID UTILITY INFORMATION. THE CONTRACTOR SHALL TAKE PRECAUTIONARY MEASURES TO PROTECT THE UTILITY LINES SHOWN AND ANY OTHER LINES NOT OF RECORD SHOWN ON THESE PLANS. CONTRACTOR SHALL VERIFY LOCATION.
- IF AT ANY TIME DURING GRADING OPERATIONS, ANY UNFAVORABLE GEOLOGICAL CONDITIONS ARE ENCOUNTERED, INCLUDING BUT NOT LIMITED TO THE UNCOVERING OF ARTICLES POTENTIALLY ARCHAEOLOGICAL IN NATURE, GRADING IN THAT AREA WILL STOP UNTIL APPROVED CORRECTIVE MEASURES ARE OBTAINED. CONTRACTOR WILL VERIFY LOCATION.
- THE PROPOSED GRADE IS THE FINAL GRADE AND NOT THE ROUGH GRADE. THE CONTRACTOR SHALL SUBTRACT THE THICKNESS OF THE PAVED SECTION AROUND LANDSCAPE PITCHES. SECTION TO ADJUST AT THE ROUGH GRADE ELEVATION.
- STRAIGHT GRADE SHALL BE MAINTAINED BETWEEN CONTOUR LINES AND SPOT ELEVATIONS UNLESS OTHERWISE SHOWN ON THE PLANS.
- ALL DEBRIS AND FOREIGN MATERIAL SHALL BE REMOVED FROM THE SITE AND DEPOSITED AT APPROVED DISPOSAL SITES. THE CONTRACTOR SHALL OBTAIN NECESSARY PERMITS FOR THE TRANSPORTATION OF MATERIAL TO AND FROM THE SITE.
- ALL FILL SOILS OR SOILS DISTURBED OR OVEREXCAVATED DURING CONSTRUCTION SHALL BE COMPACTED PER THE REQUIREMENTS OF THE SOILS REPORT AND THE SPECIFICATIONS.
- THE CONTRACTOR SHALL OBTAIN AN OSHA PERMIT FROM THE CALIFORNIA DIVISION OF INDUSTRIAL SAFETY PRIOR TO THE CONSTRUCTION OF TRENCHES OR EXCAVATIONS WHICH ARE FIVE FEET OR DEEPER.
- A LICENSED LAND SURVEYOR OR A REGISTERED CIVIL ENGINEER SHALL PERFORM CONSTRUCTION STAKING FOR IMPROVEMENTS SHOWN ON THESE PLANS.
- THE CONTRACTOR SHALL REPLACE ALL EXISTING IMPROVEMENTS DAMAGED DURING CONSTRUCTION TO MATCH EXISTING, INCLUDING PERMANENT TRENCH RESURFACING.

STORMWATER POLLUTION NOTES

- APPLICANT IS RESPONSIBLE FOR SUBMITTING A SITE-SPECIFIC, "STORM WATER POLLUTION PREVENTION PLAN" (SWPPP) AS OUTLINED IN THE MODEL PROGRAM FOR CONSTRUCTION MANAGEMENT BY THE COUNTY OF LOS ANGELES. THE SWPPP SHALL BE SIGNED AND STAMPED BY A STATE-LICENSED CIVIL ENGINEER. THE SWPPP SHALL OUTLINE "BEST MANAGEMENT PRACTICES" (BMP) PROCEDURES TO BE USED IN ORDER TO PREVENT THE TRANSPORT OF ON-SITE POLLUTANTS TO OFF-SITE LOCATIONS DURING AND AFTER CONSTRUCTION.
- A SITE-SPECIFIC, "WET-WEATHER EROSION-CONTROL PLAN" SHALL BE PREPARED IN CONJUNCTION WITH THE SWPPP, AND SHALL DESCRIBE BMP'S TO BE USED DURING CONSTRUCTION IN THE RAINY SEASON AND DETECT THEIR LOCATIONS RELATIVE TO THE SITE. THE PLAN MUST BE AVAILABLE ON-SITE BY OCTOBER 1ST, AND IMPLEMENTED FROM OCTOBER 1ST THROUGH APRIL 15TH.
- IT IS THE PROPERTY OWNER'S RESPONSIBILITY TO MAINTAIN ALL ON-SITE DRAINAGE STRUCTURES UNLESS OTHERWISE APPROVED BY THE CITY. CATCH BASIN FILTER INSERTS SHALL BE CLEANED OUT A MINIMUM OF THREE PER YEAR, ONCE BEFORE THE RAINY SEASON, AND AGAIN AFTER THE RAINY SEASON UNLESS OTHERWISE DIRECTED BY THE CITY ENGINEER.

OAK TREE NOTES

- APPLICANT MUST CONTACT CITY OAK TREE CONSULTANT, (916) 887-7326, TO OBTAIN PROJECT SPECIFIC "OAK TREE NOTES."

LEGAL DESCRIPTION

PORTIONS OF LOTS 5 AND 6 OF TRACT MAP 9451, SB 16479-88 IN THE COUNTY OF LOS ANGELES RECORDED'S OFFICE

BENCHMARK

Y 11293 (COUNTY OF LOS ANGELES MALIBU QUAD)
DPW 888 TAG IN SE CORNER OF DRIVEWAY TO HOUSE 8793 10TH PLACE W/ST OF CENTRALLINE 4.32' NORTH OF CENTRALLINE OF FOOTHILL DR.
ELEVATION = 877.156 (NAVD 88: 2005)

| INDEX OF DRAWINGS | |
|-------------------|--------------------------|
| SHEET NO. | DESCRIPTION |
| 1 | TITLE SHEET |
| 2 | EXISTING CONDITIONS PLAN |
| 3 | PRELIMINARY GRADING PLAN |
| 4 | EROSION CONTROL PLAN |

| ESTIMATED EARTHWORK QUANTITIES | | | |
|--------------------------------|----------|-------------------|--------|
| ESTIMATED CUT: | 648 CY | ESTIMATED EXPORT: | 0 CY |
| ESTIMATED FILL: | 825 CY | ESTIMATED IMPORT: | 280 CY |
| ESTIMATED OVER-EXCAVATION: | _____ CY | | |

| BENCHMARK: | | | |
|--------------|---------|------------|--------------|
| DESCRIPTION: | BM NO. | ELEVATION: | SURVEY DATE: |
| | Y 11293 | 877.156 | 2008 |

| RECORD DRAWING STATEMENT | | | |
|--|------|---------|-----------|
| I, _____, HEREBY CERTIFY, BASED ON MY FIELD OBSERVATION AND INFORMATION PROVIDED BY THE OWNER AND GENERAL CONTRACTOR, THAT THE WORK ON SHEET NOS. _____ THROUGH _____ MARKED AS "RECORD DRAWING" HAS BEEN CONSTRUCTED IN SUBSTANTIAL COMPLIANCE WITH THESE PLANS, SPECIFICATIONS, REVISIONS, CHANGE ORDERS, AND FIELD CHANGES. | | | |
| REGISTERED CIVIL ENGINEER | DATE | RCE NO. | EXP. DATE |

| SOILS APPROVAL | | | |
|---|------|---------|-----------|
| THIS PLAN HAS BEEN REVIEWED, AND IS IN COMPLIANCE WITH THE RECOMMENDATIONS IN OUR REPORT(S) DATED _____ | | | |
| REGISTERED GEOLOGIST | DATE | RCE NO. | EXP. DATE |
| REGISTERED GEOTECHNICAL ENGINEER | DATE | RCE NO. | EXP. DATE |

| OWNER | |
|-----------------|--|
| NAME: | MOTT & LUCIA ASP |
| ADDRESS: | 2950 HEATHERCROFT ROAD, # 42, MALIBU, CA 90265 |
| REPRESENTATIVE: | |
| TELEPHONE: | (310) 910-9919 |

| CIVIL ENGINEER | |
|-----------------|---|
| NAME: | LUCAS CORSBIE |
| ADDRESS: | 3331 OCEAN PARK BLVD, SUITE 100, SANTA MONICA, CA 90405 |
| REPRESENTATIVE: | LUCAS CORSBIE |
| TELEPHONE: | (827) 822-2189 |

| GEOTECHNICAL ENGINEER | |
|-----------------------|--|
| NAME: | FM CONSULTING |
| ADDRESS: | 30314 LEVINGTON DR. COSTA MESA, CA 92626 |
| REPRESENTATIVE: | FRANK WISGARD |
| TELEPHONE: | (949) 445-0188 |

| VICINITY MAP | | | |
|----------------------------------|------|---------|-----------|
| REGISTERED CIVIL ENGINEER | DATE | RCE NO. | EXP. DATE |
| REGISTERED GEOLOGIST | DATE | RCE NO. | EXP. DATE |
| REGISTERED GEOTECHNICAL ENGINEER | DATE | RCE NO. | EXP. DATE |

| REVISION # | SYMBOL | DESCRIPTION OF CHANGE | APPROVED | DATE |
|------------|--------|-----------------------|----------|------|
| | | | | |

| PREPARED BY: | | DATE | | CITY OF AGOURA HILLS APPROVAL | |
|---------------|------------------|----------|------|-------------------------------|---------------|
| LUCAS CORSBIE | PROJECT ENGINEER | 07/20/17 | DATE | RAMIRO ADEVA | CITY ENGINEER |

| REGISTERED CIVIL ENGINEER | | DATE | | RCE NO. | | EXP. DATE | |
|---------------------------|--|------|--|---------|--|-----------|--|
| | | | | | | | |

AGOURA HILLS

TITLE SHEET

SHEET 1 OF 5

EASEMENT NOTES:
 EASEMENT RECORDED IN BOOK 7498, PAGE 21 FOR THE PURPOSES OF ERECTING AND MAINTAINING TRENCH HOLES FOR LIGHT, POWER, TELEPHONE AND TELEGRAPH LINES, WATER PIPES AND OTHER PUBLIC UTILITIES (BLANKET IN NATURE).

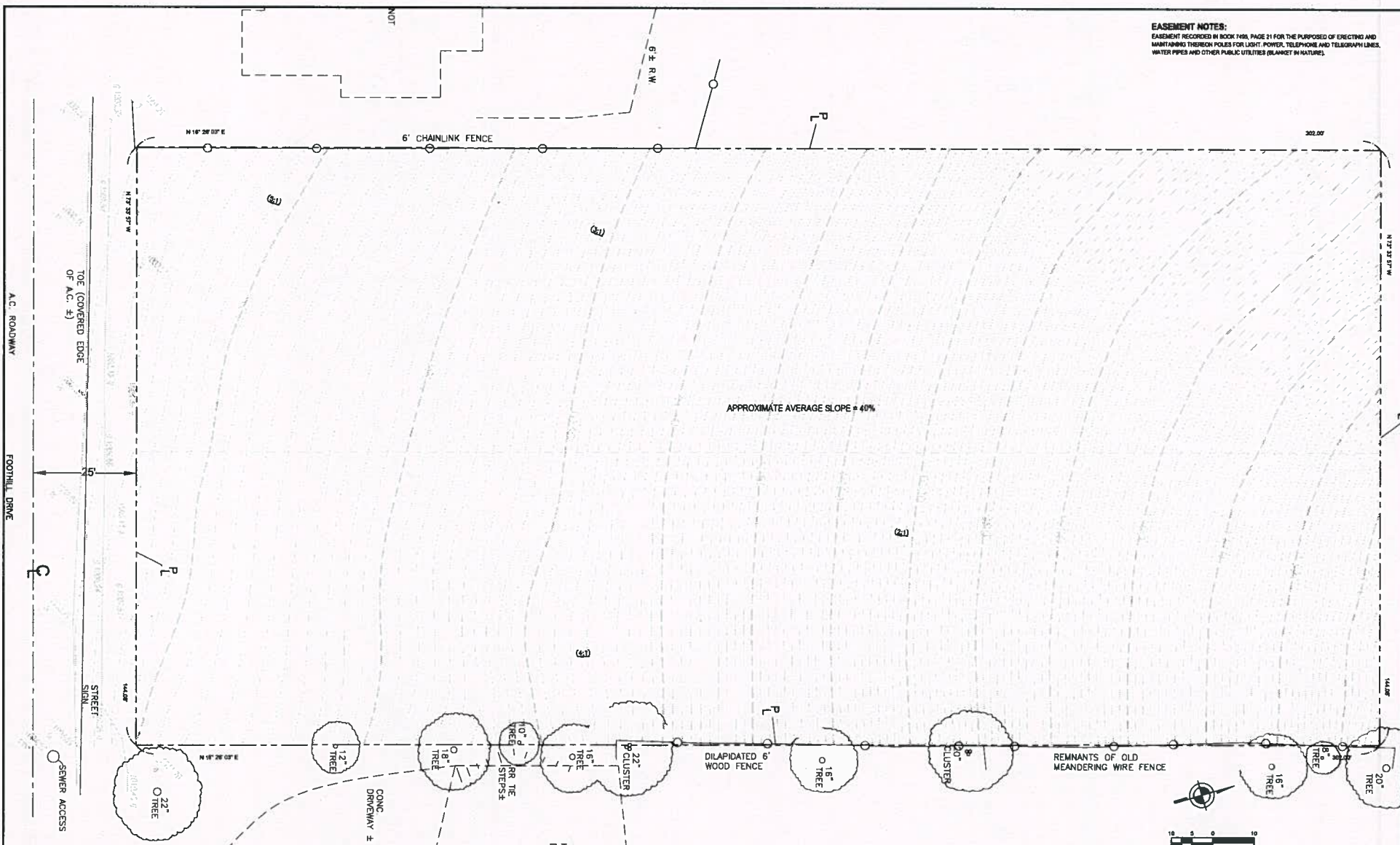

FOR REFERENCE ONLY

| | | | | | | | | | |
|--|--|--------|--|--------------------------|--|-------------------------------|--|---------------------------------------|--|
| REVISION # | | SYMBOL | | DESCRIPTION OF CHANGE | | APPROVED | | DATE | |
| | | | | | | | | | |
| PREPARED BY: LUCAS CORSBIE PROJECT ENGINEER | | | | DATE: 07/20/17 | | CITY OF AGOURA HILLS APPROVAL | | | |
| REVIEWED BY: | | | | DATE: | | DATE: | | DATE: | |
| | | | | | | RAMIRO ADEVA CITY ENGINEER | | 08865 RCE NO. 09/30/18 EXP DATE | |



EXISTING CONDITIONS

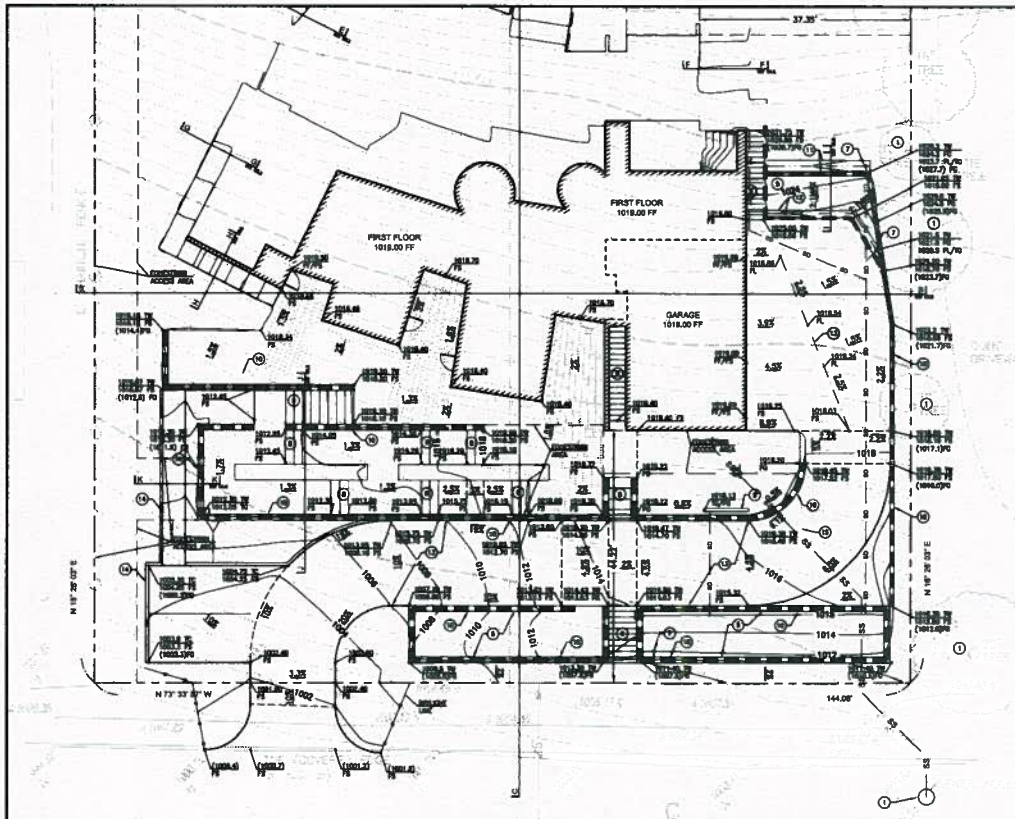

FIRST FLOOR

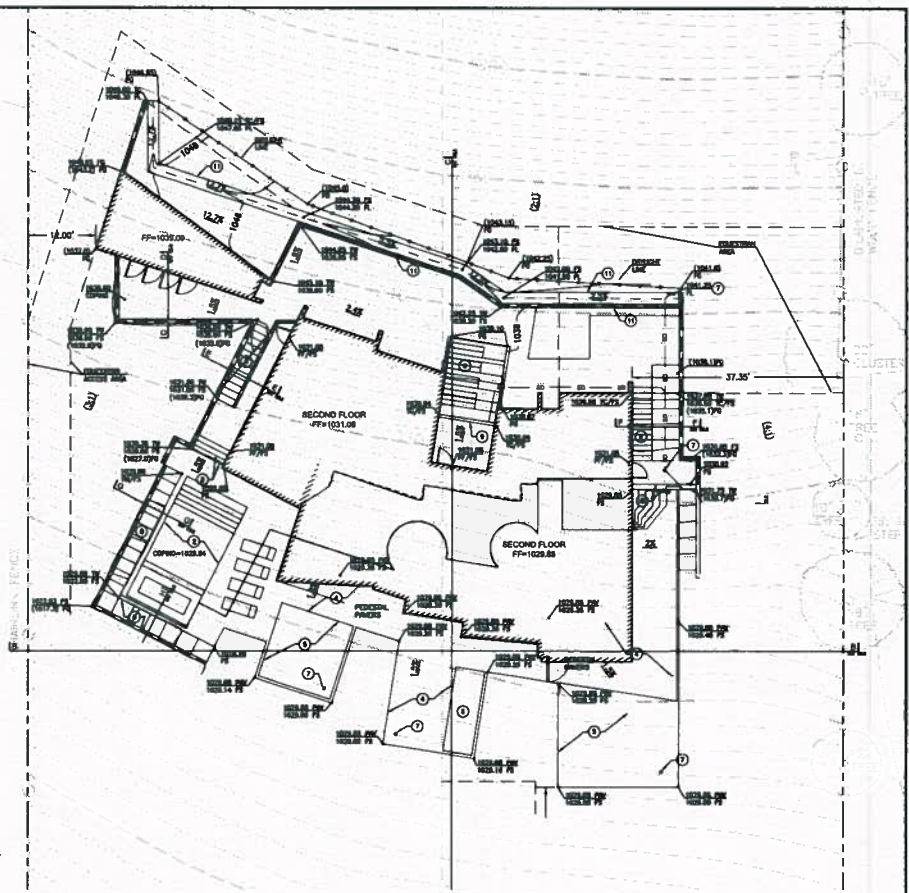

SECOND FLOOR

CONSTRUCTION NOTES

- 1 PROTECT IN PLACE.
- 2 INSTALL POOL PER POOL & SPA PLANS
- 3 INSTALL SPA PER POOL & SPA PLANS
- 4 INSTALL PEDESTAL PAVING PER ARCHITECTURAL PLANS
- 5 PLANTER AREA PER LANDSCAPE ARCHITECTURAL PLANS
- 6 GRAVEL PER ARCHITECTURAL PLANS
- 7 INSTALL DRAIN INLET
- 8 STAIR AND HANDRAIL PER ARCHITECTURAL PLANS.
- 9 INSTALL TRENCH DRAIN
- 10 INSTALL RETAINING WALL PER STRUCTURAL PLAN. SEE TYPICAL WALL DETAIL, SHEET 4
- 11 INSTALL 2' WIDE V-GUTTER
- 12 INSTALL 1' WIDE V-GUTTER
- 13 INSTALL CHIP SEAL DRIVEWAY
- 14 INSTALL CURB
- 15 INSTALL 4" SEWER LATERAL CONNECTION.



FOOTHILL DRIVE

| REVISION # | SYMBOL | DESCRIPTION OF CHANGE | APPROVED | DATE |
|------------|--------|-----------------------|----------|------|
| | | | | |
| | | | | |
| | | | | |

PREPARED BY:
LUCAS CORSINE
 PROJECT ENGINEER
 07/20/17
 DATE

REVIEWED BY: _____
 DATE _____

CITY OF AGOURA HILLS APPROVAL
RAMIRO ADEVA
 CITY ENGINEER
 DATE _____
 TRCE NO. _____
 0805
 08/03/18
 EXP DATE



PRELIMINARY GRADING PLAN



SHEET 3 OF 5

NOTE: ALL WALLS SHOWN HEREON COMPLY WITH AGOURA MUNICIPAL CODE. SITE RETAINING WALLS DESIGNED TO HAVE <6' EXPOSED FACE IN ALL CASES.

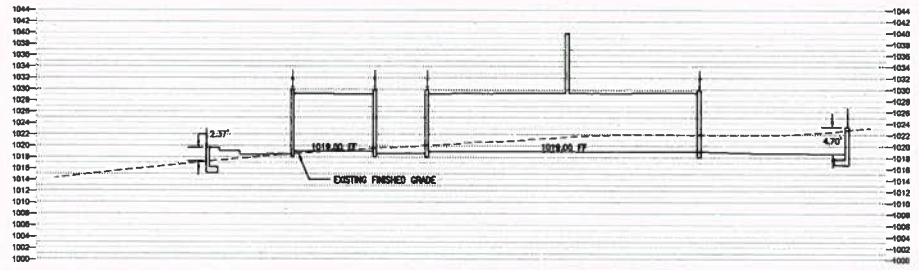

SECTION B-B
1" = 10'

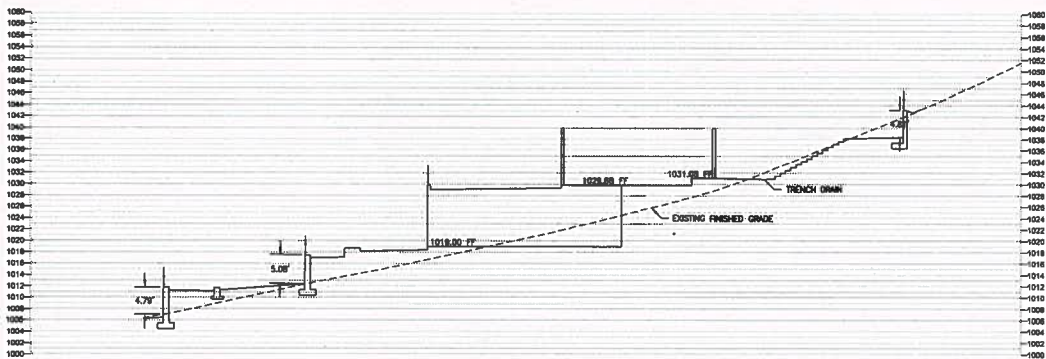

SECTION C-C
1" = 10'

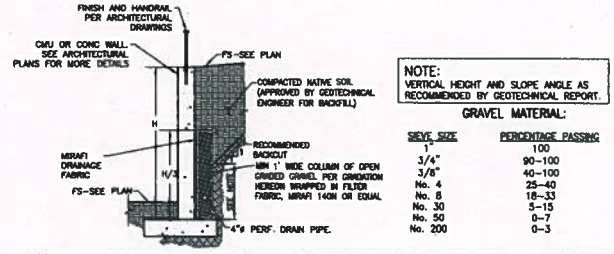

TYP. RET. WALL DRAINAGE DETAIL

NOTE: VERTICAL HEIGHT AND SLOPE ANGLE AS RECOMMENDED BY GEOTECHNICAL REPORT.

GRAVEL MATERIAL:

| SEIVE SIZE | PERCENTAGE PASSING |
|------------|--------------------|
| 100 | 100 |
| 3/4" | 90-100 |
| 3/8" | 40-100 |
| No. 4 | 25-40 |
| No. 8 | 18-33 |
| No. 30 | 5-15 |
| No. 50 | 0-7 |
| No. 200 | 0-3 |

SCALE: NTS

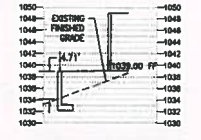

SECTION D-D
1" = 10'



SECTION E-E
1" = 10'

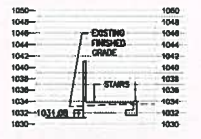

SECTION F-F
1" = 10'

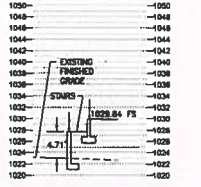

SECTION G-G
1" = 10'

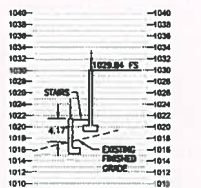

SECTION H-H
1" = 10'



SECTION I-I
1" = 10'

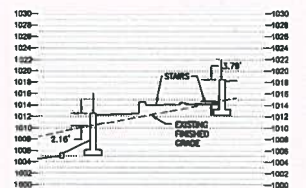

SECTION J-J
1" = 10'

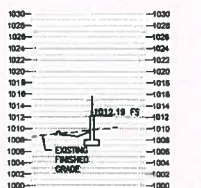

SECTION K-K
1" = 10'

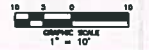

| | | | | | | | | | | | | | | | | | | | | |
|------------|--------|-----------------------|----------|--|------------------|-------------------------------|-------------------------------|------|--|------------------|--|----------------------|--|--------------|--|-------------------------------------|--|----------------------------|-------------------------------|--|
| | | | | PREPARED BY: LUCAS CORSSIE PROJECT ENGINEER | 07/20/17 DATE | CITY OF AGOURA HILLS APPROVAL | | | | 6895 RICE NO. | | 08/30/18 EXP DATE | | AGOURA HILLS | | PRELIMINARY GRADING SECTIONS | | SHEET 4 OF 5 | | |
| REVISION # | SYMBOL | DESCRIPTION OF CHANGE | APPROVED | DATE | REVIEWED BY | DATE | RAMIRO ADEVA CITY ENGINEER | DATE | | | | | | | | | | | CITY OF AGOURA HILLS DWG. NO. | |

GENERAL SEDIMENT AND EROSION CONTROL NOTES

1. IN CASE OF AN EMERGENCY, CALL THE AT _____
2. NON STORMWATER RUNOFF FROM EQUIPMENT AND VEHICLE WASHING AND ANY OTHER ACTIVITY SHALL BE CONTAINED AT THE PROJECT SITE.
3. A STORM-BY ORDER FOR EMERGENCY WORK SHALL BE AVAILABLE AT ALL TIMES DURING THE RAINY SEASON (OCTOBER 1 TO APRIL 15). NECESSARY MATERIALS SHALL BE AVAILABLE ON-SITE AND STOCKPILED AT CONVENIENT LOCATIONS TO FACILITATE RAPID CONSTRUCTION OF EMERGENCY DEVICES WHEN RAIN IS IMMINENT.
4. EROSION CONTROL DEVICES SHOWN ON THIS PLAN MAY BE REMOVED WHEN APPROVED BY THE BUILDING OFFICIAL IF THE GRADING OPERATION HAS PROCEEDED TO THE POINT WHERE THEY ARE NO LONGER REQUIRED.
5. GRADED AREAS ADJACENT TO HILL SLOPES LOCATED AT THE SITE PERIMETER MUST DRAIN AWAY FROM THE TOP OF SLOPE AS THE COMPLETION OF EACH WORKING DAY. ALL LOOSE SOILS AND DEBRIS THAT MAY CREATE A POTENTIAL HAZARD TO OFF-SITE PROPERTY SHALL BE STABILIZED OR REMOVED FROM THE SITE ON A DAILY BASIS.
6. ALL SILT AND DEBRIS SHALL BE REMOVED FROM ALL DEVICES WITHIN 24 HOURS AFTER EACH RAINSTORM AND BE DEPOSITED OFF PROPERTY.
7. A CURB SHALL BE POSSED ON THE SITE UNLESS THE DEPTH OF WATER IN ANY DEVICE EXCEEDS TWO FEET. THE CURB SHALL BE DRAINED OR PUMPED DRY WITHIN 24 HOURS AFTER EACH RAINSTORM. PUMPING AND DRAINING OF ALL DEVICES AND DRAINAGE DEVICES MUST COMPLY WITH THE APPROPRIATE SFP FOR DRAINAGING OPERATIONS.
8. THE PLACEMENT OF ADDITIONAL DEVICES TO REDUCE EROSION DAMAGE AND CONTROL POLLUTANTS WITHIN THE SITE IS LEFT TO THE DISCRETION OF THE FIELD ENGINEER. ADDITIONAL DEVICES AS NEEDED SHALL BE INSTALLED TO RETAIN SEDIMENTS AND OTHER POLLUTANTS ON SITE.
9. STORM WATER POLLUTION AND EROSION CONTROL DEVICES ARE TO BE MODIFIED, AS NEEDED, AS THE PROJECT PROGRESSES. THE DESIGN AND PLACEMENT OF THESE DEVICES IS THE RESPONSIBILITY OF THE FIELD ENGINEER. PLANS REPRESENTING CHANGES MUST BE SUBMITTED FOR APPROVAL, IF REQUESTED BY THE BUILDING OFFICIAL.
10. THE CONTRACTOR SHALL PROTECT ALL POINTS OF CONSTRUCTION BUSINESS AND EXPRESS TO PREVENT THE DEPOSITION OF MATERIALS ONTO PUBLIC ROADS. ALL MATERIALS DEPOSITED ONTO PUBLIC ROADS SHALL BE REMOVED IMMEDIATELY.
11. THE CONTRACTOR SHALL INSPECT DAILY AND MAINTAIN CONTINUOUSLY IN AN EFFECTIVE OPERATING CONDITION ALL EROSION AND SEDIMENT CONTROL MEASURES.
12. ALL SEDIMENT BASINS, TRAP CHAMBERS AND SLOPES, PERIMETER DICES, SLOPES AND ALL DISTURBED SLOPES STEEPER THAN OR EQUAL TO 2:1 SHALL BE STABILIZED WITH SOO OR SEED AND ANCHORED STRAW MULCH, OR OTHER APPROVED STABILIZATION MEASURES, AS SOON AS POSSIBLE BUT NO LATER THAN THIRTY (30) CALENDAR DAYS AFTER ESTABLISHMENT. ALL AREAS DESTABILIZED OUTSIDE OF THE PERIMETER SEDIMENT CONTROL SYSTEM MUST BE RESEED. MAINTENANCE MUST BE PERFORMED AS NECESSARY TO ENSURE CONTINUED STABILIZATION.
13. THE CONTRACTOR SHALL APPLY SOO OR SEED AND ANCHORED STRAW MULCH, OR OTHER APPROVED STABILIZATION MEASURE TO ALL DISTURBED AREAS AND STOCKPILES WITHIN THIRTY (30) CALENDAR DAYS AFTER STRIPPING AND GRADING ACTIVITIES HAVE COMPLETED IN THE AREA. MAINTENANCE SHALL BE PERFORMED AS NECESSARY TO ENSURE CONTINUED STABILIZATION.
14. PERMANENT SLOPES OR OTHER POINTS OF CONCENTRATED WATER FLOW SHALL BE STABILIZED WITH SOO OR SEED WITH AN APPROVED EROSION CONTROL MATING, REPAIR OR OTHER APPROVED STABILIZATION MEASURE.
15. ALL POINTS OF CONSTRUCTION BUSINESS AND EXPRESS IN UNPAVED AREAS SHALL BE STABILIZED AND PROTECTED TO PREVENT TRACKING OR WASH ONTO PUBLIC ROADS.
16. CONTRACTOR SHALL FURNISH AND PLACE WATER ON BARE SOIL AS NECESSARY IF DUST CONTROL BECOMES A PROBLEM.
17. THE CONTRACTOR IS RESPONSIBLE FOR THE MAINTENANCE AND REPAIR OF ALL EROSION AND SEDIMENT CONTROL DEVICES DURING UTILITY INSTALLATION AND THE CONTINUED MAINTENANCE AND REPAIR OF ALL SITE PROTECTION MEASURES.
18. ALL SOILS SHALL BE STOCKPILED ON LOW SLOPING AREAS WITHIN A PROTECTED AREA WITH APPROPRIATE SEDIMENT AND EROSION CONTROL PRACTICES INSTALLED.

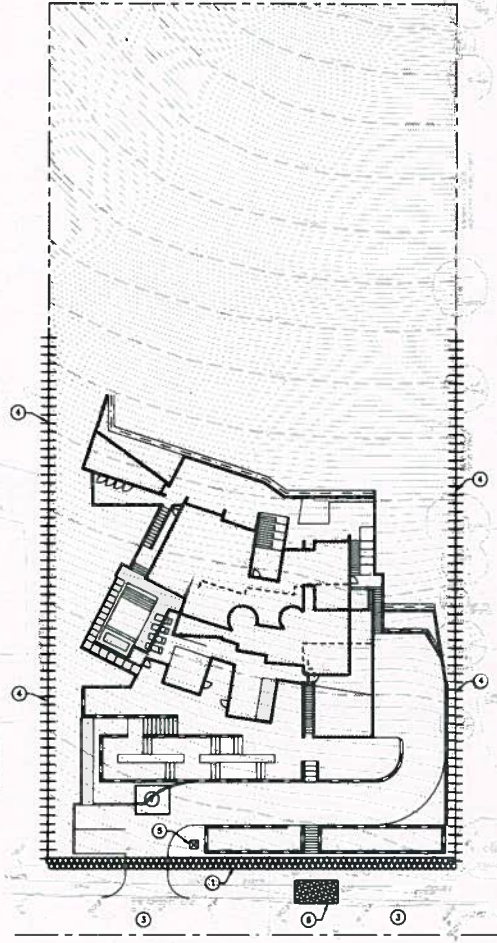

ESCP CONSTRUCTION NOTES

- ① FURNISH AND INSTALL CURB SIP-4E-4, DRAINING SWITCH OR SE-4 DEVICE AND SOO.
- ② PROVIDE EQUIPMENT MAINTENANCE AND USE MATERIAL STORAGE AREA PER CURB SIP-4E-4 AND SIP-4E-1, CONTRACTOR TO LOCATE DURING CONSTRUCTION.
- ③ PROVIDE STREET SWEEPING AND WASHDOWN PER CURB SIP-4E-7, AS NECESSARY.
- ④ FURNISH AND INSTALL CURB SIP-4E-1, SILT FENCE OR CURB SIP-4E-4, FRED BELLS.
- ⑤ PROVIDE EQUIPMENT SWEEPING FACILITIES AND SECONDARY CONTAINMENT PER CURB SIP-4E-4, CONTRACTOR TO LOCATE DURING CONSTRUCTION.
- ⑥ INSTALL CONSTRUCTION SWEEPING AND MATERIAL STORAGE AREA PER CURB SIP-4E-4, CONTRACTOR TO LOCATE DURING CONSTRUCTION.
- ⑦ PROVIDE LINED CONCRETE WASHDOWN BAY AND EQUIPMENT CLEANUP AREA PER CURB SIP-4E-4 AND SIP-4E-2, CONTRACTOR TO LOCATE DURING CONSTRUCTION.



| | | | | | | | | |
|------------|--------|-----------------------|----------|-----------------------------------|-------------------------------|------|-----------------|-----------------------|
| | | | | PREPARED BY: | CITY OF AGOURA HILLS APPROVAL | | | |
| | | | | LUCAS CORSSIE PROJECT ENGINEER | 07/20/17 DATE | | | |
| REVISION # | SYMBOL | DESCRIPTION OF CHANGE | APPROVED | DATE | REVIEWED BY | DATE | 0695 RCE NO. | 09/30/18 EXPI DATE |
| | | | | | RAMIRO ADEVA CITY ENGINEER | | | |



PLANTING NOTES

1. THE WORK TO BE PERFORMED UNDER THIS CONTRACT SHALL INCLUDE FURNISHING ALL LABOR, MATERIALS, TOOLS, MACHINERY AND EQUIPMENT NECESSARY TO INSTALL THE WORK INDICATED ON THE PLANS, IN A COMPLETE FINISHED OPERATING STATE.
2. PLACE A 3" HIGH (MIN.) TOP LAYER OF 1/2" X 1/4" (MIN.) WOOD CHIP MULCH THROUGHOUT ALL PLANTED AREAS EXCEPT NEW AREAS. MULCH SHALL NOT BE COMPRESSED, OR CONTAIN CONSTRUCTION WASTE.
3. AFTER SETTING PLANTS IN PITS, CONTACT BAGS WILL BE 3 INCH LAYERS AND THOROUGHLY SOAK WITH WATER. AFTER SETTLING, TOP OF FOOTING SHALL BE 1" HIGH (MIN.) ABOVE FINISHED FLOOR GRADE.
4. PLANT TREES 10 BUCH (10.3M) MINIMUM FROM DRAINAGE FLOOR LINES SHOULD THIS NOT BE POSSIBLE, CONTACT LANDSCAPE ARCHITECT FOR DECISION ON PLACEMENT.
5. PLANT GROUND COVER IN REGULAR TRIANGULAR SPACING. GROUND COVERS SHALL BE PLANTED UNDER ALL TREES AND SHRUBS. ALL PLANTING AREAS TO BE PLANTED WITH GROUND COVER SHALL BE PLANTED TO WITHIN 12 BUCHES (3.05M) OF BASE OF PLANT OR TREE.
6. ALL PLANT MATERIAL SHALL BE SUBJECT TO APPROVAL BY THE LANDSCAPE ARCHITECT PRIOR TO INSTALLATION. LANDSCAPE ARCHITECT MAY SELECT PLANT MATERIALS PLANTED WITHOUT PRIOR APPROVAL.
7. HIGH BUSH SHRUBS - @ COMPLETED CONTRACTOR SHALL SUBMIT TO THE LANDSCAPE ARCHITECT AN AEROSOLIC SOIL REPORT PREPARED BY A CERTIFIED SOIL LABORATORY. AFTER THE SITE SOILS AND PLANTING BACKFILL AS RECOMMENDED IN THE REPORT, ONCE APPROVED BY THE LANDSCAPE ARCHITECT, ANY CHANGES TO SOIL AMENDMENTS AND CONDITIONS AS SHOWN SHALL BE CREDITED TO THE OWNER OR CONTRACTOR AS APPROPRIATE.
8. REMOVE ALL WASTE MATERIALS DAILY.
9. PLANT QUANTITIES SHOWN ARE FOR CONTRACTOR'S CONVENIENCE ONLY. BID QUANTITIES SHALL BE DETERMINED FROM A COUNT ON THE FIELD. PAY QUANTITIES SHALL BE DETERMINED FROM A COUNT IN THE FIELD.
10. BACKFILL ON DEVICE SHALL BE SCREENED WITH 3/8" SIAL SCREENS AS DIRECTED BY THE LANDSCAPE ARCHITECT.
11. INSTALL 24" DEPTH ROOT BARRIER ALONG THE LENGTH OF CURB, PAVEMENT OR DRIVEWAY WITHIN TEN FEET OF A 1/2" SIAL CURB OR LAWNED SIDE WALK. ROOT BARRIER SHALL BE HOUSING/TORONTO, DRIPROOF, OR EQUAL.
12. NO AREA SHALL BE LEFT BARE UNLESS SPECIFICALLY CALLED OUT AS BARE ON THE PLANS.
13. SEPARATE TURF FROM OTHER LANDSCAPE AREAS BY INSTALLING 2" X 4" (MIN.) RECYCLED 2X VIBRIB MATS WITH 1/2" (MIN.) W/STABILIZER. PLASTIC UNDER AT TURF EDGES UNLESS NOTED OTHERWISE ON PLAN. 1" SH-7 INCHES IS NOT ACCEPTABLE.
14. CONTRACTOR SHALL NOT DEVIATE FROM THE PLAN WITHOUT THE APPROVAL OF THE LANDSCAPE ARCHITECT. LANDSCAPE ARCHITECT CANNOT BE RESPONSIBLE FOR COMPLIANCE FOR UNAPPROVED REINSTALLATION.
15. REMOVE THE RUBBER STAMPS FROM THE TREES AT THE TIME OF PLANTING. TREES THAT PLOP OR BEND EXCESSIVELY ARE SELECTED PROBABLY.
16. ALL TREES SHALL BE "STANDARD" UNLESS CALLED OUT OTHERWISE.
17. CONTRACTOR SHALL CLEAR AND GRUB ALL AREAS SHOWN TO BE PLANTED.
18. CONTRACTOR SHALL GRADE ALL PLANTING AREAS TO DRAIN PROPERLY.

AGOURA HOUSE
335 CANYONVIEW AVE. SUITE 101
NORTH HOLLYWOOD, CA 91301
1310AMPT07730000000000

AGOURA HOUSE
335 CANYONVIEW AVE. SUITE 101
NORTH HOLLYWOOD, CA 91301
1310AMPT077300000000000000

AGOURA HOUSE
335 CANYONVIEW AVE. SUITE 101
NORTH HOLLYWOOD, CA 91301
1310AMPT077300000000000000

AGOURA HOUSE
335 CANYONVIEW AVE. SUITE 101
NORTH HOLLYWOOD, CA 91301
1310AMPT077300000000000000

NON-IRRIGATED
FUEL MODIFICATION ZONE
PER LA FIRE DEPT
HILLSIDE TO REMAIN IN
NATIVE CONDITION
MAINTAIN PER LA COUNTY FIRE DEPT.
REQUIREMENTS

DROUGHT TOLERANT
DEER GRASS

TYPICAL HEADER

UNIMPOVED DROUGHT TOLERANT
BUFFALO GRASS

RIVER ROCK COBBLES

3" LAYER WOOD CHIP MULCH
TRUCKS IN SELECT LOCATIONS

FUEL MOD ZONE A
DISTANCE FROM NEIGHBOR

OUTLINE OF BUILDING PRIMARY
ENVELOPE/STRUCTURE
FUEL MOD MEASURED FROM HERE

SPECIMEN TREE
IN DECOMPOSED GRANITE SURFACE

FLOWERING TREES
IN DECOMPOSED GRANITE SURFACE

COMPACTED CRUSHED ROCK
FOR PARKING AND SUITABLE FOR WALKING

HEADER AT PROPERTY LINE

DRIVEWAY SURFACE PER ARCHITECT

COMPACTED CRUSHED ROCK
FOR PARKING AND SUITABLE FOR WALKING
(IN RIGHT OF WAY)

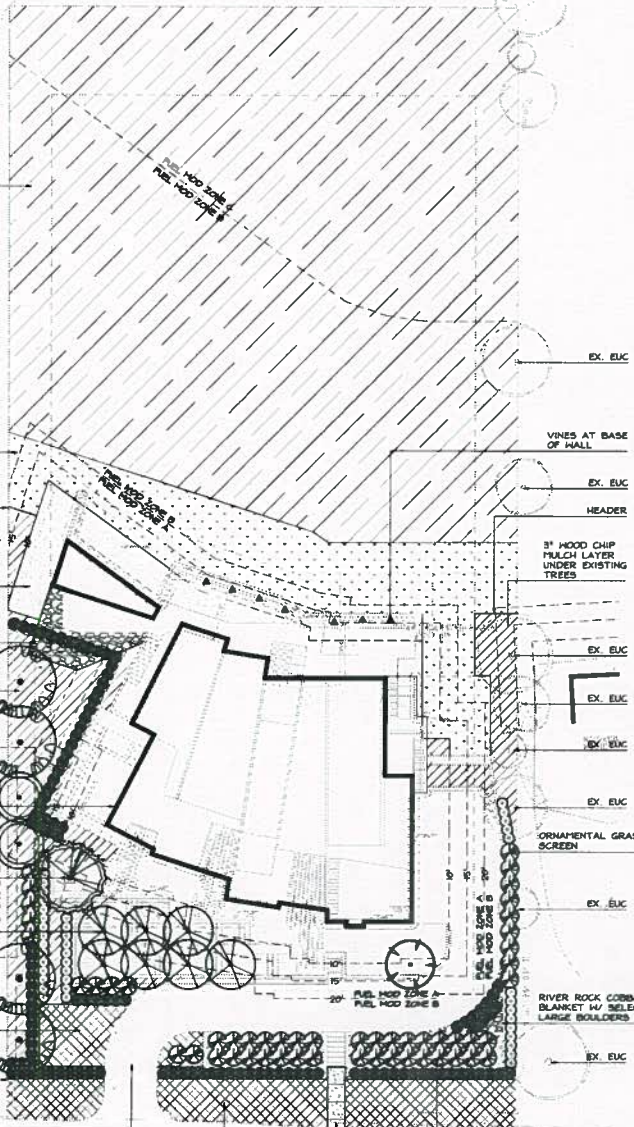

| SYMBOL | DESCRIPTION | QTY | REMARKS | UNITS | EST. COST |
|----------|---|------|----------------------|-------|-----------|
| (Symbol) | 3" LAYER WOOD CHIP MULCH | 1.00 | SEE PLAN FOR DETAILS | 0.00 | 0.00 |
| (Symbol) | UNIMPOVED DROUGHT TOLERANT BUFFALO GRASS | 1.00 | SEE PLAN FOR DETAILS | 0.00 | 0.00 |
| (Symbol) | 3" HOOD CHIP MULCH LAYER UNDER EXISTING TREES | 1.00 | SEE PLAN FOR DETAILS | 0.00 | 0.00 |
| (Symbol) | RIVER ROCK COBBLES | 1.00 | SEE PLAN FOR DETAILS | 0.00 | 0.00 |
| (Symbol) | COMPACTED CRUSHED ROCK FOR PARKING AND SUITABLE FOR WALKING | 1.00 | SEE PLAN FOR DETAILS | 0.00 | 0.00 |
| (Symbol) | DRIVEWAY SURFACE PER ARCHITECT | 1.00 | SEE PLAN FOR DETAILS | 0.00 | 0.00 |
| (Symbol) | COMPACTED CRUSHED ROCK FOR PARKING AND SUITABLE FOR WALKING (IN RIGHT OF WAY) | 1.00 | SEE PLAN FOR DETAILS | 0.00 | 0.00 |
| (Symbol) | CONCRETE SIDEWALK FINISH PER ARCHITECT | 1.00 | SEE PLAN FOR DETAILS | 0.00 | 0.00 |

FUEL MOD REVISIONS
PLANTING

SCALE: 1/8" = 1'-0"



AGOURA HOUSE

AGOURA HOUSE

AGOURA HOUSE

PLANTING PLAN

L-01

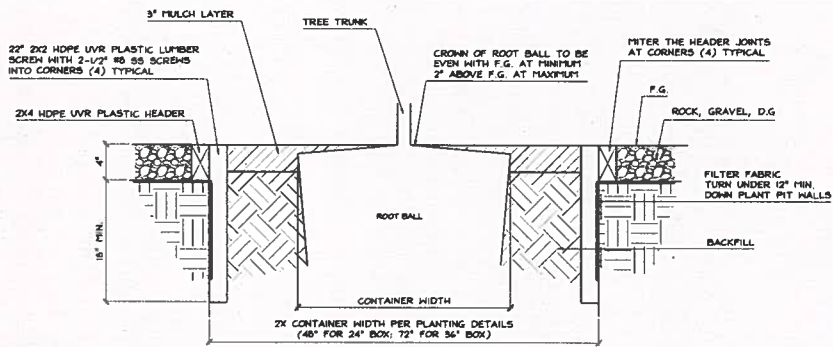

NOTES:
 1. EDGE "BOX" SHALL BE SQUARE 90 DEGREE CORNERS, LEVEL WITH FINISHED GRADE
 2. EDGE BOX SHALL BE SQUARE TO NEARBY WALKS OR WALLS (ORTHOGONAL, TWO SIDE PARALLEL, TWO SIDE PERPENDICULAR)

7A. EDGE OF TREE PLANTING PIT IN ROCK, GRAVEL, DECOMPOSED GRANITE

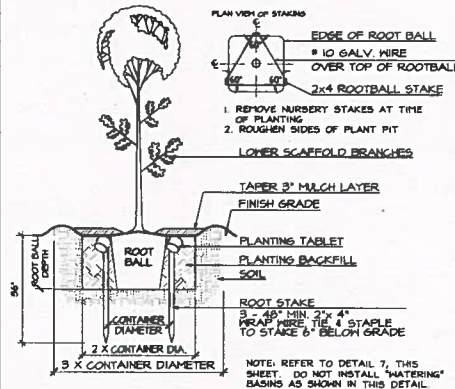

4. TREE ROOT STAKING (36" BOX +)

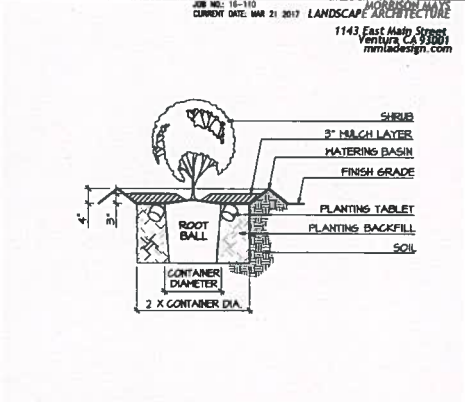

1. SHRUB PLANTING (1 GAL - 15 GAL)

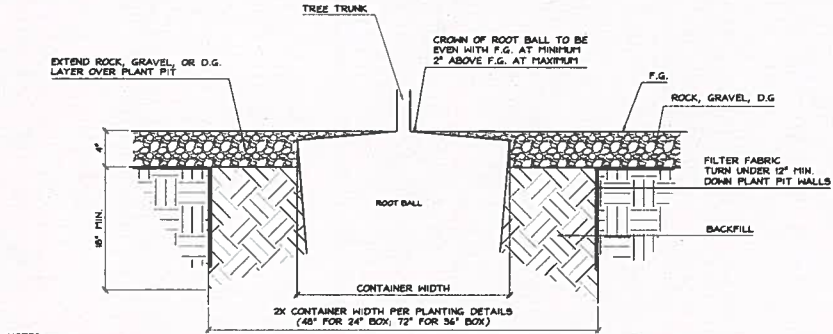

NOTES:
 1. ALTERNATE DETAIL ELIMINATING EDGING FOR TREES IN ROCK/GRAVEL, OR D.G. SHALL BE AT LEAD ARCHITECT'S DISCRETION.
 2. COMPACT BACKFILL PRIOR TO INSTALLING ROCK/D.G. LAYER. DO NOT OVER COMPACT.
 3. OWNER SHALL MAINTAIN ROCK/GRAVEL/D.G. AT FINISHED GRADE IF BACKFILL SETTLES.

7B. ALTERNATE TREE PLANTING PIT IN ROCK/GRAVEL/D.G.

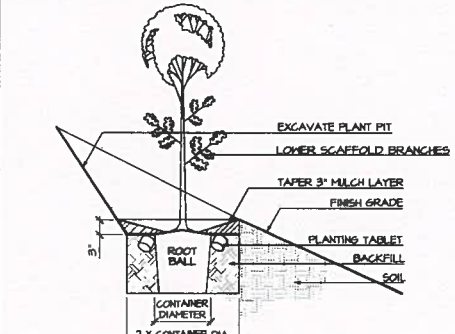

5. TREE PLANTING ON SLOPE

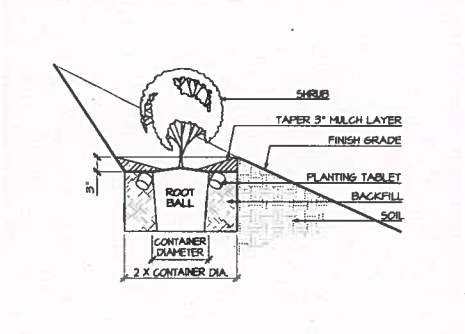

2. SHRUB PLANTING ON SLOPE

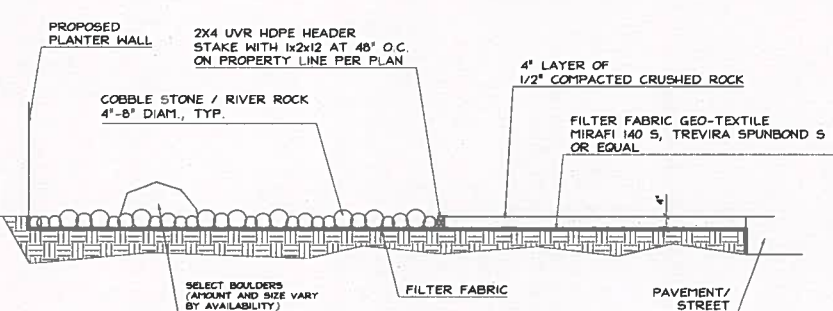

NOTES:
 1. FILL MATERIAL MAY BE CRUSHED ROCK OR D.G., SEE PLANS
 2. LEAVE FILTER FABRIC LOOSE TO RESIST TEARING
 3. HEADER TO REMAIN HIDDEN AND SECURE FABRIC.

8. RIVER ROCK COBBLES AND BOULDERS / FILL IN R/W

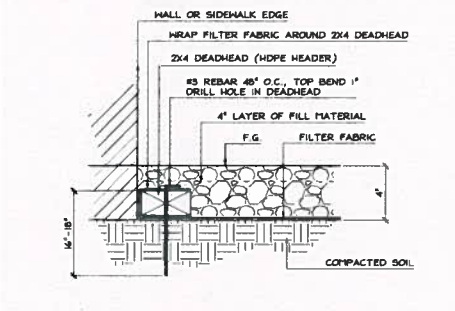

NOTES:
 1. FILL MATERIAL MAY BE CRUSHED ROCK OR D.G., SEE PLANS
 2. LEAVE FILTER FABRIC LOOSE TO RESIST TEARING
 3. HEADER TO REMAIN HIDDEN AND SECURE FABRIC.

6. EDGE OF ROCK/D.G. SPACE

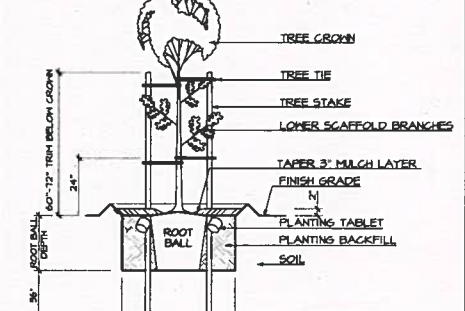

NOTE: REFER TO DETAIL 7, THIS SHEET, DO NOT INSTALL "WATERING" BASINS AS SHOWN IN THIS DETAIL.
 1. REMOVE NURSERY STAKES AT TIME OF PLANTING
 2. ROUGHEN SIDES OF PLANT PIT

3. TREE DOUBLE STAKING DETAIL

MR. ARCHITECT
 MORRISON WAYS
 LANDSCAPE ARCHITECTURE
 1143 East Main Street
 Ventura, CA 93001
 mmwdesign.com

PROJECT
 AGOURA HOUSE
 1515 CANTONMENT AVE, SUITE 101
 AGOURA HILLS, CALIFORNIA 91301
 11/14/2017 11:00:00 AM

DATE
 11/14/2017

BY
 M. WAYS

SCALE
 AS SHOWN

PROJECT ADDRESS
 1515 CANTONMENT AVE, SUITE 101
 AGOURA HILLS, CALIFORNIA 91301

PROJECT NUMBER
 L-02

PROJECT
 AGOURA HOUSE

PROJECT ADDRESS
 1515 CANTONMENT AVE, SUITE 101
 AGOURA HILLS, CALIFORNIA 91301

PROJECT NUMBER
 L-02

PROJECT
 AGOURA HOUSE

PROJECT ADDRESS
 1515 CANTONMENT AVE, SUITE 101
 AGOURA HILLS, CALIFORNIA 91301

PROJECT NUMBER
 L-02

IRRIGATION NOTES

1. THE WORK TO BE PERFORMED UNDER THIS CONTRACT SHALL INCLUDE FURNISHING ALL LABOR, MATERIALS, TOOLS, MACHINERY, AND EQUIPMENT NECESSARY TO INSTALL A COMPLETE OPERATING AUTOMATIC IRRIGATION SYSTEM AS SHOWN ON PLANS AND DETAILS HEREON.
2. CONTRACTOR SHALL APPLY AND PAY FOR ALL PERMITS REQUIRED FOR INSTALLATION OF THE IRRIGATION SYSTEM EXCEPT ELECTRICAL SUPPLY.
3. ALL WORKMANSHIP AND MATERIALS SHALL CONFORM TO UNIFORM PLUMBING CODES AND ALL STATE AND LOCAL CODES.
4. AT THE END OF EACH WORK DAY, THE SITE SHALL BE CLEANED OF EXCESS OR WASTE MATERIALS. AT THE END OF WORK, ALL SUCH MATERIALS SHALL BE REMOVED FROM THE SITE.
5. IT IS THE INTENT OF THESE DOCUMENTS TO INDICATE A COMPLETE IRRIGATION SYSTEM READY FOR USE WITHOUT FURTHER COST TO THE OWNER.
6. DO NOT RELIABLY INSTALL THE IRRIGATION SYSTEM AS SHOWN ON THE PLANS WHEN IT IS OBVIOUS IN THE FIELD THAT UNCOMMON OBSTRUCTIONS OR GRADE DIFFERENCES EXIST. THE CONTRACTOR SHALL IMMEDIATELY NOTIFY THE LANDSCAPE ARCHITECT PRIOR TO PROCEEDING WITH THE WORK.
7. CONTRACTOR TO COORDINATE PIPING AND SLEEVINGS WITH HARDSCAPE INSTALLATION.
8. DRAWINGS ARE DIAGNOSTIC. PLACE IRRIGATION LINES AND EQUIPMENT IN PLANTING AREAS.
9. PIPE RUNNING UNDER PAVING SHALL BE SLEEVED WITH SCHEDULE 40 PVC SLEEVE. SLEEVES SHALL BE THREE TIMES THE SIZE OF THE ENCLOSED PIPE DIAMETER. SEE IRRIGATION DETAILS FOR PIPE AND PIPE SLEEVE DETAILS.
10. IRRIGATION SLEEVES UNDER STREET PAVING SHALL BE 30" MIN. FROM FINISHED SURFACE. REFER TO DETAILS.
11. A PLASTIC LAMINATED, COLOR CODED REDUCED SIZE IRRIGATION PLAN SHALL BE FURNISHED TO THE OWNER AFTER FINAL ACCEPTANCE OF THE CONTRACT. PLACE ANOTHER LAMINATED COPY INSIDE THE CONTROLLER CABINET DOOR.
12. A GUARANTEE OF ONE FULL YEAR SHALL BE GRANTED BY THE CONTRACTOR ON THE IRRIGATION SYSTEM AS INSTALLED, EXCLUDING UNUSUAL ACTS OF VANDALISM. CONTRACTOR SHALL BE LIABLE FOR REPAIRS AND REPLACEMENT OF FAILED MATERIAL DURING THIS GUARANTEE PERIOD.
13. THE SPRINKLER SYSTEM IS NOT CONSIDERED COMPLETE UNTIL ALL VALVES, HEADS, CONTROLLERS, AND RELATED EQUIPMENT HAVE BEEN INDIVIDUALLY ADJUSTED FOR MAXIMUM COVERAGE WITH A MINIMUM OF OVERSPRAY ON ALL BUILDING FENCES, PATIOWAYS, DRIVEWAYS, OR OTHER SITE FACILITIES.
14. FURNISH 4 GROUND-WATER VALVE KEYS TO THE OWNER-NOT-REQUIRED.
15. MAINLINE PRESSURE TEST AT 120 PSI FOR TWO HOURS IS REQUIRED, WITH VERIFICATION BY THE APPROVED AGENCY.
16. DESIGN PRESSURE IS 30 PSI OR AS INDICATED ON THE IRRIGATION LEGEND.
17. THE LANDSCAPE CONTRACTOR SHALL PROVIDE A MAINTENANCE SCHEDULE TO THE OWNER PRIOR TO ISSUANCE OF A CERTIFICATE OF OCCUPANCY. FURNISH A COPY OF THIS SCHEDULE TO THE LANDSCAPE ARCHITECT.
18. THESE PLANS CONFORM WITH THE PUBLIC LANDSCAPE STANDARDS. DO NOT DEVIATE FROM THE PLANS WITHOUT THE APPROVAL OF THE LANDSCAPE ARCHITECT.
19. DO NOT INSTALL SPRINKLER NOZZLES ON RISERS UNLESS SPECIFICALLY DIRECTED TO DO SO ON THE PLANS OR BY THE LANDSCAPE ARCHITECT.
20. PIPE ON SLOPES 2% OR MORE SHALL BE 1/4" PVC ON GRADE. SECURE PIPE TO GRADE BY 3/8" X 1/4" NIP LONG STEEL RIBBON HOODS. NOZZLES ON SLOPE MAY BE ON 12" SCH 80 PVC RISERS.

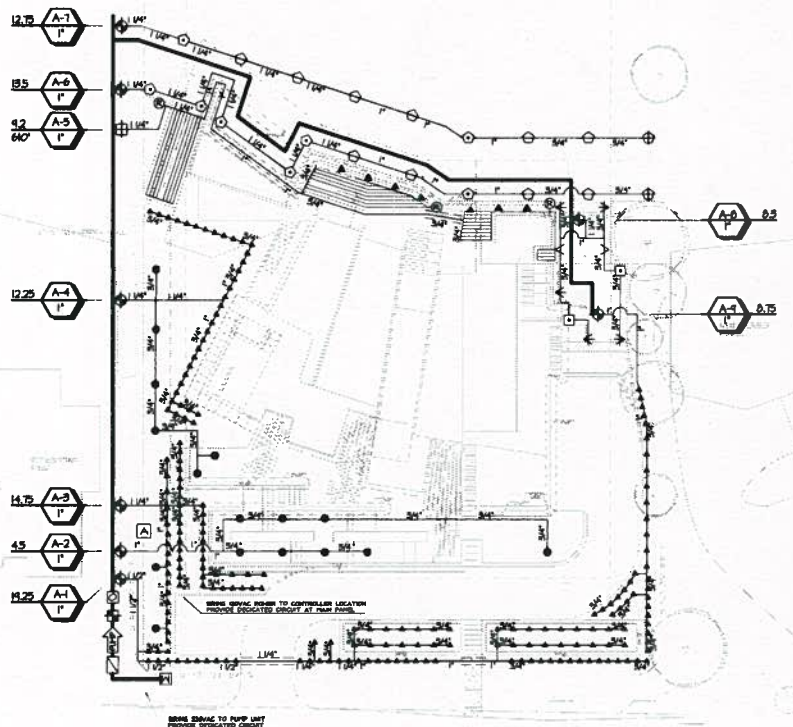

BRING SPRING POWER TO CONTROLLER LOCATION
 PROVIDED INDICATED ON PLAN, SEE SPEC.

IRRIGATION EQUIPMENT - LIGHT/RESIDENTIAL

| SYMBOL | DESCRIPTION | MANUFACTURER | MODEL | REMARKS |
|--------|--|------------------------------|--|---|
| [A] | AUTOMATIC CONTROLLER W/ ET BASED MODULE FLOW SENSING MASTER VALVE CONTROL | RAIN BIRD | ESP-1214-LO-HEF 16 STATION CONTROLLER W/ FLOW SENSING 4" ET MANAGER CARTRIDGE* | MOUNT CONTROLLER INSIDE BUILDING OR MOUNT OUTSIDE IN WEATHERPROOF ENCLOSURE. INSTALL PER MFR SPECS. CONNECT PUMP START RELAY |
| [M] | MASTER CONTROL VALVE IN 1/4" RECT. VALVE BOX | BUCKNER/SUPERIOR | 3000-850 1.5" NORMALLY CLOSED | IN 1/4" RECT. VALVE BOX CONNECT TO CONTROLLER MASTER VALVE PORT |
| [F] | FLOW SENSOR | RAINBIRD | FS-50P (1/2") | IN 1/4" RECT. VALVE BOX INSTALL PER MANUFACTURER REQUIREMENTS FULL COMPHES TO CONTROLLER LOCATION CONNECT PER MFR'S INSTRUCTIONS |
| [Z] | BACKFLOW PREVENTER (NO ENCLOSURE) | FEBCO | 6.5" SIZE 1" | |
| [R] | PRESSURE REGULATOR | VELKO | 300 SERIES | NON-SPRING RANGE 10-120 PSI SET GUILTY PRESSURE 10-40-50 PSI |
| [M] | IRRIGATION MAINLINE 18" DEEP | PACIFIC PLASTICS OR EQUAL | 1/2" SCH 40 PVC | ALL PIPE CROSSING DRIVEWAY AND/OR SIDEWALK AREAS SHALL BE SLEEVED |
| [M] | IRRIGATION LATERAL 12" DEEP | PACIFIC PLASTICS OR EQUAL | CL 200 PVC SIZE PER PLAN | |
| [M] | PIPE SLEEVE | PACIFIC PLASTICS OR EQUAL | SCHEDULE 40 PVC | 3" MINIMUM - INSTALL BEFORE PAVING (2X ENCLOSED PIPE DIAMETER - 3" MIN) |
| [V] | SHUTOFF VALVE | KINGS BROTHERS KEN | 3/4" SCH 40 PVC - LINE SIZE BALL VALVE | LINE SIZE - IN 10" ROUND VALVE BOX SEE DETAIL |
| [R] | REMOTE CONTROL VALVE IN 1/4" RECT. VALVE BOX | HUNTER | PEV-406 1" GLOBE W/ FLOW CONTROL 0.2 TO 40 GPM | IN 1/4" RECT. VALVE BOX |
| [R] | REMOTE CONTROL VALVE PRESSURE REGULATING FILTER | RAINBIRD | XCL-PRE-100-COM | IN 1/4" RECT. VALVE BOX SET PRESSURE REGULATOR AT 35 PSI |
| [M] | IRRIGATION WATER METER | PER WATER AGENCY | 3/4" SIZE | COORDINATE INSTALLATION WITH WATER SERVICE AGENCY |
| [A] | AIR RELIEF VALVE | RAINBIRD | ARY-50 | IN RAINBIRD 50# VALVE BOX 6" TOP DIAM |

PUMP SPECIFICATIONS

| SYMBOL | DESCRIPTION | MFR | MODEL | TYPE | HORSEPOWER | PERFORMANCE RANGE AT SET SUCTION LIFT | INLET SIZE | DISCHARGE SIZE | VOLTAGE | ENCLOSURE |
|--------|---------------|----------|-------|----------------------|------------|--|------------|----------------|---------|-----------|
| [P] | PUMP ASSEMBLY | RAINBIRD | LC750 | SUCTION LIFT BOOSTER | 3/4 HP | 20 PSI @ 0.5 GPM 40 PSI @ 25 GPM | 2" | 1-1/2" | 230V | INCLUDED |

ELECTRICAL CONTRACTOR TO PROVIDE 230V DEDICATED CIRCUIT TO PUMP STATION, CONNECT AT DOMESTIC MAIN PANEL.

IRRIGATION HEAD LEGEND

| SYMBOL | PATTERN | DESCRIPTION | MAKE | BODY/FEATURES | NOZZLE | PSI | RAD* | GPH | INH | REMARKS |
|--------|--------------------------------------|------------------|----------|---------------|------------|-------|-------|---------------------------|-------|--|
| [C] | HALF CIRCLE | ROTARY ON RISER | RAINBIRD | PA-85 ADAPTER | R11-24 H | 30 | 11-24 | 130 | 0.65 | RISER HEIGHT 18" ABOVE F.S. 1/4" INLINE 1/2" SPRING CHECK |
| [C] | 1/4 CIRCLE | ROTARY ON RISER | RAINBIRD | PA-85 ADAPTER | R11-24 G | 30 | 11-24 | 0.75 | 0.65 | |
| [C] | VARIABLE | ROTARY ON RISER | RAINBIRD | PA-85 ADAPTER | RVAN 11-24 | 30 | 11-24 | VARIES | | |
| [S] | VARIABLE | SPRAY ON RISER | RAINBIRD | PA-85 ADAPTER | 15VAN | 30 | 15' | 0.83 | 1.50 | RISER HEIGHT 12" ABOVE F.S. 1/4" INLINE 1/2" SPRING CHECK |
| [S] | 1/4 CIRCLE | SPRAY ON RISER | RAINBIRD | PA-85 ADAPTER | 12H | 30 | 12 | 130 | 1.74 | |
| [S] | 1/4 CIRCLE | SPRAY ON RISER | RAINBIRD | PA-85 ADAPTER | 12G | 30 | 12 | 0.65 | 1.74 | |
| [S] | 1/4 CIRCLE | SPRAY ON RISER | RAINBIRD | PA-85 ADAPTER | 10H | 30 | 10' | 0.71 | 1.52 | |
| [S] | 1/4 CIRCLE | SPRAY ON RISER | RAINBIRD | PA-85 ADAPTER | 10G | 30 | 10' | 0.91 | 1.52 | |
| [S] | HALF CIRCLE | SPRAY ON RISER | RAINBIRD | PA-85 ADAPTER | 8H | 30 | 8' | 0.52 | 1.58 | |
| [S] | VARIABLE | SPRAY ON RISER | RAINBIRD | PA-85 ADAPTER | 8VAN | 30 | 8' | 0.52 | 0.78 | |
| [S] | HALF CIRCLE | SPRAY ON RISER | RAINBIRD | PA-85 ADAPTER | 5H | 30 | 5' | 0.20 | 1.50 | |
| [S] | 1/4 CIRCLE | SPRAY ON RISER | RAINBIRD | PA-85 ADAPTER | 5G | 30 | 5' | 0.10 | 1.50 | |
| [B] | DRIP BUBBLER | BUBBLER ASSEMBLY | RAINBIRD | ON 1/2" NPT | 1402 | 20-40 | 0' | 0.50 | * | IN BUBBLER ASSEMBLY 1/4" 1/2" KBI SPRING CHECK |
| [B] | DRIP BUBBLER | BUBBLER ON RISER | RAINBIRD | ON 1/2" NPT | 1401 | 20-40 | 0' | 0.25 | * | RISER HEIGHT 3" ABOVE F.S. 1/4" 1/2" KBI SPRING CHECK |
| [S] | SUBSURFACE DRIP LINE FOR TURFLAWN | | RAINBIRD | XFS-01-12 | | 15-50 | 0' | 0.4 GPH PER FOOT | 1.445 | 4" BELOW FINISHED GRADE 0.4 GPH/FT 0.05 GPH/FT SPACE PIPE 12" APART |

REFER TO IRRIGATION SPECIFICATIONS SHEET FOR WATER BUDGET (MAMB) AND ESTIMATED WATER USE (ETM) CALCULATIONS

IRRIGATION PLAN

SCALE: 1/16"=1'-0"



100 CARLYN RD. SUITE 100
 NORTHBAYWOOD, CA 94941
 TEL 415-451-7733 FAX 415-451-7058

AGOURA HOUSE

100 CARLYN RD. SUITE 100
 NORTHBAYWOOD, CA 94941
 TEL 415-451-7733 FAX 415-451-7058

100 CARLYN RD. SUITE 100
 NORTHBAYWOOD, CA 94941
 TEL 415-451-7733 FAX 415-451-7058

100 CARLYN RD. SUITE 100
 NORTHBAYWOOD, CA 94941
 TEL 415-451-7733 FAX 415-451-7058

100 CARLYN RD. SUITE 100
 NORTHBAYWOOD, CA 94941
 TEL 415-451-7733 FAX 415-451-7058

100 CARLYN RD. SUITE 100
 NORTHBAYWOOD, CA 94941
 TEL 415-451-7733 FAX 415-451-7058



100 CARLYN RD. SUITE 100
 NORTHBAYWOOD, CA 94941
 TEL 415-451-7733 FAX 415-451-7058



Call 4 Days Before We Dig

100 CARLYN RD. SUITE 100
 NORTHBAYWOOD, CA 94941
 TEL 415-451-7733 FAX 415-451-7058

AGOURA HOUSE

100 CARLYN RD. SUITE 100
 NORTHBAYWOOD, CA 94941
 TEL 415-451-7733 FAX 415-451-7058

100 CARLYN RD. SUITE 100
 NORTHBAYWOOD, CA 94941
 TEL 415-451-7733 FAX 415-451-7058

100 CARLYN RD. SUITE 100
 NORTHBAYWOOD, CA 94941
 TEL 415-451-7733 FAX 415-451-7058

| DATE | DESCRIPTION |
|------|-------------|
| | |
| | |
| | |
| | |
| | |
| | |

100 CARLYN RD. SUITE 100
 NORTHBAYWOOD, CA 94941
 TEL 415-451-7733 FAX 415-451-7058

IRRIGATION PLAN

100 CARLYN RD. SUITE 100
 NORTHBAYWOOD, CA 94941
 TEL 415-451-7733 FAX 415-451-7058

100 CARLYN RD. SUITE 100
 NORTHBAYWOOD, CA 94941
 TEL 415-451-7733 FAX 415-451-7058

100 CARLYN RD. SUITE 100
 NORTHBAYWOOD, CA 94941
 TEL 415-451-7733 FAX 415-451-7058

100 CARLYN RD. SUITE 100
 NORTHBAYWOOD, CA 94941
 TEL 415-451-7733 FAX 415-451-7058

100 CARLYN RD. SUITE 100
 NORTHBAYWOOD, CA 94941
 TEL 415-451-7733 FAX 415-451-7058

100 CARLYN RD. SUITE 100
 NORTHBAYWOOD, CA 94941
 TEL 415-451-7733 FAX 415-451-7058

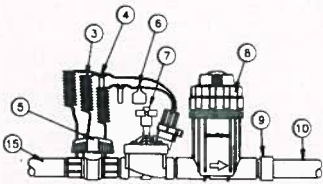

- ③ 30-INCH LINEAR LENGTH OF WIRE, COILED
- ④ WATERPROOF CONNECTION: RAIN BIRD DS SERIES
- ⑤ 1-INCH BALL VALVE (INCLUDED IN XCZ-PRB-100-COM KIT)
- ⑥ ID TAG
- ⑩ MAINLINE PIPE
- ⑦ REMOTE CONTROL VALVE: RAIN BIRD PEB (INCLUDED IN XCZ-PRB-100-COM KIT)
- ⑧ PRESSURE REGULATING QUICK CHECK BASKET FILTER: RAIN BIRD PRB-QKCHK-100 (INCLUDED IN XCZ-PRB-100-COM KIT)
- ⑨ PVC SCH 40 FEMALE ADAPTOR
- ⑩ LATERAL PIPE

NOTE: USE FOR SUBSURFACE DRIP IRRIGATION. SEE PLANS, SEE VALVE IN VALVE BOX DETAIL, THIS SHEET, FOR VALVE BOX.

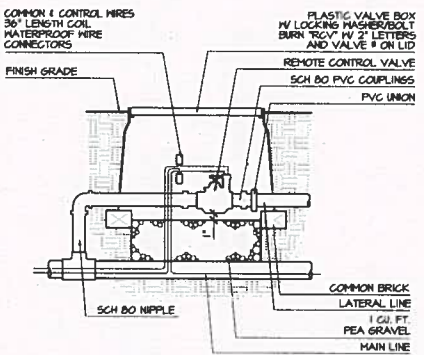

NOTE: COMPACT SOIL AROUND BOX BEFORE JETTING TRENCH

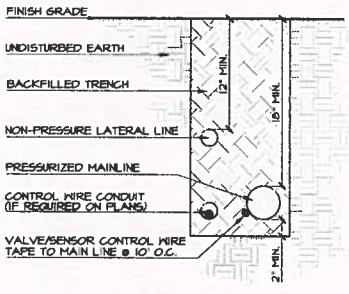

NOTE: PROVIDE 2" OF CLEAN BACKFILL UNDER ALL PIPE

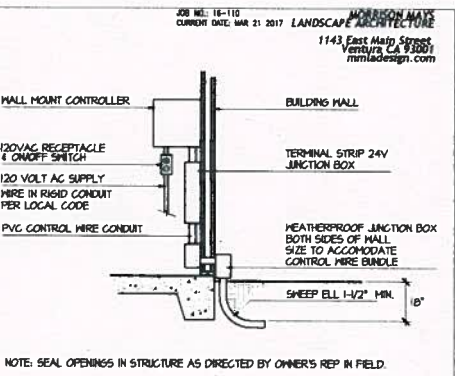

NOTE: SEAL OPENINGS IN STRUCTURE AS DIRECTED BY OWNER'S REP IN FIELD.

10. SUBSURFACE DRIP VALVE

7. REMOTE CONTROL VALVE IN BOX

4. TRENCH AND PIPE

1. WALL MOUNT CONTROLLER

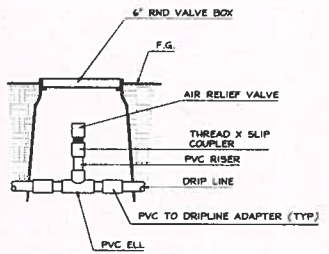

NOTE: SUBSURFACE DRIP LINE TO BE INSTALLED 4" BELOW F.G., PER MANUFACTURER'S INSTRUCTIONS.

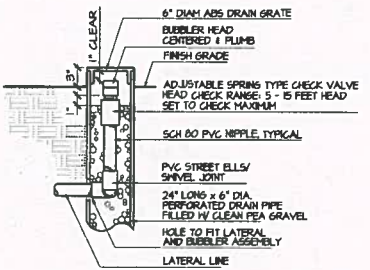

8. BUBBLER ASSEMBLY

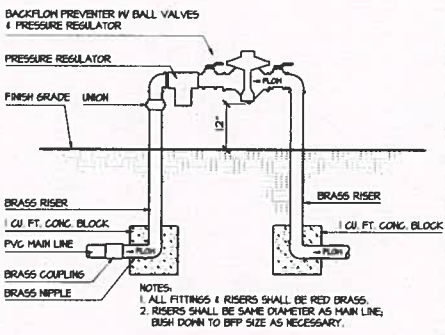

NOTES:
1. ALL FITTINGS & RISERS SHALL BE RED BRASS.
2. RISERS SHALL BE SAME DIAMETER AS MAIN LINE, BUSH DOWN TO DRP SIZE AS NECESSARY.

5. BACKFLOW DEVICE

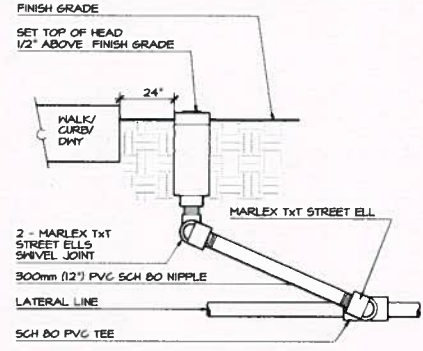

NOTE: INSTALL POP UP FLOOD BUBBLERS 4"-6" FROM PLANTS, INSIDE WATER BASINS - REFER TO PLANS

2. POP UP HEAD

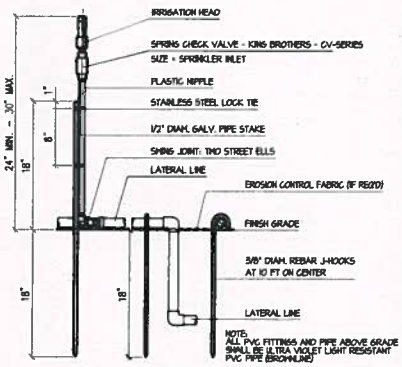

12. IRRIGATION ABOVE GRADE

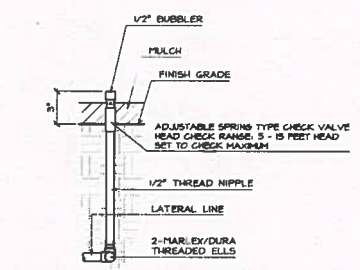

NOTE: 1. PLACE RISER AND BUBBLER WITHIN 4" OF PLANT ROOT BALL.

9. BUBBLER/EMITTER ON RISER

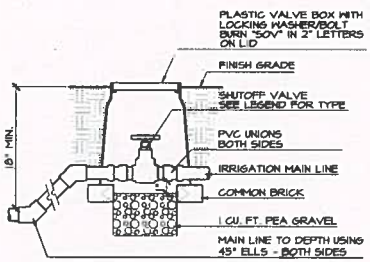

NOTE: COMPACT SOIL AROUND BOX BEFORE JETTING TRENCH

6. SHUTOFF VALVE

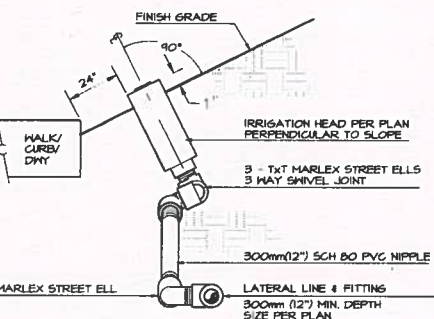

NOTE: IRRIGATION HEAD PER PLAN PERPENDICULAR TO SLOPE

3. POP UP HEAD ON SLOPE

MOHRSON MATS LANDSCAPE ARCHITECTURE
1143 East Main Street
Ventura, CA 93001
mmllandscape.com

AGOURA HOUSE
3333 CANTRELL AVE, SUITE 118
NORTH HOLLYWOOD, CA 91343
PH: 818.708.1234
FAX: 818.708.1235

AGOURA HOUSE
3333 CANTRELL AVE, SUITE 118
NORTH HOLLYWOOD, CA 91343
PH: 818.708.1234
FAX: 818.708.1235

AGOURA HOUSE
3333 CANTRELL AVE, SUITE 118
NORTH HOLLYWOOD, CA 91343
PH: 818.708.1234
FAX: 818.708.1235

AGOURA HOUSE
3333 CANTRELL AVE, SUITE 118
NORTH HOLLYWOOD, CA 91343
PH: 818.708.1234
FAX: 818.708.1235

IRRIGATION SPECIFICATIONS

IRRIGATION SPECIFICATIONS
PART 1.0 - GENERAL
1.1 DESCRIPTION
A. Furnish all labor, materials, and equipment required to provide a complete automatic operating irrigation system as indicated on the drawings and in these specifications.

B. References to LARG indicate the Landscape Architect, Curtis P. Sillars, and his authorized representative.
1.2 REQUIREMENTS OF REGULATORY AGENCIES
A. Comply with all local and state codes, ordinances, orders, and regulations of all legally constituted authorities having jurisdiction over this work.

1.3 SUBMITTALS
A. Submit materials list(s) to the LARG within ten calendar days of award of contract and before beginning irrigation work.
B. Submit to LARG record drawing(s) showing dimensioned locations of pipes, valves, wire runs, irrigation heads, sensors, and controller.

1.4 MATERIALS TO BE FURNISHED
A. Furnish the following materials to the Owner before final inspection.
1. Two keys and one lock or lock core (installed for each locking cabinet and/or enclosure.
2. Manufacturer's literature for each type of controller.

1.5 OBSERVATIONS
A. The following observations shall be made by the LARG.
1. Mainline pressure test.
2. Irrigation coverage test.
3. Pressurize the mainline to 125 PSI for one hour. Pipe may be center loaded with backfill, but all fittings shall be uncovered.

1.6 MAINTENANCE
A. The irrigation system shall consist of the LARG's observation of the completed irrigation system in operation.
B. Do not allow or cause any irrigation work to be covered or enclosed before observation or testing. Work covered before observation by LARG shall be uncovered by the Contractor at no expense to the Owner.

1.7 INSPECTION
A. Make required repairs or changes within five days of notification from the LARG.
B. Supply all necessary equipment and gauges to accomplish testing.

1.8 WATER APPLICATION RATES
A. Maximum Applied Water Allowance (gallons per year)
MAWA = (ET) (A) (30.5 x LA) + (0.8 x SLA)
ET = Reference ET (inches per year)
0.8 = Conversion Factor (inches to S.A. gallons/feet)
0.55 = ET Adjustment Factor (ETAP) (revised)
SLA = Saturated Area (square feet)
S.A. = Saturated Landscape Area (Square Feet)
CALCULATE MAWA

1.9 MAWA (MAXIMUM APPLIED WATER ALLOWANCE) (rev. 6/94/1)
MAWA CALCULATIONS
AREA DESCRIPTION LOCATION ETO COMVERSION FACTOR GROSS IRRIGATION AREA ADJUSTMENT S.A. MAWA INSTANTANEOUS MAWA NET MAWA

Table with 8 columns: AREA DESCRIPTION, LOCATION, ETO, COMVERSION FACTOR, GROSS IRRIGATION AREA, ADJUSTMENT, S.A. MAWA, INSTANTANEOUS MAWA, NET MAWA. Rows include Foothill Road Agoura Hills (TOTAL) and various landscape areas like Mulch, Lawn, and Driveway.

ETU (ESTIMATED TOTAL WATER USED) (rev. 6/94/1)
TABLE WITH 10 COLUMNS: NAME, LANDSCAPE DESCRIPTION, SENSATION TYPE, LOCATION, ETO, COMVERSION FACTOR, IRRIGATION RATE, IRRIGATION PERIOD, EST. TOTAL MAWA, EST. TOTAL ETU. Rows include various landscape areas like Lawn, Lawn, and Lawn.

PART 2.0 - PRODUCTS
2.1 MATERIALS AND EQUIPMENT
A. Equipment shall be new, unused, as specified, and as shown on the drawings.
B. Trench backfill in planter areas shall be site soil, free of debris, lumps, and rocks larger than one inch.
C. Trench backfill in paved areas shall be clean angular sand and concrete slurry (CLSM or Type E).

2.2 PIPE AND FITTINGS
A. Plastic pipe and fittings shall be as manufactured by PACIFIC PLASTICS or equal.
B. All pipe shall bear the following markings: Manufacturer's name, nominal pipe size, schedule or class, pressure rating in PSI, NSF (National Sanitation Foundation), and the date of manufacture of the pipe or manufacturer's lot number.
C. Irrigation mainline shall be SCH 40 or CLASS B10 PVC.
D. Irrigation lateral line below grade shall be CLASS 200 PVC.
E. Irrigation lateral line above grade shall be SCHEDULE 40 PVC.
F. All solvent weld fittings shall be SCHEDULE 40 PVC.
G. All threaded plastic fittings shall be injection molded SCHEDULE 40 PVC, unless shown as MARLEX on the plans.

2.3 ELECTRICAL
A. Controller Enclosure shall be 3/16" (4.2mm) steel, LEMUR SAFEGUARD MODEL A or equal, with 115 VAC duplex receptacles, lamp adapter, lamp, and terminal strips.
B. Enclosure shown on the drawings as a "stainless steel enclosure" shall have the same requirements as a standard enclosure, but shall be made of stainless steel.
C. Backflow Enclosure shall be steel or stainless steel, BPOI GUARDSHACK 65-35.
D. All enclosures shall be locking type, mounted on a concrete pad. Contractor shall furnish locks and keys.
E. All enclosures, except stainless steel, shall be finished with two coats of exterior grade white enamel.

2.4 CONTROL WIRE
A. All controllers shall be equipped with a rain shut off device. HUNTER MINI-CLIK or equal.
B. Trenching and Backfilling
1. Bed pipe continuously and evenly on bottom of trench.
2. Snake pipe in trench from side to side of trench.
3. Provide minimum cover of 18 inches (0.5m) for main line.
4. Provide minimum cover of 12 inches (0.3m) for lateral lines.
5. Compact trench backfill to a density equal to adjacent undisturbed soil.

2.5 TRENCHING AND BACKFILLING
A. Bed pipe continuously and evenly on bottom of trench.
B. Snake pipe in trench from side to side of trench.
C. Provide minimum cover of 18 inches (0.5m) for main line.
D. Provide minimum cover of 12 inches (0.3m) for lateral lines.
E. Compact trench backfill to a density equal to adjacent undisturbed soil.

2.6 PIPE FITTINGS
A. The minimal use of teflon tape and/or plastic compatible pipe thread compound on plastic fittings is acceptable; excessive use is prohibited.
B. All plastic slip fittings shall be solvent welded per pipe manufacturer's recommendations.
C. Line Clearance
1. All irrigation pipe shall have a minimum clearance of 4 inches from other pipes, and 12 inches from lines of other trades.
2. Clearance between potable and reclaimed water lines shall be per the governing agency.

2.7 TRENCHING AND BACKFILLING
A. Bed pipe continuously and evenly on bottom of trench.
B. Snake pipe in trench from side to side of trench.
C. Provide minimum cover of 18 inches (0.5m) for main line.
D. Provide minimum cover of 12 inches (0.3m) for lateral lines.
E. Compact trench backfill to a density equal to adjacent undisturbed soil.

2.8 TRENCHING AND BACKFILLING
A. Bed pipe continuously and evenly on bottom of trench.
B. Snake pipe in trench from side to side of trench.
C. Provide minimum cover of 18 inches (0.5m) for main line.
D. Provide minimum cover of 12 inches (0.3m) for lateral lines.
E. Compact trench backfill to a density equal to adjacent undisturbed soil.

PART 3.0 - EXECUTION
3.1 SITE CONDITIONS
A. Install an automatic irrigation system as shown on the drawings.
B. The intent of the drawings is to show a complete operating irrigation system. Do not modify, install or allow to be installed irrigation work when site conditions differ from the drawings to such an extent that the design will not work as intended.
C. Contact the LARG immediately upon discovery of such conditions. The contractor has the authority and duty to make minor adjustments in the irrigation work in order to complete a properly operating irrigation system.

3.2 IRRIGATION SYSTEM INSTALLATION
A. Points of connection
1. Connect to water supply as shown on the drawings. Coordinate installation of irrigation water meters(s) with serving utility. Verify water pressure at point of connection before starting other irrigation work. Notify LARG immediately if pressure is not as shown on the plans.
2. Install a backflow preventer as required by local code or as shown on the drawings.

3.3 ELECTRICAL SERVICE INSTALLATION
A. Electrical meter pedestal as shown on the drawings. Coordinate installation of meter and connection to 120VAC electrical service with the serving utility. Install 1" (25mm) electrical conduit and conductors from electric meter pedestal to irrigation controller cabinet. Install 1" (25mm) electrical conduit from electric meter pedestal to nearest available electrical service panel.
B. Electrical service installation IS NOT shown on the plans. The Owner will provide 120VAC power. Install 1" (25mm) electrical conduit and conductors from owner's electrical hookup point to irrigation controller.

3.4 TRENCHING AND BACKFILLING
A. Bed pipe continuously and evenly on bottom of trench.
B. Snake pipe in trench from side to side of trench.
C. Provide minimum cover of 18 inches (0.5m) for main line.
D. Provide minimum cover of 12 inches (0.3m) for lateral lines.
E. Compact trench backfill to a density equal to adjacent undisturbed soil.

3.5 TRENCHING AND BACKFILLING
A. Bed pipe continuously and evenly on bottom of trench.
B. Snake pipe in trench from side to side of trench.
C. Provide minimum cover of 18 inches (0.5m) for main line.
D. Provide minimum cover of 12 inches (0.3m) for lateral lines.
E. Compact trench backfill to a density equal to adjacent undisturbed soil.

3.6 TRENCHING AND BACKFILLING
A. Bed pipe continuously and evenly on bottom of trench.
B. Snake pipe in trench from side to side of trench.
C. Provide minimum cover of 18 inches (0.5m) for main line.
D. Provide minimum cover of 12 inches (0.3m) for lateral lines.
E. Compact trench backfill to a density equal to adjacent undisturbed soil.

3.7 TRENCHING AND BACKFILLING
A. Bed pipe continuously and evenly on bottom of trench.
B. Snake pipe in trench from side to side of trench.
C. Provide minimum cover of 18 inches (0.5m) for main line.
D. Provide minimum cover of 12 inches (0.3m) for lateral lines.
E. Compact trench backfill to a density equal to adjacent undisturbed soil.

3.8 TRENCHING AND BACKFILLING
A. Bed pipe continuously and evenly on bottom of trench.
B. Snake pipe in trench from side to side of trench.
C. Provide minimum cover of 18 inches (0.5m) for main line.
D. Provide minimum cover of 12 inches (0.3m) for lateral lines.
E. Compact trench backfill to a density equal to adjacent undisturbed soil.

3.9 TRENCHING AND BACKFILLING
A. Bed pipe continuously and evenly on bottom of trench.
B. Snake pipe in trench from side to side of trench.
C. Provide minimum cover of 18 inches (0.5m) for main line.
D. Provide minimum cover of 12 inches (0.3m) for lateral lines.
E. Compact trench backfill to a density equal to adjacent undisturbed soil.

F. Valve Boxes
1. Valve box lids shall have the following inscriptions: Remote control valve - "RCV" and valve station number. Gate, ball, or butterfly valve - "GV" and size of line. Quick coupler valve - "QCV".
2. Flush valve - "FV" and the valve station number.
3. Bronze plastic valve box lids with 2" (50mm) tall letters, 1/8" (3mm) deep minimum.
4. Bronze metal valve box lids with 2" (50mm) tall letters, 1/8" (3mm) deep minimum.

3.5 GUARANTEE
A. Guarantee the entire irrigation system for materials and workmanship, including setting of backfilled areas for a period of one (1) year following the date of final acceptance of the work.

3.6 GUARANTEE
A. Guarantee the entire irrigation system for materials and workmanship, including setting of backfilled areas for a period of one (1) year following the date of final acceptance of the work.

3.7 GUARANTEE
A. Guarantee the entire irrigation system for materials and workmanship, including setting of backfilled areas for a period of one (1) year following the date of final acceptance of the work.

3.8 GUARANTEE
A. Guarantee the entire irrigation system for materials and workmanship, including setting of backfilled areas for a period of one (1) year following the date of final acceptance of the work.

3.9 GUARANTEE
A. Guarantee the entire irrigation system for materials and workmanship, including setting of backfilled areas for a period of one (1) year following the date of final acceptance of the work.

3.10 GUARANTEE
A. Guarantee the entire irrigation system for materials and workmanship, including setting of backfilled areas for a period of one (1) year following the date of final acceptance of the work.

3.11 GUARANTEE
A. Guarantee the entire irrigation system for materials and workmanship, including setting of backfilled areas for a period of one (1) year following the date of final acceptance of the work.

3.12 GUARANTEE
A. Guarantee the entire irrigation system for materials and workmanship, including setting of backfilled areas for a period of one (1) year following the date of final acceptance of the work.

JOB NO: 18-110
CURRENT DATE: MAR 21 2017
LANDSCAPE ARCHITECT
CURTIS P. SILLARS
1143 East Main Street
Ventura, CA 93001
mmadocdesign.com

PROJECT TITLE
AGOURA HOUSE

1155 CAPRIANO AVE. SUITE 118
WESTPHALEN, CALIFORNIA 91385
TEL: 626-441-1278
WWW.MMADOCDESIGN.COM

PROJECT NO.
01-1994-01-0004

PROJECT LOCATION
1155 CAPRIANO AVE. SUITE 118
WESTPHALEN, CALIFORNIA 91385
TEL: 626-441-1278
WWW.MMADOCDESIGN.COM

PROJECT NO.
01-1994-01-0004

PROJECT NO.
01-1994-01-0004

PROJECT NO.
01-1994-01-0004

PROJECT NO.
01-1994-01-0004

PROJECT NO.
01-1994-01-0004

PROJECT NO.
01-1994-01-0004

PROJECT NO.
01-1994-01-0004

PROJECT NO.
01-1994-01-0004

PROJECT NO.
01-1994-01-0004

PROJECT NO.
01-1994-01-0004

PROJECT NO.
01-1994-01-0004

PROJECT NO.
01-1994-01-0004

PROJECT NO.
01-1994-01-0004

PROJECT NO.
01-1994-01-0004

PROJECT NO.
01-1994-01-0004

PROJECT NO.
01-1994-01-0004

PROJECT NO.
01-1994-01-0004

PROJECT NO.
01-1994-01-0004

PROJECT NO.
01-1994-01-0004

PROJECT NO.
01-1994-01-0004

PROJECT NO.
01-1994-01-0004

PROJECT NO.
01-1994-01-0004

PROJECT NO.
01-1994-01-0004

PROJECT NO.
01-1994-01-0004

PROJECT NO.
01-1994-01-0004

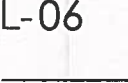
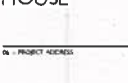

PROJECT NO.
01-1994-01-0004

L-06



SURVEYOR'S STATEMENT
 THIS MAP CORRECTLY REPRESENTS A TOPOGRAPHIC SURVEY MADE BY ME OR UNDER MY DIRECTION IN CONFORMANCE WITH LOCALLY ACCEPTED STANDARDS AND PRACTICES ON 12 FEBRUARY 2016.

AREA
 43,512.16 SQUARE FEET, 1.00 ACRES

AVERAGE NATURAL SLOPE
 40.82

- NOTES**
- NO ATTEMPT HAS BEEN MADE AS A PART OF THIS TOPOGRAPHIC SURVEY TO OBTAIN OR SHOW DATA CONCERNING EXISTING DEE, SEPTA, CONDUIT, CAPACITY, OR LOCATION OF ANY UTILITY OR MUNICIPAL PUBLIC SERVICE FACILITY, EXCEPT AS MAY BE SHOWN HEREON. FOR INFORMATION REGARDING THESE UTILITIES OR FACILITIES, CONTACT THE APPROPRIATE AGENCY.
 - EXCEPT AS SPECIFICALLY STATED OR SHOWN ON THIS PLAN, THIS TOPOGRAPHIC SURVEY DOES NOT purPORT TO REFLECT ANY OF THE FOLLOWING WHICH MAY BE APPLICABLE TO THE SUBJECT REAL ESTATE: EASEMENTS, EJECTA, TRAIL RIGHTS, EASEMENTS THAT WERE VISIBLE AT THE TIME OF MAKING THIS SURVEY, NEIGHBORING TRACTS, RESTRICTIONS CONCERNING ZONING OR OTHER LAND USE REGULATIONS, AND ANY OTHER LAND USE REGULATIONS, AND ANY OTHER FACTS THAT AN ACCURATE AND CURRENT TITLE SEARCH MAY DISCLOSE.
 - THE BOUNDARY SHOWN HEREON IS RECORD INFORMATION BASED UPON A BEST FIT OF FOUND PROPERTY CORNERS AS SHOWN HEREON.

LEGEND

| | |
|------|------------------|
| A.C. | ASPHALT CONCRETE |
| CL | CEMENTLINE |
| CONC | CONCRETE |
| FO | FOUND |
| FL | FLOWLINE |
| FS | FINISHED SURFACE |
| G | GROUND |
| IP | IRON PIPE |
| OH | OVERHEAD WIRES |
| PL | PROPERTY LINE |
| SM | SEWER MANHOLE |
| WM | WATER METER |

Slopes Table

| Number | Minimum Slope | Maximum Slope | Color | Area (sq. ft.) | % of Lot |
|----------------|---------------|---------------|------------------|-----------------|-------------|
| 1 | 0% | 15% | [Lightest Green] | 0 | 0 |
| 2 | 16% | 20% | [Light Green] | 4137.31 | 9.51 |
| 3 | 21% | 25% | [Medium Green] | 7854.61 | 17.80 |
| 4 | 26% | 30% | [Dark Green] | 3204.63 | 7.36 |
| 5 | 31% | 35% | [Darkest Green] | 504.35 | 1.16 |
| 6 | 36% | 4000.00% | [Brown] | 28007.06 | 64.37 |
| Totals: | | | | 43512.16 | 100% |

BENCHMARK
 BENCH MARK: Y 11283 (COUNTY OF L.A. MAUNO QUAD)
 20' W BY TAG IN NE CORN OF DRIVE TO HSE #5703 TOWN PL. AT NW COR. IN 3RD N/20 S. FOOTHILL DR.
 ELEVATION: 877.108 (MAY 08 2008)

Prepared by
AZIMUTH GROUP
 8891 CLEMONS STREET
 VENTURA, CA 93003 (805) 788-4947



TOPOGRAPHIC SURVEY
24825 FOOTHILL DRIVE
(VACANT LAND)
AGOURA HILLS, CALIFORNIA

