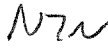

REPORT TO CITY COUNCIL

DATE: SEPTEMBER 27, 2017
TO: HONORABLE MAYOR AND MEMBERS OF THE CITY COUNCIL
FROM: GREG RAMIREZ, CITY MANAGER 
BY: NICK NEWKIRK, RECREATION SUPERVISOR 
SUBJECT: AGREEMENT FOR CONTRACTOR SERVICES FOR REPLACEMENT OF CHUMASH PARK AMMENITIES

Chumash Park is not only the biggest in size, but also the most used of the City's six local parks. A variety of events and uses are held in the park, including: four Concerts in the Park every summer, the annual Community Service Days in May, along with the several sports groups that use not only the softball field, but also the large open area. Chumash Park is also a popular place for moms to bring their children to play on the playground. Over the years, the high use of this park has caused the park's amenities (trash cans, picnic tables, etc.) to require replacement.

The Department of Community Services budgeted for the replacement of the park amenities at Chumash Park for the fiscal year 2016-2017. The lack of enough trash cans, along with the fact that there were no recycling centers, and the picnic tables were old and falling apart, lead the department to request money for the replacement. The replacement will include nine (9) trash cans, six (6) picnic tables, and adding four (4) new recycling centers, all of which will be strategically placed throughout the park, based on public use.

Staff researched several options and several companies that would be able to produce the site amenities that would match with not only the existing products, but also could match with future projects as well, in the hope of having a uniform look throughout the City. There was also grant money available to spend if there was a recycling component, so staff looked for not only recycling stations, but also products made from recycled material. The Department has been working with Dave Bang and Associates to order and install these amenities within fiscal year 2017-2018.

Staff is requesting to enter into a contract with Dave Bang and Associates that will conclude on December 31, 2017, with an amount not to exceed \$30,000.

RECOMMENDATION

Staff respectfully recommends the City Council:

1. Approve the Agreement for Contractor Services with Dave Bang and Associates
2. Authorize the Mayor to sign the agreement on behalf of the City Council.

Attachment: Dave Bang and Associates - Agreement for Contractor Services

**AGREEMENT FOR CONTRACTOR SERVICES
WITH THE CITY OF AGOURA HILLS**

NAME OF CONTRACTOR: Dave Bang Associates, Inc.
RESPONSIBLE PRINCIPAL OF CONTRACTOR: Attn: GERALYN FREUND
CONTRACTOR'S ADDRESS: P.O. Box 1088
Tustin, CA 92781
CITY'S ADDRESS: City of Agoura Hills
30001 Ladyface Court
Agoura Hills, CA 91301
Attn: City Manager
PREPARED BY: Nick Newkirk
COMMENCEMENT DATE: September 30, 2017
TERMINATION DATE: December 31, 2017
CONSIDERATION: Contract Price
Not to Exceed: \$30,000.00/yr

ADDITIONAL SERVICES <i>(Describe Services, Amount, and Approval):</i> _____ _____ _____ _____
--

Date: _____ Amount: \$ _____ Authorized By: _____
(Not to Exceed 10% of Contract Price) City Manager

**AGREEMENT FOR CONTRACTOR SERVICES BETWEEN
THE CITY OF AGOURA HILLS AND DAVE BANG
ASSOCIATES, INC**

THIS AGREEMENT is made and effective as of September 1, 2017, between the City of Agoura Hills, a municipal corporation ("City") and Dave Bang Associates, INC. ("Contractor"). In consideration of the mutual covenants and conditions set forth herein, the parties agree as follows:

1. TERM

This Agreement shall commence on September 30, 2017, and shall remain and continue in effect until tasks described herein are completed, but in no event later than December 31, 2017, unless sooner terminated pursuant to the provisions of this Agreement.

2. SERVICES

Contractor shall perform the services and tasks described and set forth in Exhibit A, attached hereto and incorporated herein as though set forth in full. Contractor shall complete the tasks according to the schedule of performance which is also set forth in Exhibit A.

3. PERFORMANCE

In meeting its obligations under this Agreement, Contractor shall at all times faithfully and competently perform all tasks described herein in a manner satisfactory to CITY and consistent with that level of care and skill ordinarily exercised by members of the profession currently practicing in the same locality under similar conditions.

4. PREVAILING WAGES

A. Prevailing wages are required on all CITY agreements involving construction, design, and preconstruction phases of construction (including, but not limited to, inspection and land surveying work), and maintenance (except for janitorial or security guards) for work on CITY property.

B. Pursuant to the provisions of Section 1773 of the Labor Code of the State of California, the City Council has obtained the general prevailing rate of per diem wages and the general rate for holiday and overtime work in this locality for each craft, classification, or type of workman needed to execute by this Contractor from the Director of the Department of Industrial Relations. Copies may be obtained from the California Department of Industrial Relations Internet website at <http://www.dir.ca.gov>. Consultant shall provide a copy of prevailing wage rates to any staff or sub-contractor hired, and shall pay the adopted prevailing wage rates as a minimum. Contractor shall comply with the provisions of Sections 1773.8, 1775, 1776, 1777.5, 1777.6, and 1813 of the Labor Code. Pursuant to the provisions of 1775 of the Labor Code, Contractor shall forfeit to the City,

as a penalty, the sum of \$50.00 for each calendar day, or portion thereof, for each laborer, worker, or mechanic employed, paid less than the stipulated prevailing rates for any work done under this contract, by him or by any sub-contractor under him, in violation of the provisions of the Agreement..

5. PAYMENT

A. The City agrees to pay Contractor monthly, in accordance with the payment rates and terms and the schedule of payment as set forth in Exhibit B, Payment Rates and Schedule, attached hereto and incorporated herein by this reference as though set forth in full, based upon actual time spent on the above tasks. Any terms in Exhibit B other than the payment rates and schedule of payment are null and void. This amount shall not exceed Thirty Thousand Dollars and Zero Cents (\$30,000) ("Contract Price") for the initial Term of the Agreement unless additional payment is approved as provided in this Agreement.

B. Contractor shall not be compensated for any services rendered in connection with its performance of this Agreement which are in addition to those set forth herein, unless such additional services are authorized in advance and in writing by the City Manager. Contractor shall be compensated for any additional services in the amounts and in the manner as agreed to by the City Council and Contractor at the time City's written authorization is given to Contractor for the performance of said services.

C. Contractor shall submit invoices monthly for actual services performed. Invoices shall be submitted between the first and fifteenth business day of each month, for services provided in the previous month. Payment shall be made within thirty (30) days of receipt of each invoice as to all non-disputed fees. If the City disputes any of Contractor's fees, it shall give written notice to Contractor within thirty (30) days of receipt of an invoice of any disputed fees set forth on the invoice. For all reimbursements authorized by this Agreement, Contractor shall provide receipts on all reimbursable expenses in excess of Fifty Dollars (\$50) in such form as approved by the Director of Finance.

6. SUSPENSION OR TERMINATION OF AGREEMENT WITHOUT CAUSE

A. The City may at any time, for any reason, with or without cause, suspend or terminate this Agreement, or any portion hereof, by serving upon the Contractor at least ten (10) days prior written notice. Upon receipt of said notice, the Contractor shall immediately cease all work under this Agreement, unless the notice provides otherwise. If the City suspends or terminates a portion of this Agreement, such suspension or termination shall not make void or invalidate the remainder of this Agreement.

B. In the event this Agreement is terminated pursuant to this Section, the City shall pay to Contractor the actual value of the work performed up to the time of termination, ~~provided that the work performed is of value to the City.~~ Upon termination of the Agreement pursuant to this Section, the Contractor will submit an invoice to the City pursuant to Section entitled "PAYMENT" herein.

7. DEFAULT OF CONTRACTOR

A. The Contractor's ^{Material} failure to comply with the provisions of this Agreement shall constitute a default. In the event that Contractor is in default for cause under the terms of this Agreement, City shall have no obligation or duty to continue compensating Contractor for any work performed after the date of default and can terminate this Agreement immediately by written notice to the Contractor. If such failure by the Contractor to make progress in the performance of work hereunder arises out of causes beyond the Contractor's control, and without fault or negligence of the Contractor, it shall not be considered a default.

B. If the City Manager or his delegate determines that the Contractor is in default in the performance of any of the terms or conditions of this Agreement, it shall serve the Contractor with written notice of the default. The Contractor shall have ten (10) days after service upon it of said notice in which to cure the default by rendering a satisfactory performance. In the event that the Contractor fails to cure its default within such period of time, the City shall have the right, notwithstanding any other provision of this Agreement, to terminate this Agreement without further notice and without prejudice to any other remedy to which it may be entitled at law, in equity or under this Agreement."

8. OWNERSHIP OF DOCUMENTS

A. Contractor shall maintain complete and accurate records with respect to sales, costs, expenses, receipts and other such information required by City that relate to the performance of services under this Agreement. Contractor shall maintain adequate records of services provided in sufficient detail to permit an evaluation of services. All such records shall be maintained in accordance with generally accepted accounting principles and shall be clearly identified and readily accessible. Contractor shall provide free access to the representatives of City or its designees at reasonable times to such books and records, shall give City the right to examine and audit said books and records, shall permit City to make transcripts there from as necessary, and shall allow inspection of all work, data, documents, proceedings and activities related to this Agreement. Such records, together with supporting documents, shall be maintained for a period of three (3) years after receipt of final payment.

B. Upon completion of, or in the event of termination or suspension of this Agreement, all original documents, designs, drawings, maps, models, computer files containing data generated for the work, surveys, notes, and other documents prepared in the course of providing the services to be performed pursuant to this Agreement shall become the sole property of the City and may be used, reused or otherwise disposed of by the City without the permission of the Contractor. With respect to computer files containing data generated for the work, Contractor shall make available to the City, upon reasonable written request by the City, the necessary computer software and hardware for purposes of accessing, compiling, transferring and printing computer files.

9. INDEMNIFICATION

Contractor shall defend, indemnify, and hold the City, its officials, officers, employees, agents and independent Contractors serving in the role of City officials, and volunteers (collectively "Indemnitees") free and harmless from any and all claims, demands, causes of action, proceedings, costs, expenses, liabilities, losses, damages or injuries, in law or equity, to property or persons, including wrongful death (collectively "Claims"), in any manner arising out of or incident to any acts or omissions of Contractor, its officials, officers, employees, agents or sub-contractor in connection with the performance of this Agreement, including without limitation the payment of all consequential damages, attorneys' fees, and other related costs and expenses, except for such Claims arising out of the sole negligence or willful misconduct of the Indemnitees. With respect to any and all such Claims, Contractor shall defend Indemnitees at Contractor's own cost, expense, and risk and shall pay and satisfy any judgment, award, or decree that may be rendered against Indemnitees. Contractor shall reimburse Indemnitees for any and all legal expenses and costs incurred by each of them in connection therewith or in enforcing the indemnity herein provided. Contractor's obligation to indemnify shall not be restricted to insurance proceeds, if any, received by Contractor or Indemnitees. All duties of Contractor under this Section shall survive termination of this Agreement.

10. INSURANCE REQUIREMENTS

Prior to commencement of work, Contractor shall procure, provide, and maintain, at Contractor's own expense, for the duration of this Agreement, insurance against claims for injuries to persons or damages to property, which may arise from or in connection with the performance of the work hereunder by the Contractor, its agents, representatives, or employees.

A. Minimum Scope of Insurance. Coverage shall be at least as broad as:

1) Insurance Services Office Commercial General Liability form No. CG 00 01 11 85 or 88, or equivalent.

2) Insurance Services Office Business Auto Coverage form CA 00 01 06 92, or equivalent, covering Automobile Liability, code 1 (any auto). If the Contractor owns no automobiles, a non-owned auto endorsement to the General Liability policy described above is acceptable.

3) Worker's Compensation insurance as required by the State of California and Employer's Liability Insurance. If the Contractor has no employees while performing under this Agreement, worker's compensation insurance is not required, but Contractor shall execute a declaration that it has no employees.

B. Minimum Limits of Insurance. Contractor shall maintain limits no less than:

1) General Liability: \$1,000,000 per occurrence for bodily injury, personal injury and property damage, including without limitation, blanket contractual liability. If Commercial General Liability Insurance or other form with a general aggregate limit is used, either the general aggregate limit shall apply separately to this project/location or the general aggregate limit shall be twice the required occurrence limit.

2) Automobile Liability: \$1,000,000 per accident for bodily injury and property damage for all activities of the Contractor arising out of or in connection with work to be performed under this Agreement, including coverage for any owned, hired, non-owned or rental vehicles.

3) Worker's Compensation as required by the State of California; Employer's Liability: One million dollars (\$1,000,000) per accident for bodily injury or disease.

C. Deductibles and Self-Insured Retentions. Any deductibles or self-insured retentions must be declared to and approved by the City Manager. At the option of the City Manager, either the insurer shall reduce or eliminate such deductibles or self-insured retentions as respects the City, its officers, officials, employees and volunteers; or the Contractor shall procure a bond guaranteeing payment of losses and related investigations, claim administration and defense expenses.

D. Requirements Not Limiting. Requirements of specific coverage features or limits contained in this Section are not intended as a limitation on coverage, limits or other requirements, or a waiver of any coverage normally provided by any insurance. Specific reference to a given coverage feature is for purposes of clarification only as it pertains to a given issue and is not intended by any party or insured to be all inclusive, or to the exclusion of other coverage, or a waiver of any type. If the Vendor maintains higher limits than the minimums shown above, the Agency requires and shall be entitled to coverage for the higher limits maintained by the Vendor. Any available insurance proceeds in excess of the specified minimum limits of insurance and coverage shall be available to the Agency.

E. Other Insurance Provisions. The general liability and automobile liability policies are to contain, or be endorsed to contain, the following provisions:

1) The City, its officers, officials, employees and volunteers are to be covered and named as additional insureds in respect to: liability arising out of activities performed by or on behalf of the Contractor; products and completed operations of the Contractor; premises owned, occupied or used by the Contractor; or automobiles owned, leased, hired or borrowed by the Contractor. The coverage shall contain no special limitations on the scope of protection afforded to the City, its officers, officials, employees or volunteers.

2) For any claims related to this project, the Contractor's insurance coverage shall be primary insurance as respects the City, its officers, officials, employees and volunteers. Any insurance or self-insured maintained by the City, its officers, officials, employees or volunteers shall be excess of the Contractor's insurance and shall not contribute with it.

3) Any failure to comply with reporting or other provisions of the policies including breaches of warranties shall not affect coverage provided to the City, its officers, officials, employees or volunteers.

4) The Contractor's insurance shall apply separately to each insured against whom claim is made or suit is brought, except with respect to the limits of the insurer's liability.

5) Each insurance policy required by this clause shall be endorsed to state that coverage shall not be suspended, voided, canceled by either party, reduced in coverage or in limits except after thirty (30) days' prior written notice has been given to the City. Contractor agrees to oblige its insurance agent or broker and insurers to provide City with a thirty (30) day notice of cancellation (except for nonpayment for which a ten (10) day notice is required) or nonrenewal of coverage for each required coverage.

F. Acceptability of Insurers. Insurance is to be placed with insurers with a current A.M. Best's rating of no less than A:VII, unless otherwise acceptable to the City. Self insurance shall not be considered to comply with these insurance requirements.

G. Verification of Coverage. Contractor shall furnish the City with original endorsements, specifically naming the City of Agoura Hills, its officers, officials, employees and volunteers as additional insured, effecting coverage required by this clause. The endorsements are to be signed by a person authorized by that insurer to bind coverage on its behalf. The endorsements are to be on forms acceptable to the City. Insurance certificates and endorsements must be received and approved by City's Risk Manager prior to commencement of performance. Current insurance certificates and endorsements shall be kept on file with the City at all times during the term of this agreement. City reserves the right to require complete, certified copies of all required insurance policies, at any time.

H. Mailing Instructions. Insurance documents shall be mailed with the signed Agreement to the attention of the staff person indicated on the cover sheet of this Agreement, to the City of Agoura Hills, 30001 Ladyface Court, Agoura Hills, CA 91301. Executed Agreement(s) cannot be released nor may any work commence on a project until the signed Agreement and appropriate insurance documents are on file with the City Clerk.

11. INDEPENDENT CONSULTANT

A. Contractor is and shall at all times remain as to the City a wholly independent Contractor. The personnel performing the services under this Agreement on behalf of Contractor shall at all times be under Contractor's exclusive direction and control. Neither City nor any of its officers, employees, agents, or volunteers shall have control over the conduct of Contractor or any of Contractor's officers, employees, or agents except as set forth in this Agreement. Contractor shall not at any time or in any manner represent that it or any of its officers, employees or agents are in any manner officers, employees or agents of the City. Contractor shall not incur or have the power to incur any debt, obligation or liability whatever against City, or bind City in any manner.

B. No employee benefits shall be available to Contractor in connection with the performance of this Agreement. Except for the fees paid to Contractor as provided in the Agreement, City shall not pay salaries, wages, or other compensation to Contractor for performing services hereunder for City. City shall not be liable for compensation or indemnification to Contractor for injury or sickness arising out of performing services hereunder.

12. LEGAL RESPONSIBILITIES

The Contractor shall keep itself informed of all local, State and Federal ordinances, laws and regulations which in any manner affect those employed by it or in any way affect the performance of its service pursuant to this Agreement. The Contractor shall at all times observe and comply with all such ordinances, laws and regulations. The City, and its officers and employees, shall not be liable at law or in equity occasioned by failure of the Contractor to comply with this section.

13. RELEASE OF INFORMATION

A. All information gained by Contractor in performance of this Agreement shall be considered confidential and shall not be released by Contractor without City's prior written authorization. Contractor, its officers, employees, agents or sub-contractors, shall not without written authorization from the City Manager or unless requested by the City Attorney, voluntarily provide declarations, letters of support, testimony at depositions, response to interrogatories or other information concerning the work performed under this Agreement or relating to any project or property located within the City. Response to a subpoena or court order shall not be considered "voluntary" provided Contractor gives City notice of such court order or subpoena.

B. Contractor shall promptly notify City should Contractor, its officers, employees, agents or sub-contractor be served with any summons, complaint, subpoena, notice of deposition, request for documents, interrogatories, request for admissions or other discovery request, court order or subpoena from any party regarding this Agreement and the work performed there under or with respect to any project or property located within the City. City retains the right, but has no obligation, to represent Contractor and/or be present at any deposition, hearing or similar proceeding. Contractor agrees to cooperate fully with City and to provide City with the opportunity to review any response to discovery requests provided by Contractor. However, City's right to review any such response does not imply or mean the right by City to control, direct, or rewrite said response.

14. NOTICES

Any notices which either party may desire to give to the other party under this Agreement must be in writing and may be given either by: (i) personal service, (ii) delivery by a reputable document delivery service, such as but not limited to, Federal Express, that provides a receipt showing date and time of delivery, or (iii) mailing in the United States Mail, certified mail, postage prepaid, return receipt requested, addressed to the address of the party as set forth below or at any other address as that party may later designate by Notice. Notice shall be effective upon delivery to the addresses

specified below or on the third business day following deposit with the document delivery service or United States Mail as provided above.

To City: City of Agoura Hills
30001 Ladyface Court
Agoura Hills, California 91301
Attention: City Manager

To Contractor: **Dave Bang Associates, Inc.**
P.O. Box 1088
Tustin, CA 92781
Attention: Geralyn Freund

15. ASSIGNMENT

The Contractor shall not assign the performance of this Agreement, nor any part thereof, nor any monies due hereunder, without prior written consent of the City. Upon termination of this Agreement, Contractor's sole compensation shall be payment for actual services performed up to, and including, the date of termination or as may be otherwise agreed to in writing between the City Council and the Contractor.

16. LICENSES

At all times during the term of this Agreement, Contractor shall have in full force and effect, all licenses required of it by law for the performance of the services described in this Agreement.

17. GOVERNING LAW

The City and Contractor understand and agree that the laws of the State of California shall govern the rights, obligations, duties and liabilities of the parties to this Agreement and also govern the interpretation of this Agreement. Any litigation concerning this Agreement shall take place in the municipal, superior, or federal district court with geographic jurisdiction over the City of Agoura Hills. In the event such litigation is filed by one party against the other to enforce its rights under this Agreement, the prevailing party, as determined by the Court's judgment, shall be entitled to reasonable attorney fees and litigation expenses for the relief granted.

18. PROHIBITED INTEREST

No officer, or employee of the City of Agoura Hills shall have any financial interest, direct or indirect, in this Agreement, the proceeds thereof, the Contractor, or Contractor's sub-contractors for this project, during his/her tenure or for one year thereafter. The Contractor hereby warrants and represents to the City that no officer or employee of the City of Agoura Hills has any interest, whether contractual, non-contractual, financial or otherwise, in this transaction, or in the business of the Contractor or Contractor's sub-contractors on this project. Contractor further agrees to notify the City in the event any such interest is discovered whether or not such interest is prohibited by law or this Agreement.

19. ENTIRE AGREEMENT

This Agreement contains the entire understanding between the parties relating to the obligations of the parties described in this Agreement. All prior or contemporaneous agreements, understandings, representations and statements, oral or written, are merged into this Agreement and shall be of no further force or effect. Each party is entering into this Agreement based solely upon the representations set forth herein and upon each party's own independent investigation of any and all facts such party deems material.

20. AUTHORITY TO EXECUTE THIS AGREEMENT

The person or persons executing this Agreement on behalf of Contractor warrants and represents that he or she has the authority to execute this Agreement on behalf of the Contractor and has the authority to bind Contractor to the performance of its obligations hereunder.

IN WITNESS WHEREOF, the parties hereto have caused this Agreement to be executed the day and year first above written.

CITY OF AGOURA HILLS

Denis Weber,
Mayor

ATTEST:

Kimberly M. Rodrigues, MMC
City Clerk
Date Approved by City Council: _____

APPROVED AS TO FORM:

Candice K. Lee,
City Attorney

CONTRACTOR

Dave Bang Associates, Inc.
P.O. Box 1088
Geraldyn Freund
Telephone: 800-669-2585
Facsimile: 800-729-2483

By: X 

Name: John Wormell

Title: President

By: X 

Name: Brad Enclin

Title: VP / CFO

[Signatures of Two Corporate Officers Required]

EXHIBIT A

TASKS TO BE PERFORMED

The specific elements (scope of work) of this service include:

Dave Bang will deliver, assemble and install at Chumash Park, under the City's supervision:

6 picnic tables, 9 trash receptacles and four recycling stations (each with one container for "recycle", "Cans" and "Paper").

(See attached order forms for specific order)

EXHIBIT B

PAYMENT RATES AND SCHEDULE

Payment will be sent upon completion and will not exceed \$30,000.00.

P.O. Box 1088, Tustin, CA 92781
 P: (800) 669-2585
 F: (800) 729-2483
 www.davebang.com LIC # 795052



Quotation
 CA 132098 R2

To **City of Agoura Hills**
Attn: Nick Newkirk
29900 Ladyface Court
Agoura Hills, Ca 91301

Quotation Date 8/17/2017	Salesperson Cathy Cook
------------------------------------	----------------------------------

Terms Net 30

*Chumash Park
 Recycle Center Installation*

Estimated Shipping Date 4-6 Weeks	Shipped Via Truck	F.O.B. Agoura Hills
---	-----------------------------	-------------------------------

Quantity	Description	Unit Price	Total Extended
1	Installation of: -(4) Wabash # LR110N, Recycle Center Inground Post System -(12) Wabash # LR300S, 32-Gallon Trash Receptacle, Slat Pattern, portable/surface mount -(8) Wabash # FT107N, Recycle Flat Top Lid, with no label and 5" diameter opening, outward slope -(4) Wabash # FT100N, Flat Top Lid, 8" diameter opening with inward slope -(4) Wabash # LB100N, "Recycle ONLY" Label -(4) Wabash # LB102N, "Cans ONLY" Label -(4) Wabash # LB103N, "Paper ONLY" Label -(12) Wabash # LR310N, 32-Gallon Rigid Plastic Liner * MUST BE INSTALLED AT THE SAME TIME AS CA QUOTE # 132003 R1 & 132736 * *Prevailing Wages INCLUDED	2,900.00	2,900.00

THANK YOU FOR THIS CHANCE TO QUOTE <small>DAVE BANG ASSOCIATES, INC OF CALIFORNIA IS PLEASED TO SUBMIT THE ABOVE QUOTATION FOR YOUR CONSIDERATION. SHOULD YOU PLACE AN ORDER, BE ASSURED IT WILL RECEIVE OUR PROMPT ATTENTION. THIS QUOTATION IS SUBJECT TO THE CONDITIONS OF OUR CREDIT APPLICATION, AND IS VALID FOR 30 DAYS. THEREAFTER IT IS SUBJECT TO CHANGE WITHOUT NOTICE. FAX OR EMAIL COPY DEEMED TO BE LEGAL EQUIVALENT OF ORIGINAL. ALL PAST DUE ACCOUNTS SUBJECT TO 1 1/2% MONTHLY FINANCE CHARGE. IN THE EVENT LEGAL ACTION IS REQUIRED TO EFFECT COLLECTION VENUE SHALL BE ORANGE, CA.</small>	Subtotal
	Tax (9.25%)
	TOTAL

By: Cathy Cook Accepted _____ Date _____

PLEASE SIGN AND RETURN ONE COPY WHEN ORDERING.

Thank You!

P.O. Box 1088, Tustin, CA 92781
 P: (800) 669-2585
 F: (800) 729-2483
 www.davebang.com LIC # 795052



Quotation
 CA 132098 R2

To **City of Agoura Hills**
Attn: Nick Newkirk
29900 Ladyface Court
Agoura Hills, Ca 91301

Quotation Date 8/17/2017	Salesperson Cathy Cook
------------------------------------	----------------------------------

Terms Net 30

*Chumash Park
 Recycle Center Installation*

Estimated Shipping Date 4-6 Weeks	Shipped Via Truck	F.O.B. Agoura Hills
---	-----------------------------	-------------------------------

Quantity	Description	Unit Price	Total Extended
	<p>*Site Prep / Excavation NOT included *ACCESS CLAUSE: Customer to provide 6' access for tractor. If adequate access is not provided additional charges may apply and repairs to landscape and irrigation may be required. Customer is responsible for any repairs to landscape if proper access is not provided. *ROCK CLAUSE: Pricing is based on normal soil conditions which would allow an auger on a tractor to dig footings. If rocks/boulders interfere with the progress of the excavation, additional fees may apply. *UTILITY CLAUSE: Installation to include marking of utilities by Dig Alert. Contractor will not be responsible for any damage to unmarked utilities, such as drainage, irrigation, live water lines, main low voltage lines, etc. Customers responsibility to provide locations of any utilities prior to commencement of work.</p>		

<p>THANK YOU FOR THIS CHANCE TO QUOTE</p> <p>DAVE BANG ASSOICATES, INC OF CALIFORNIA IS PLEASED TO SUBMIT THE ABOVE QUOTATION FOR YOUR CONSIDERATION. SHOULD YOU PLACE AN ORDER, BE ASSURED IT WILL RECEIVE OUR PROMPT ATTENTION. THIS QUOTATION IS SUBJECT TO THE CONDITIONS OF OUR CREDIT APPLICATION, AND IS VALID FOR 30 DAYS. THEREAFTER IT IS SUBJECT TO CHANGE WITHOUT NOTICE. FAX OR EMAIL COPY DEEMED TO BE LEGAL EQUIVALENT OF ORIGINAL. ALL PAST DUE ACCOUNTS SUBJECT TO 1 1/2% MONTHLY FINANCE CHARGE. IN THE EVENT LEGAL ACTION IS REQUIRED TO EFFECT COLLECTION VENUE SHALL BE ORANGE, CA.</p>	Subtotal	\$2,900.00
	Tax (9.25%)	\$0.00
	TOTAL	\$2,900.00

By: Cathy Cook Accepted _____ Date _____

PLEASE SIGN AND RETURN ONE COPY WHEN ORDERING.

Thank You!

P.O. Box 1088, Tustin, CA 92781
 P: (800) 669-2585
 F: (800) 729-2483
 www.davebang.com LIC # 795052



Quotation
 CA 132097 R2

To **City of Agoura Hills**
Attn: Nick Newkirk
29900 Ladyface Court
Agoura Hills, Ca 91301

Quotation Date 8/17/2017	Salesperson Cathy Cook
------------------------------------	----------------------------------

Terms Net 30 Piggyback Bid #15-11
--

*Chumash Park
 Recycle Centers*

Estimated Shipping Date 4-6 Weeks	Shipped Via Truck	F.O.B. Agoura Hills
---	-----------------------------	-------------------------------

Quantity	Description	Unit Price	Total Extended
4	Wabash # LR110N, Recycle Center Inground Post System Color: BROWN	191.00	764.00
12	Wabash # LR300S, 32-Gallon Trash Receptacle, Slat Pattern, portable/surface mount Color: BROWN	447.00	5,364.00
8	Wabash # FT107N, Recycle Flat Top Lid, with no label and 5" diameter opening, outward slope Color: BLACK	77.00	616.00
4	Wabash # FT100N, Flat Top Lid, 8" diameter opening with inward slope Color: BLACK	84.00	336.00
4	Wabash # LB100N, "Recycle ONLY" Label	26.00	104.00
4	Wabash # LB102N, "Cans ONLY" Label	26.00	104.00
4	Wabash # LB103N, "Paper ONLY" Label	26.00	104.00
12	Wabash # LR310N, 32-Gallon Rigid Plastic Liner	29.00	348.00
	Less Colton Joint USD Piggyback Bid Discount	-1,161.00	-1,161.00

THANK YOU FOR THIS CHANCE TO QUOTE

DAVE BANG ASSOICATES, INC OF CALIFORNIA IS PLEASED TO SUBMIT THE ABOVE QUOTATION FOR YOUR CONSIDERATION. SHOULD YOU PLACE AN ORDER, BE ASSURED IT WILL RECEIVE OUR PROMPT ATTENTION. THIS QUOTATION IS SUBJECT TO THE CONDITIONS OF OUR CREDIT APPLICATION, AND IS VALID FOR 30 DAYS. THEREAFTER IT IS SUBJECT TO CHANGE WITHOUT NOTICE. FAX OR EMAIL COPY DEEMED TO BE LEGAL EQUIVALENT OF ORIGINAL. ALL PAST DUE ACCOUNTS SUBJECT TO 1 1/2% MONTHLY FINANCE CHARGE. IN THE EVENT LEGAL ACTION IS REQUIRED TO EFFECT COLLECTION VENUE SHALL BE ORANGE, CA.

Subtotal
Tax (9.25%)
TOTAL

By: Cathy Cook Accepted _____ Date _____

PLEASE SIGN AND RETURN ONE COPY WHEN ORDERING.

Thank You!

P.O. Box 1088, Tustin, CA 92781
 P: (800) 669-2585
 F: (800) 729-2483
 www.davebang.com LIC # 795052



Quotation
 CA 132097 R2

To **City of Agoura Hills**
Attn: Nick Newkirk
29900 Ladyface Court
Agoura Hills, Ca 91301

Quotation Date 8/17/2017	Salesperson Cathy Cook
------------------------------------	----------------------------------

Terms Net 30 Piggyback Bid #15-11
--

*Chumash Park
 Recycle Centers*

Estimated Shipping Date 4-6 Weeks	Shipped Via Truck	F.O.B. Agoura Hills
---	-----------------------------	-------------------------------

Quantity	Description	Unit Price	Total Extended
	Subtotal		6,579.00
	Shipping	1,940.00	1,940.00
<p>*Assembly and Installation NOT Included *Shipped by Common Carrier - Will need 2-3 people to unload * MUST SHIP WITH CA 132731 and CA 131971 R1 FOR FREIGHT COSTS TO BE VALID *</p>			

<p>THANK YOU FOR THIS CHANCE TO QUOTE</p> <p>DAVE BANG ASSOICATES, INC OF CALIFORNIA IS PLEASED TO SUBMIT THE ABOVE QUOTATION FOR YOUR CONSIDERATION. SHOULD YOU PLACE AN ORDER, BE ASSURED IT WILL RECEIVE OUR PROMPT ATTENTION. THIS QUOTATION IS SUBJECT TO THE CONDITIONS OF OUR CREDIT APPLICATION, AND IS VALID FOR 30 DAYS. THEREAFTER IT IS SUBJECT TO CHANGE WITHOUT NOTICE. FAX OR EMAIL COPY DEEMED TO BE LEGAL EQUIVALENT OF ORIGINAL. ALL PAST DUE ACCOUNTS SUBJECT TO 1 1/2% MONTHLY FINANCE CHARGE. IN THE EVENT LEGAL ACTION IS REQUIRED TO EFFECT COLLECTION VENUE SHALL BE ORANGE, CA.</p>	Subtotal	\$8,519.00
	Tax (9.25%)	\$608.56
	TOTAL	\$9,127.56

By: Cathy Cook Accepted _____ Date _____

PLEASE SIGN AND RETURN ONE COPY WHEN ORDERING.

Thank You!

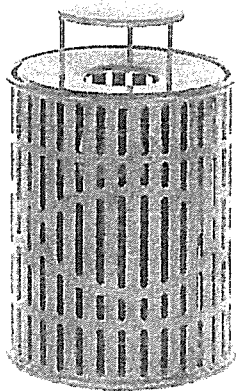

\$339
LR300(R) with SB100
(Sold separately)

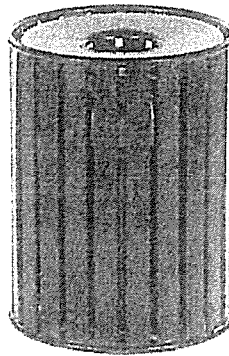

\$447
LR300(S) with FT100
(Sold separately)

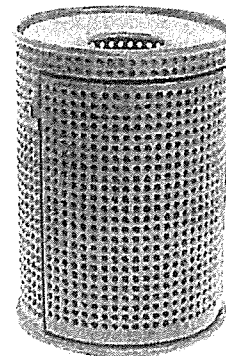

\$487
LR305(P) with FT100
(Sold separately)

STANDARD RECEPTACLES

Options: Liners, lids and mounting posts available separately for use on any size. See lids on page 77.

Perforated and rib pattern 32-Gallon receptacles available with side door option.

Patterns: Diamond, perforated, rib or slat

MODEL	DESCRIPTION	DIAMOND (D)		PERFORATED (P)	
		WEIGHT	PRICE	WEIGHT	PRICE
LR200	22-Gallon receptacle	57 lb.	\$216.00	76 lb.	\$291.00
LR300	32-Gallon receptacle	67 lb.	\$240.00	85 lb.	\$339.00
LR305	32-Gallon receptacle with side door	Not Available		111 lb.	\$487.00
		RIB (R)		SLAT (S)	
		WEIGHT	PRICE	WEIGHT	PRICE

LR200	22-Gallon receptacle	88 lb.	\$291.00	161 lb.	\$397.00
LR300	32-Gallon receptacle	106 lb.	\$339.00	175 lb.	\$447.00
LR305	32-Gallon receptacle with side door	111 lb.	\$487.00		Not Available

MODEL	ACCESSORIES FOR ITEMS ABOVE (PATTERN OPTIONS - NOT AVAILABLE)	WEIGHT	PRICE
LR210	22-Gallon receptacle liner	4 lb.	\$26.00
LR310	32-Gallon receptacle liner	7 lb.	\$29.00
LR100	In-ground post package	12 lb.	\$59.00
LR105	Surface-mount post package	12 lb.	\$59.00

ACCESSORIES CONTINUED ▶

\$186
FT117

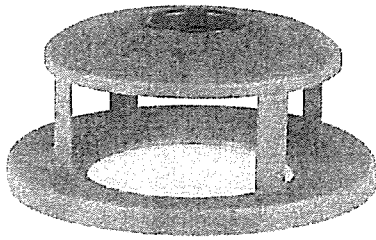

\$137
FT116

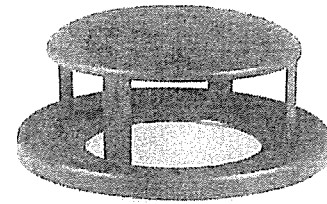

\$84
FT105



\$109
AL100



RECEPTACLE LIDS

Choose from several lid options for use on all Wabash Valley receptacles. All styles will fit any of our Standard, Flare-top or Tapered receptacles. (We offer a Flat-top lid specifically for our 55-Gallon receptacle, as other lid options won't fit.) All lids come standard with heavy-duty stainless-steel aircraft cables to secure them to the receptacles.

Choose your lid and style:

Powder-coated Flat-top lids in inward or outward slope.

Bonnet lids in solid, ashtray or serving tray options.

Cast ash/trash lid.

Foam-molded plastic dome-top lid.

Flat-top recycle lid labeled "Recycle Only" with 5" diameter hole opening.

Dome-top recycle lid labeled "Recycle Only" in black with 4" diameter hole opening.

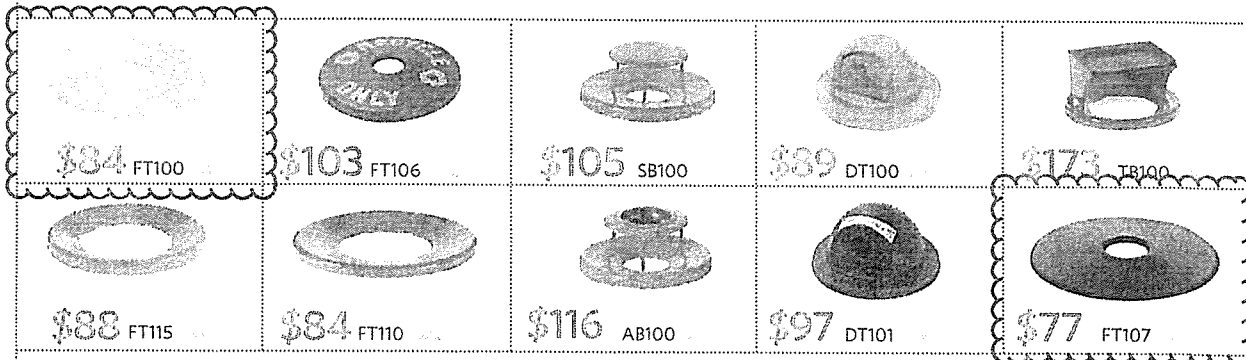

MODEL	DESCRIPTION	WEIGHT	PRICE
FT100	Flat-top lid with 8"-diameter opening - Inward slope	9 lb.	\$84.00
FT105	Flat-top lid with 8"-diameter opening - Outward slope	7 lb.	\$84.00
FT106	Flat-top recycle lid with 5"-diameter opening - Outward slope	7 lb.	\$103.00
FT107	Recycle Flat-top lid - No label with 5"-diameter opening - Outward slope	7 lb.	\$77.00
FT110	Flat-top lid with 14"-diameter opening	8 lb.	\$84.00
FT115	Flat-top lid for 55-Gallon receptacle	12 lb.	\$88.00
FT116	Flat-top with solid bonnet for 55-Gallon receptacle	16 lb.	\$137.00
FT117	Flat-top with ash bonnet for 55-Gallon receptacle	16 lb.	\$186.00
AL100	Ash/Trash lid	13 lb.	\$109.00
DT100	Dome-top lid	12 lb.	\$89.00
DT101	Dome-top recycle lid	7 lb.	\$97.00
SB100	Flat-top with solid bonnet - Inward slope	16 lb.	\$105.00
SB105	Flat-top with solid bonnet - Outward slope	14 lb.	\$105.00
AB100	Flat-top with ashtray bonnet - Inward slope	16 lb.	\$116.00
AB105	Flat-top with ashtray bonnet - Outward slope	14 lb.	\$116.00
TB100	Flat-top with tray bonnet	21 lb.	\$173.00

This lid can be ordered for use on any 32-Gallon receptacle purchased prior to 2002.

MODEL	DESCRIPTION	WEIGHT	PRICE
DT200	Dome-top lid - (black color only)	10 lb.	\$96.00



WABASH VALLEY ACCESSORIES (CONT.)

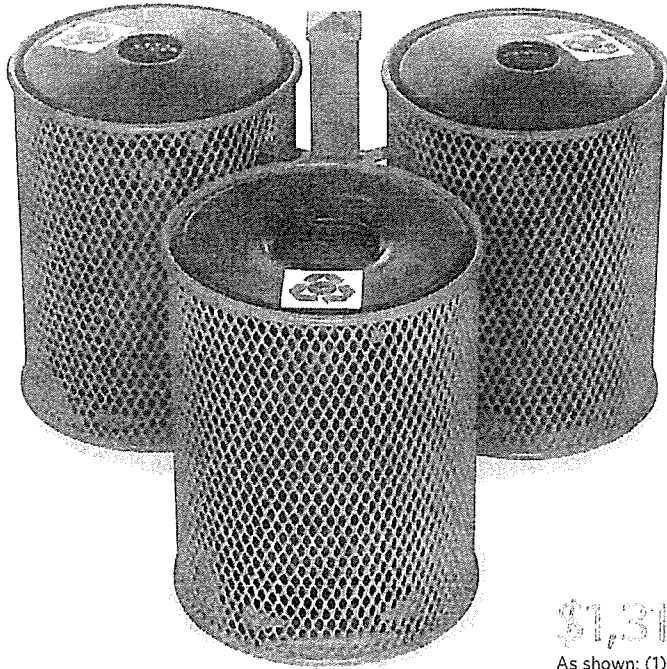

\$1,314

As shown: (1) LR112;
(3) LR300D; (3) LR310;
(2) FT107; (1) FT100;
(1) LB101; (1) LB102;
(1) LB103

RECYCLE STATION

Our Recycle Station components are all sold separately, allowing you flexibility in look and function.

How To Order:

1. Select a post system (LR110 or LR112)
2. Select (3) 32-Gallon receptacles (found on pages 74-75, all options except tapered LR350 can be used)
3. Select (3) lid options. The following lid options can be used: FT100, FT105, FT106, FT107, DT100, DT101, SB100 or SB105.
4. Select (3) liners (LR310 found on page 75)
5. Select recycle labels. Some of our lid options already come with labels (e.g., FT106) while others can be retrofitted with the LB100, LB101, LB102 or LB103 labels (e.g., FT107).



\$26 LB100

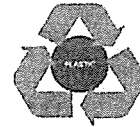

\$26 LB101

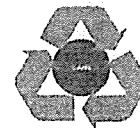

\$26 LB102

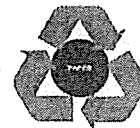

\$26 LB103

MODEL	DESCRIPTION	WEIGHT	PRICE
LR110	Recycle Center In-ground post system	38 lb.	\$191.00
LR112	Recycle Center Surface-mount post system	33 lb.	\$191.00
LB100	"Recycle Only" label	1 lb.	\$26.00
LB101	"Plastic Only" label	1 lb.	\$26.00
LB102	"Cans Only" label	1 lb.	\$26.00
LB103	"Paper Only" label	1 lb.	\$26.00

P.O. Box 1088, Tustin, CA 92781
 P: (800) 669-2585
 F: (800) 729-2483
 www.davebang.com LIC # 795052



Quotation
 CA 132736

To City of Agoura Hills
Attn: Nick Newkirk
29900 Ladyface Court
Agoura Hills, Ca 91301

Quotation Date 8/17/2017	Salesperson Cathy Cook
------------------------------------	----------------------------------

Terms Net 30

*Chumash Park
 Trash Receptacles Installation*

Estimated Shipping Date 4-6 Weeks	Shipped Via Truck	F.O.B. Agoura Hills
--------------------------------------	----------------------	------------------------

Quantity	Description	Unit Price	Total Extended
1	Assembly & Installation of: -(9) Wabash # LR300S, 32-Gallon Trash Receptacle, Slat Pattern, portable/surface mount Color: BROWN -(9) Wabash # FT100N, Flat Top Lid, 8" diameter opening with inward slope Color: BLACK -(9) Wabash # LR310N, 32-Gallon Rigid Plastic Liner -(9) Wabash # LR100N, Inground Post Package Color: BROWN * MUST BE INSTALLED WITH CA 132098 R2 and CA 132003 R1 COSTS TO BE VALID * *Prevailing Wages INCLUDED *Site Prep / Excavation NOT included	2,000.00	2,000.00

THANK YOU FOR THIS CHANCE TO QUOTE <small>DAVE BANG ASSOICATES, INC OF CALIFORNIA IS PLEASED TO SUBMIT THE ABOVE QUOTATION FOR YOUR CONSIDERATION. SHOULD YOU PLACE AN ORDER, BE ASSURED IT WILL RECEIVE OUR PROMPT ATTENTION. THIS QUOTATION IS SUBJECT TO THE CONDITIONS OF OUR CREDIT APPLICATION, AND IS VALID FOR 30 DAYS. THEREAFTER IT IS SUBJECT TO CHANGE WITHOUT NOTICE. FAX OR EMAIL COPY DEEMED TO BE LEGAL EQUIVALENT OF ORIGINAL. ALL PAST DUE ACCOUNTS SUBJECT TO 1 1/2% MONTHLY FINANCE CHARGE. IN THE EVENT LEGAL ACTION IS REQUIRED TO EFFECT COLLECTION VENUE SHALL BE ORANGE, CA.</small>	Subtotal
	Tax (9.25%)
	TOTAL

By: Cathy Cook Accepted _____ Date _____

PLEASE SIGN AND RETURN ONE COPY WHEN ORDERING.

Thank You!

P.O. Box 1088, Tustin, CA 92781
 P: (800) 669-2585
 F: (800) 729-2483
 www.davebang.com LIC # 795052



Quotation
 CA 132736

To **City of Agoura Hills**
Attn: Nick Newkirk
29900 Ladyface Court
Agoura Hills, Ca 91301

Quotation Date 8/17/2017	Salesperson Cathy Cook
------------------------------------	----------------------------------

Terms Net 30

*Chumash Park
 Trash Receptacles Installation*

Estimated Shipping Date 4-6 Weeks	Shipped Via Truck	F.O.B. Agoura Hills
---	-----------------------------	-------------------------------

Quantity	Description	Unit Price	Total Extended
	<p>*ACCESS CLAUSE: Customer to provide 6' access for tractor. If adequate access is not provided additional charges may apply and repairs to landscape and irrigation may be required. Customer is responsible for any repairs to landscape if proper access is not provided.</p> <p>*ROCK CLAUSE: Pricing is based on normal soil conditions which would allow an auger on a tractor to dig footings. If rocks/boulders interfere with the progress of the excavation, additional fees may apply.</p> <p>*UTILITY CLAUSE: Installation to include marking of utilities by Dig Alert. Contractor will not be responsible for any damage to unmarked utilities, such as drainage, irrigation, live water lines, main low voltage lines, etc. Customers responsibility to provide locations of any utilities prior to commencement of work.</p>		

<p>THANK YOU FOR THIS CHANCE TO QUOTE</p> <p>DAVE BANG ASSOICATES, INC OF CALIFORNIA IS PLEASED TO SUBMIT THE ABOVE QUOTATION FOR YOUR CONSIDERATION. SHOULD YOU PLACE AN ORDER, BE ASSURED IT WILL RECEIVE OUR PROMPT ATTENTION. THIS QUOTATION IS SUBJECT TO THE CONDITIONS OF OUR CREDIT APPLICATION, AND IS VALID FOR 30 DAYS. THEREAFTER IT IS SUBJECT TO CHANGE WITHOUT NOTICE. FAX OR EMAIL COPY DEEMED TO BE LEGAL EQUIVALENT OF ORIGINAL. ALL PAST DUE ACCOUNTS SUBJECT TO 1 1/2% MONTHLY FINANCE CHARGE. IN THE EVENT LEGAL ACTION IS REQUIRED TO EFFECT COLLECTION VENUE SHALL BE ORANGE, CA.</p>	Subtotal	\$2,000.00
	Tax (9.25%)	\$0.00
	TOTAL	\$2,000.00

By: Cathy Cook Accepted _____ Date _____

PLEASE SIGN AND RETURN ONE COPY WHEN ORDERING.

Thank You!

P.O. Box 1088, Tustin, CA 92781
 P: (800) 669-2585
 F: (800) 729-2483
 www.davebang.com LIC # 795052



Quotation
 CA 132731

To **City of Agoura Hills**
Attn: Nick Newkirk
29900 Ladyface Court
Agoura Hills, Ca 91301

Quotation Date 8/17/2017	Salesperson Cathy Cook
------------------------------------	----------------------------------

Terms Net 30 Piggyback Bid #15-04

*Chumash Park
 Trash Receptacles*

Estimated Shipping Date 4-6 Weeks	Shipped Via Truck	F.O.B. Agoura Hills	Quantity	Description	Unit Price	Total Extended
			9	Wabash # LR300S, 32-Gallon Trash Receptacle, Slat Pattern, portable/surface mount Color: BROWN	447.00	4,023.00
			9	Wabash # FT100N, Flat Top Lid, 8" diameter opening with inward slope Color: BLACK	84.00	756.00
			9	Wabash # LR310N, 32-Gallon Rigid Plastic Liner	29.00	261.00
			9	Wabash # LR100N, Inground Post Package Color: BROWN	59.00	531.00
				Less Colton Joint USD Piggyback Bid Discount	-835.65	-835.65
				Subtotal		4,735.35
				Shipping	1,430.00	1,430.00
				*Assembly and Installation NOT Included *Shipped by Common Carrier - Will need 2-3 people to unload * MUST SHIP WITH CA 132097 R2 and CA 131971 R1 FOR FREIGHT COSTS TO BE VALID *		

THANK YOU FOR THIS CHANCE TO QUOTE

DAVE BANG ASSOCIATES, INC OF CALIFORNIA IS PLEASED TO SUBMIT THE ABOVE QUOTATION FOR YOUR CONSIDERATION. SHOULD YOU PLACE AN ORDER, BE ASSURED IT WILL RECEIVE OUR PROMPT ATTENTION. THIS QUOTATION IS SUBJECT TO THE CONDITIONS OF OUR CREDIT APPLICATION, AND IS VALID FOR 30 DAYS. THEREAFTER IT IS SUBJECT TO CHANGE WITHOUT NOTICE. FAX OR EMAIL COPY DEEMED TO BE LEGAL EQUIVALENT OF ORIGINAL. ALL PAST DUE ACCOUNTS SUBJECT TO 1 1/2% MONTHLY FINANCE CHARGE. IN THE EVENT LEGAL ACTION IS REQUIRED TO EFFECT COLLECTION VENUE SHALL BE ORANGE, CA.

Subtotal	\$6,165.35
Tax (9.25%)	\$438.02
TOTAL	\$6,603.37

By: Cathy Cook Accepted _____ Date _____

PLEASE SIGN AND RETURN ONE COPY WHEN ORDERING.

Thank You!

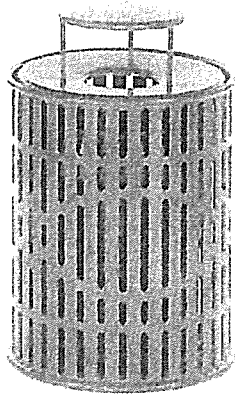

\$339

LR300(R) with SB100
(Sold separately)

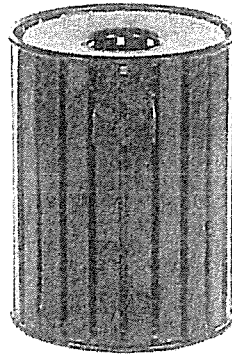

\$447

LR300(S) with FT100
(Sold separately)

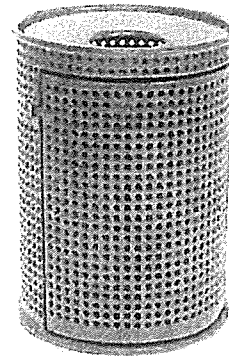

\$487

LR305(P) with FT100
(Sold separately)

STANDARD RECEPTACLES

Options: Liners, lids and mounting posts available separately for use on any size. See lids on page 77.

Perforated and rib pattern 32-Gallon receptacles available with side door option.

Patterns: Diamond, perforated, rib or slat

MODEL	DESCRIPTION	DIAMOND (D)		PERFORATED (P)	
		WEIGHT	PRICE	WEIGHT	PRICE
LR200	22-Gallon receptacle	57 lb.	\$216.00	76 lb.	\$291.00
LR300	32-Gallon receptacle	67 lb.	\$240.00	85 lb.	\$339.00
LR305	32-Gallon receptacle with side door	Not Available		111 lb.	\$487.00
		RIB (R)		SLAT (S)	
		WEIGHT	PRICE	WEIGHT	PRICE

LR200	22-Gallon receptacle	88 lb.	\$291.00	161 lb.	\$397.00
LR300	32-Gallon receptacle	106 lb.	\$339.00	175 lb.	\$447.00
LR305	32-Gallon receptacle with side door	111 lb.	\$487.00	Not Available	

MODEL	ACCESSORIES FOR ITEMS ABOVE (PATTERN OPTIONS - NOT AVAILABLE)	WEIGHT	PRICE
LR210	22-Gallon receptacle liner	4 lb.	\$26.00
LR310	32-Gallon receptacle liner	7 lb.	\$29.00
LR100	In-ground post package	12 lb.	\$59.00
LR105	Surface-mount post package	12 lb.	\$59.00

ACCESSORIES CONTINUED ▶

RECYCLE FLAT-TOP LIDS FOR RECEPTACLES

\$186
FT117

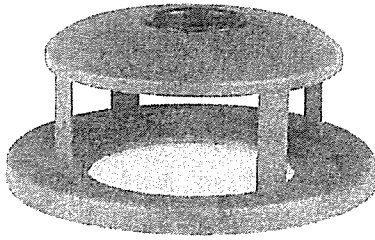

RECEPTACLE LIDS

Choose from several lid options for use on all Wabash Valley receptacles. All styles will fit any of our Standard, Flare-top or Tapered receptacles. (We offer a Flat-top lid specifically for our 55-Gallon receptacle, as other lid options won't fit.) All lids come standard with heavy-duty stainless-steel aircraft cables to secure them to the receptacles.

Choose your lid and style:
Powder-coated Flat-top lids in inward or outward slope.
Bonnet lids in solid, ashtray or serving tray options.
Cast ash/trash lid.

\$137
FT116

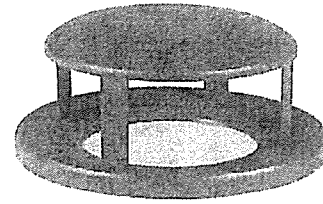







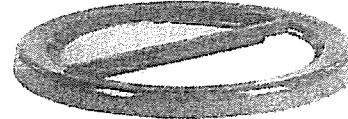



\$84
FT105



\$109
AL100



Foam-molded plastic dome-top lid.
Flat-top recycle lid labeled "Recycle Only" with 5" diameter hole opening.
Dome-top recycle lid labeled "Recycle Only" in black with 4" diameter hole opening.

 \$84 FT100	 \$103 FT106	 \$105 SB100	 \$89 DT100	 \$173 TB100
 \$88 FT115	 \$84 FT110	 \$116 AB100	 \$97 DT101	 \$77 FT107

MODEL	DESCRIPTION	WEIGHT	PRICE
FT100	Flat-top lid with 8"-diameter opening - Inward slope	9 lb.	\$84.00
FT105	Flat-top lid with 8"-diameter opening - Outward slope	7 lb.	\$84.00
FT106	Flat-top recycle lid with 5"-diameter opening - Outward slope	7 lb.	\$103.00
FT107	Recycle Flat-top lid - No label with 5"-diameter opening - Outward slope	7 lb.	\$77.00
FT110	Flat-top lid with 14"-diameter opening	8 lb.	\$84.00
FT115	Flat-top lid for 55-Gallon receptacle	12 lb.	\$88.00
FT116	Flat-top with solid bonnet for 55-Gallon receptacle	16 lb.	\$137.00
FT117	Flat-top with ash bonnet for 55-Gallon receptacle	16 lb.	\$186.00
AL100	Ash/Trash lid	13 lb.	\$109.00
DT100	Dome-top lid	12 lb.	\$89.00
DT101	Dome-top recycle lid	7 lb.	\$97.00
SB100	Flat-top with solid bonnet - Inward slope	16 lb.	\$105.00
SB105	Flat-top with solid bonnet - Outward slope	14 lb.	\$105.00
AB100	Flat-top with ashtray bonnet - Inward slope	16 lb.	\$116.00
AB105	Flat-top with ashtray bonnet - Outward slope	14 lb.	\$116.00
TB100	Flat-top with tray bonnet	21 lb.	\$173.00
DT200	Dome-top lid - (black color only)	10 lb.	\$96.00

This lid can be ordered for use on any 32-Gallon receptacle purchased prior to 2002.

P.O. Box 1088, Tustin, CA 92781
P: (800) 669-2585
F: (800) 729-2483
www.davebang.com LIC # 795052



Quotation
CA 131971 R1

To **City of Agoura Hills**
Attn: Nick Newkirk
29900 Ladyface Court
Agoura Hills, Ca 91301

Quotation Date 8/17/2017	Salesperson Cathy Cook
------------------------------------	----------------------------------

Terms Net 30
Piggyback Bid #15-04

*Chumash Park
Tables*

Estimated Shipping Date	Shipped Via	F.O.B.	Unit Price	Total Extended
4-6 Weeks	Truck	Agoura Hills		
Quantity	Description		Unit Price	Total Extended
5	Wabash # SG106P, 6' Picnic Table with 2-3/8" OD frame, Signature Series, Perforated Pattern, surface mount Color: GREEN with Black Frame		795.00	3,975.00
1	Wabash # SG115P, 8' ADA Accessible Picnic Table with 2-3/8" OD frame, Signature Series, Perforated Pattern, portable / surface mount Color: GREEN with Black Frame		843.00	843.00
	Less Colton Joint USD Piggyback Bid Discount		-722.70	-722.70
	Subtotal			4,095.30
	Shipping		1,250.00	1,250.00
<p>*Assembly and Installation NOT Included *Shipped by Common Carrier - Will need 2-3 people to unload * MUST SHIP WITH CA 132097 R2 and CA 132731 FOR FREIGHT COSTS TO BE VALID *</p>				

THANK YOU FOR THIS CHANCE TO QUOTE

DAVE BANG ASSOICATES, INC OF CALIFORNIA IS PLEASED TO SUBMIT THE ABOVE QUOTATION FOR YOUR CONSIDERATION. SHOULD YOU PLACE AN ORDER, BE ASSURED IT WILL RECEIVE OUR PROMPT ATTENTION. THIS QUOTATION IS SUBJECT TO THE CONDITIONS OF OUR CREDIT APPLICATION, AND IS VALID FOR 30 DAYS. THEREAFTER IT IS SUBJECT TO CHANGE WITHOUT NOTICE. FAX OR EMAIL COPY DEEMED TO BE LEGAL EQUIVALENT OF ORIGINAL. ALL PAST DUE ACCOUNTS SUBJECT TO 1 1/2% MONTHLY FINANCE CHARGE. IN THE EVENT LEGAL ACTION IS REQUIRED TO EFFECT COLLECTION VENUE SHALL BE ORANGE, CA.

Subtotal	\$5,345.30
Tax (9.25%)	\$378.82
TOTAL	\$5,724.12

By: Cathy Cook Accepted _____ Date _____

PLEASE SIGN AND RETURN ONE COPY WHEN ORDERING.

Thank You!

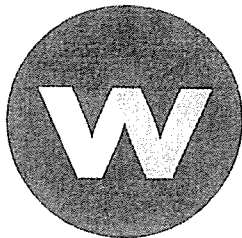

WABASH VALLEY



\$795

SG106(P)



\$19

SG135

SIGNATURE

Timeless, durable and dependable, the Signature series includes a broad spectrum of our outdoor furniture, from picnic tables to benches, in various shapes, sizes and styles—even several styles sized just for children. Built to last, they're all fabricated from steel and feature our exclusive Plastisol coating.

 For recycled version, see Green Valley page 86.

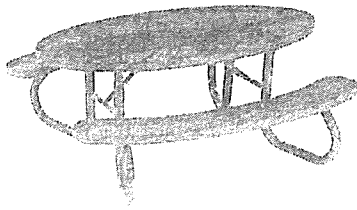

\$1,084
SG125(D)

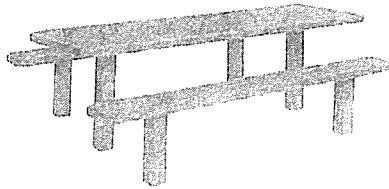

\$957
SG206(D)

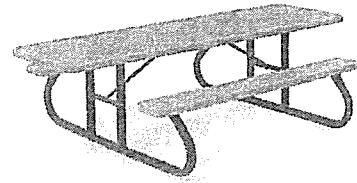

\$729
SG115(D)

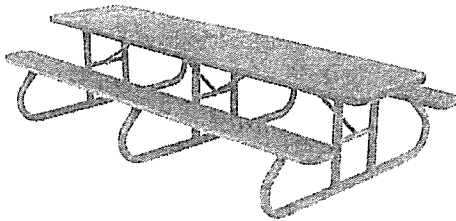

\$1,267
SG120(P)

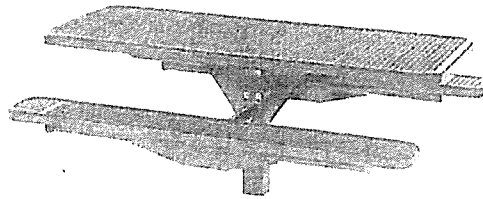

\$887
SG201(D)

DIAMOND (D)

PERFORATED (P)

MODEL DESCRIPTION

SG105	6' Picnic table - 1 5/8" O.D. frame - Portable
SG106	6' Picnic table - 2 3/8" O.D. frame - Portable
SG125	6' Oval table (table has umbrella hole) - Portable

WEIGHT PRICE WEIGHT PRICE

208 lb.	\$659.00	240 lb.	\$756.00
225 lb.	\$672.00	257 lb.	\$795.00
206 lb.	\$1,084.00	242 lb.	\$1,087.00

SG201	6' Table - Single-pedestal - In-ground	278 lb.	\$887.00	314 lb.	\$939.00
SG205	6' Table - Multi-pedestal - In-ground	302 lb.	\$866.00	334 lb.	\$912.00
SG110	8' Picnic table - 1 5/8" O.D. frame - Portable	253 lb.	\$732.00	316 lb.	\$861.00
SG111	8' Picnic table - 2 3/8" O.D. frame - Portable	270 lb.	\$747.00	333 lb.	\$898.00
SG115	8' Picnic table - 2 3/8" O.D. frame - 6' seats - Portable	254 lb.	\$729.00	308 lb.	\$843.00
SG206	8' Table - Multi-pedestal - In-ground	347 lb.	\$957.00	410 lb.	\$1,008.00
SG207	8' Table - Multi-pedestal - In-ground	328 lb.	\$931.00	382 lb.	\$993.00
SG120	10' Picnic table - 2 3/8" O.D. frame - Portable	352 lb.	\$1,113.00	412 lb.	\$1,267.00

MODEL ACCESSORIES FOR ITEMS ABOVE (PATTERN OPTIONS - NOT AVAILABLE)

QC301	Square mounting-plate covers (set of 1) (for Single-pedestal In-ground tables)	2 lb.	\$22.00
QC306	Square mounting-plate covers (set of 6) (for Multi-pedestal In-ground tables)	12 lb.	\$113.00
SG130	Surface-mount adaptor for 1 5/8" legs (set of 2) (for Portable tables)	2 lb.	\$16.00
SG135	Surface-mount adaptor for 2 3/8" legs (set of 2) (for Portable tables)	2 lb.	\$19.00

Surface and In-ground mounts must be adequately anchored.

♿ ADA-accessible

☂ Umbrella compatible

SIGNATURE CONTINUED

like this ONLY
Perforated Pattern

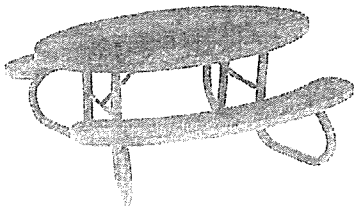

\$1,084
SG125(D)

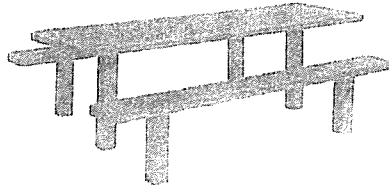

\$957
SG206(D)

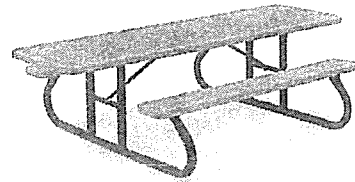

\$729
SG115(D)

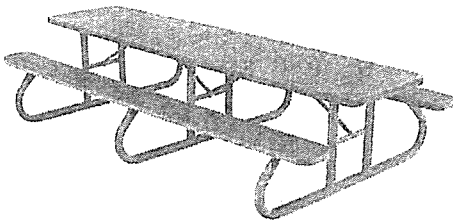

\$1,267
SG120(P)

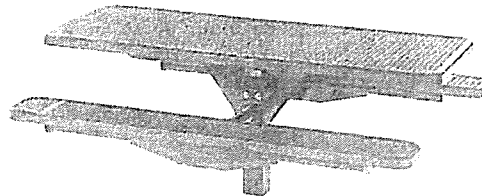

\$887
SG201(D)

MODEL	DESCRIPTION	DIAMOND (D)		PERFORATED (P)	
		WEIGHT	PRICE	WEIGHT	PRICE
SG105	6' Picnic table - 1 5/8" O.D. frame - Portable	208 lb.	\$659.00	240 lb.	\$756.00
SG106	6' Picnic table - 2 3/8" O.D. frame - Portable	225 lb.	\$672.00	257 lb.	\$795.00
SG125	6' Oval table (table has umbrella hole) - Portable	206 lb.	\$1,084.00	242 lb.	\$1,087.00
SG201	6' Table - Single-pedestal - In-ground	278 lb.	\$887.00	314 lb.	\$939.00
SG205	6' Table - Multi-pedestal - In-ground	302 lb.	\$866.00	334 lb.	\$912.00
SG110	8' Picnic table - 1 5/8" O.D. frame - Portable	253 lb.	\$732.00	316 lb.	\$861.00
SG111	8' Picnic table - 2 3/8" O.D. frame - Portable	270 lb.	\$747.00	333 lb.	\$898.00
SG115	8' Picnic table - 2 3/8" O.D. frame - 6' seats - Portable	254 lb.	\$729.00	308 lb.	\$843.00
SG206	8' Table - Multi-pedestal - In-ground	347 lb.	\$957.00	410 lb.	\$1,008.00
SG207	8' Table - Multi-pedestal - In-ground	328 lb.	\$931.00	382 lb.	\$993.00
SG120	10' Picnic table - 2 3/8" O.D. frame - Portable	352 lb.	\$1,113.00	412 lb.	\$1,267.00

MODEL	ACCESSORIES FOR ITEMS ABOVE (PATTERN OPTIONS - NOT AVAILABLE)	WEIGHT	PRICE
QC301	Square mounting-plate covers (set of 1) (for Single-pedestal In-ground tables)	2 lb.	\$22.00
QC306	Square mounting-plate covers (set of 6) (for Multi-pedestal In-ground tables)	12 lb.	\$113.00
SG130	Surface-mount adaptor for 1 5/8" legs (set of 2) (for Portable tables)	2 lb.	\$16.00
SG135	Surface-mount adaptor for 2 3/8" legs (set of 2) (for Portable tables)	2 lb.	\$19.00

Surface and In-ground mounts must be adequately anchored.

♿ ADA-accessible

☂ Umbrella compatible

SIGNATURE CONTINUED

P.O. Box 1088, Tustin, CA 92781
P: (800) 669-2585
F: (800) 729-2483
www.davebang.com LIC # 795052



Quotation
CA 132003 R1

To **City of Agoura Hills**
Attn: Nick Newkirk
29900 Ladyface Court
Agoura Hills, Ca 91301

Quotation Date 8/17/2017	Salesperson Cathy Cook
------------------------------------	----------------------------------

Terms Net 30

*Chumash Park
Tables Installation*

Estimated Shipping Date 4-6 Weeks	Shipped Via Truck	F.O.B. Agoura Hills
---	-----------------------------	-------------------------------

Quantity	Description	Unit Price	Total Extended
1	Assembly & Installation of: -(5) Wabash # SG106P, 6' Picnic Table with 2-3/8" OD frame, Signature Series, Perforated Pattern, surface mount -(1) Wabash # SG115P, 8' ADA Accessible Picnic Table with 2-3/8" OD frame, Signature Series, Perforated Pattern, portable / surface mount * MUST BE INSTALLED WITH CA 132098 R2 and CA 132736 COSTS TO BE VALID * *Prevailing Wages INCLUDED *Site Prep / Excavation NOT included *ACCESS CLAUSE: Customer to provide 6' access for tractor. If adequate access is not provided additional charges may apply and repairs to landscape and irrigation may be required. Customer is responsible for any repairs to landscape if proper access is not provided. *ROCK CLAUSE: Pricing is based on normal soil conditions which would allow an auger on a tractor to dig footings. If rocks/boulders interfere with the progress of the excavation, additional fees may apply.	3,200.00	3,200.00

THANK YOU FOR THIS CHANCE TO QUOTE

DAVE BANG ASSOCIATES, INC OF CALIFORNIA IS PLEASED TO SUBMIT THE ABOVE QUOTATION FOR YOUR CONSIDERATION. SHOULD YOU PLACE AN ORDER, BE ASSURED IT WILL RECEIVE OUR PROMPT ATTENTION. THIS QUOTATION IS SUBJECT TO THE CONDITIONS OF OUR CREDIT APPLICATION, AND IS VALID FOR 30 DAYS. THEREAFTER IT IS SUBJECT TO CHANGE WITHOUT NOTICE. FAX OR EMAIL COPY DEEMED TO BE LEGAL EQUIVALENT OF ORIGINAL. ALL PAST DUE ACCOUNTS SUBJECT TO 1 1/2% MONTHLY FINANCE CHARGE. IN THE EVENT LEGAL ACTION IS REQUIRED TO EFFECT COLLECTION VENUE SHALL BE ORANGE, CA.

Subtotal
Tax (9.25%)
TOTAL

By: Cathy Cook Accepted _____ Date _____

PLEASE SIGN AND RETURN ONE COPY WHEN ORDERING.

Thank You!

P.O. Box 1088, Tustin, CA 92781
 P: (800) 669-2585
 F: (800) 729-2483
 www.davebang.com LIC # 795052



Quotation
 CA 132003 R1

To **City of Agoura Hills**
Attn: Nick Newkirk
29900 Ladyface Court
Agoura Hills, Ca 91301

Quotation Date 8/17/2017	Salesperson Cathy Cook
------------------------------------	----------------------------------

Terms Net 30

*Chumash Park
 Tables Installation*

Estimated Shipping Date 4-6 Weeks	Shipped Via Truck	F.O.B. Agoura Hills
---	-----------------------------	-------------------------------

Quantity	Description	Unit Price	Total Extended
	*UTILITY CLAUSE: Installation to include marking of utilities by Dig Alert. Contractor will not be responsible for any damage to unmarked utilities, such as drainage, irrigation, live water lines, main low voltage lines, etc. Customers responsibility to provide locations of any utilities prior to commencement of work.		

THANK YOU FOR THIS CHANCE TO QUOTE

DAVE BANG ASSOICATES, INC OF CALIFORNIA IS PLEASED TO SUBMIT THE ABOVE QUOTATION FOR YOUR CONSIDERATION. SHOULD YOU PLACE AN ORDER, BE ASSURED IT WILL RECEIVE OUR PROMPT ATTENTION. THIS QUOTATION IS SUBJECT TO THE CONDITIONS OF OUR CREDIT APPLICATION, AND IS VALID FOR 30 DAYS. THEREAFTER IT IS SUBJECT TO CHANGE WITHOUT NOTICE. FAX OR EMAIL COPY DEEMED TO BE LEGAL EQUIVALENT OF ORIGINAL. ALL PAST DUE ACCOUNTS SUBJECT TO 1 1/2% MONTHLY FINANCE CHARGE. IN THE EVENT LEGAL ACTION IS REQUIRED TO EFFECT COLLECTION VENUE SHALL BE ORANGE, CA.

Subtotal	\$3,200.00
Tax (9.25%)	\$0.00
TOTAL	\$3,200.00

By: Cathy Cook Accepted _____ Date _____

PLEASE SIGN AND RETURN ONE COPY WHEN ORDERING.

Thank You!