

CITY OF AGOURA HILLS

CONTRACTOR PRE-QUALIFICATION

AND CONTRACT DOCUMENTS

SPECIFICATIONS AND STANDARD DRAWINGS

FOR

**COMMUNITY DEVELOPMENT BLOCK GRANT (CDBG) OLD AGOURA PARK
ACCESSIBILITY IMPROVEMENT PROJECT # 601922-17**

NIB # 18-01



Prepared By:

Robert Cortes

Reviewed By:

Charmaine Yambao

Approved By:

Ramiro S. Adeva III

RCE No. 66865

Date

Director of Public Works/City Engineer

TABLE OF CONTENTS
FOR

COMMUNITY DEVELOPMENT BLOCK GRANT (CDBG) OLD AGOURA PARK
ACCESSIBILITY IMPROVEMENT PROJECT # 601922-17
[the "Project"]

NIB # 18-01

	Page No.
NOTICE INVITING BIDS	1
INSTRUCTIONS TO BIDDERS.....	5
PROPOSAL	10
GENERAL PROVISIONS.....	29
SPECIAL PROVISIONS.....	66
CONSTRUCTION CONTRACT.....	92

APPENDICES

- APPENDIX A CONSTRUCTION PLANS
- APPENDIX B LIST OF CITY-APPROVED HAULERS
- APPENDIX C PRE-QUALIFICATION QUESTIONS PACKAGE
- APPENDIX D ADA CURB RAMP STANDARD 111-4 CASE B TYPE 1
- APPENDIX E CDBG REQUIREMENTS AND FORMS
- APPENDIX F LOS ANGELES COUNTY FLOOD CONTROL PERMIT
- APPENDIX G LOS ANGELES COUNTY LIABILITY INSURANCE REQUIREMENTS
- APPENDIX H EXCEL BRIDGE ERECTING INSTRUCTIONS

NOTICE INVITING BIDS

FOR

**COMMUNITY DEVELOPMENT BLOCK GRANT (CDBG) OLD AGOURA PARK
ACCESSIBILITY IMPROVEMENT PROJECT # 601922-17**
[the "Project"]NIB # 18-01

NOTICE IS HEREBY GIVEN that the City of Agoura Hills, California ("City") invites sealed bids for the Project. The City will receive such bids at City Hall, 30001 Ladyface Court, Agoura Hills, California 91301 up to 10:00 a.m. on April 19, 2018 at which time they will be publicly opened and read aloud.

All bids must be made on the form furnished by the City. Each bid must be submitted in a sealed package addressed to the City Clerk with the Project name and identification number typed or clearly printed on the lower left corner of the package. Bids must remain valid and shall not be subject to withdrawal for sixty (60) Days after the bid opening date.

REQUIRED CONTRACTOR PRE-QUALIFICATION

All contractors that wish to submit a bid for this project must also complete and submit the Pre-Qualification questions package included as Appendix C at the end of this document, and can be obtained by visiting <http://projects.ci.agoura-hills.ca.us>. The Pre-Qualification package is due by 10:00 AM on April 12, 2018.

The Pre-Qualification Packet must be submitted in a sealed envelope clearly identified and marked: "Pre-Qualification for Community Development Block Grant (CDBG) Old Agoura Accessibility Improvement Project # 601922-17, NIB # 18-01"

Any contractor that submits a bid package and does not submit a Pre-Qualification package will automatically be disqualified from the bidding process.

INCORPORATION OF STANDARD SPECIFICATIONS

The latest edition of "Standard Specifications for Public Works Construction" and current Supplements (collectively "Standard Specifications") are incorporated into these Contract Documents by this reference, as amended by the provisions of these Contract Documents. The Work described herein shall be done in accordance with the provisions of the Standard Specifications insofar as the same may apply, and in accordance with these Contract Documents.

SCOPE OF WORK

The Project includes, without limitation, furnishing all necessary labor, materials, equipment and other incidental and appurtenant Work necessary for the ***removal & hauling of existing asphalt, concrete, dirt, roots, equestrian fencing and grass as necessary to construct curb access ramps, two concrete driveway approaches, 5" thick access sidewalk, 6 inch thick & 6 feet wide decomposed granite path, remove existing cross-walk striping and re-stripe cross-walk on east side of the Flood Control Channel bridge, construct pile foundation for pedestrian bridge, provide equipment to unload and install a pre-fabricated 64 feet long by 10 feet wide steel pedestrian bridge by Excel Bridge Manufacturing Company or approved equal*** as more clearly described in the Contract Documents.

This Work will be performed in strict conformance with the Contract Documents, permits from

regulatory agencies with jurisdiction, and applicable regulations. The quantity of Work to be performed and materials to be furnished are approximate only, being given as a basis for the comparison of Bids. Actual quantities of Work to be performed may vary at the discretion of the City Engineer.

MANDATORY PRE-BID MEETING

A mandatory pre-bid meeting will be held at Agoura Hills' City Hall on April 12, 2018 at 10:00 AM.

OBTAINING BID DOCUMENTS

Due to the City's continuing effort in implementing "green" policies, the City encourages potential Bidders to obtain free copies of the Plans, Specifications and other Contract Documents online by visiting <http://projects.ci.agoura-hills.ca.us>. Potential Bidders may buy the printed Plans, Specifications and other Contract Documents for the Project at Agoura Hills' City Hall, 30001 Ladyface Court, Agoura Hills, California for a non-refundable fee of \$50.00 per set. The City must receive payment before these documents will be provided. These documents will not be mailed.

EMAIL ADDRESS

Anyone obtaining Contract Documents must immediately supply the Project Manager with an email address if that person or entity wants the Addenda and other information transmitted by email. The City shall also send all such documents by U.S. Mail. The City does not guarantee that it will provide any information by email, and a Bidder shall have no recourse due to not receiving such an email.

REQUESTS FOR CLARIFICATION

If you discover any error, omission, ambiguity or conflict in the Plans or Specifications and wish to have a clarification, please send a fax (818-597-7352) or email (rcortes@ci.agoura-hills.ca.us) your request for clarification to Robert Cortes such that it is received no later than 2:00 PM on April 12, 2018. Requests for clarification received after this date will be disregarded. Please indicate the Project and identification number in your request for clarification.

REGISTRATION WITH THE DEPARTMENT OF INDUSTRIAL RELATIONS

In accordance with Labor Code Sections 1725.5 and 1771.1, no contractor or subcontractor shall be qualified to bid on, be listed in a bid proposal, subject to the requirements of Section 4104 of the Public Contract Code, or engage in the performance of any contract for public work, unless currently registered and qualified to perform public work pursuant to Section 1725.5.

PREVAILING WAGES

This project is funded in whole or in part with Community Development Block Grant (CDBG) funds provided by the U.S. Department of Housing and Urban Development (HUD). Federal Labor Standards Provisions, including prevailing wage requirements of the Davis-Bacon and Related Acts will be enforced. In the event of a conflict between Federal and State Wage rates, the higher of the two will prevail.

In accordance with Labor Code Section 1770 *et seq.*, this Project is a "public work," and thus, the Contractor and any Subcontractors must pay wages in accordance with the determination of the Director of the Department of Industrial Relations ("DIR") regarding the prevailing rate of per diem wages. Copies of those rates are on file with the City Engineer, and are available to any interested party upon request. Contractor shall post a copy of the DIR's determination of the prevailing rate of per diem wages at each job site. Contractor shall post job site notices, as prescribed by regulation. This Project is subject to compliance monitoring and enforcement by the DIR.

INSURANCE AND WARRANTY

The Contractor shall provide insurance in accordance with Section 7.3 of the Standard Specifications, Section 7-3 of the General Provisions, and Los Angeles County Department of Public Works' Liability Insurance Requirements included as Appendix G. In addition, the Contractor shall guarantee and warranty all Work against defective workmanship and materials furnished by the Contractor for a period of one (1) year from the date the Work was completed and accepted by the City.

BONDS

Each Bid must be accompanied by a cash deposit, cashier's check, certified check or Bidder's Bond issued by a Surety insurer, each of which must be made payable to the City, in an amount not less than ten percent (10%) of the total Bid submitted. Personal or company checks are not acceptable. Upon award of Contract, Contractor shall provide faithful performance and payment Bonds, each in a sum equal to the Contract Price. Before acceptance of the Project, Contractor shall submit warranty/maintenance Bonds that are valid for one (1) year from acceptance, in the amount of one hundred percent (100%) of the Contract Price; in lieu of the warranty Bond, Contractor may submit proof from the Surety that the performance Bond has been extended for the appropriate duration of time. All Bonds must be issued by a California admitted Surety insurer and submitted using the required forms, which are in the Contract Documents, or in any other form approved by the City Attorney. Failure to enter into a valid contract, including the submission of all required Bonds and insurance coverages, with the City within fifteen (15) Days after the date of the delivery of the contract forms to the Bidder, shall constitute a material breach and subject the Bid security to forfeiture to the extent provided by law.

LICENSES

The Bidder shall possess a valid Class A Contractor's license issued by California State Contractors License Board at the time of the Bid submission. The successful Contractor and all Subcontractors must also possess a current City business license.

RETENTION SUBSTITUTION

Five percent (5%) of any progress payment will be withheld as retention. In accordance with Public Contract Code Section 22300, and at the request and expense of the Contractor, securities equivalent to the amount withheld may be deposited with City or with a State or federally chartered bank as escrow agent, which shall then pay such moneys to the Contractor. Upon satisfactory completion of the Contract, the securities shall be returned to the Contractor. Alternatively, Contractor may request that the City make payments of earned retentions directly to an escrow agent at Contractor's expense. No such substitutions shall be accepted until all related documents are approved by the City Attorney.

TRADE NAMES OR EQUALS

Requests to substitute an equivalent item for a brand or trade name item must be made by written request within thirty-five (35) days of Contract award. Requests received after this time shall not be considered. Requests shall clearly describe the product for which approval is requested, including all data necessary to demonstrate acceptability. If the product is acceptable, an Addendum shall be issued so indicating.

ENGINEER'S ESTIMATE

The Engineer's Estimate for this project is \$81,100.00.

LIQUIDATED DAMAGES

All Work shall be completed within 45 Working Days following the date specified in the written Notice to Proceed from the City. There will be a \$500.00 assessment for each Day that the Work remains incomplete beyond the time specified for the completion of the Work in the Contract Documents.

BIDDING PROCESS

The City reserves the right to reject any Bid or all Bids and to waive any irregularities or informalities in any Bid or in the bidding and to make awards in all or part in the best interest of the City.

By: _____
Director of Public Works/City Engineer

Date

INSTRUCTIONS TO BIDDERS

FORM OF PROPOSAL: Proposals shall be made on the Proposal forms found herein. Bidders shall include all forms and fill in all blank spaces, including inserting "N/A" (for non applicable) where necessary. The Proposal shall be enclosed in a sealed envelope bearing the name of the Bidder and the name of the Project as described in the Notice Inviting Bids.

DELIVERY OF PROPOSALS: The Proposal shall be delivered by the time and to the place stipulated in the Notice Inviting Bids. The time of delivery shall be definitively determined by the time-stamping clock located at the City Clerk's office. It is the Bidder's sole responsibility to see that this Proposal is received in proper time, and Bidders assume all risks arising out of the means of delivery. Any Proposal received after the scheduled closing time for receipt of Proposals may be returned to the Bidder unopened. Bidders or their authorized agents are invited to be present for Bid opening.

MODIFICATIONS AND ALTERNATIVE PROPOSALS: Unauthorized conditions, limitations or provisos attached to a Proposal will render it non-responsive and may be cause for rejection. The complete Proposal form must be without interlineations, alterations or erasures. No oral, telegraphic or telephonic Proposals or modifications will be considered.

WITHDRAWAL OF PROPOSAL: The Proposal may be withdrawn upon request by the Bidder without prejudice, provided that the request is in writing, has been executed by the Bidder or his or her duly authorized representative, and is filed with the City Engineer before the date and time fixed for opening of Bids. No Proposal may be withdrawn during the period of sixty (60) Days after the opening of Proposals.

BIDDER'S SECURITY: In accordance with Public Contract Code Section 20170 *et seq.*, each Proposal shall be accompanied by cash, a certified or cashier's check payable to the City, or a satisfactory Bid Bond in favor of the City executed by the Bidder as principal and an admitted surety insurer as Surety, in an amount not less than ten percent (10%) of the amount set forth in the Bid. The cash, check or Bid Bond shall be given as a guarantee that the Bidder will execute the Contract if it is awarded to him or her in conformity with the Contract Documents and all Addenda issued before Bid opening, and shall provide the evidence of insurance and furnish the necessary Bonds as specified in the Contract Documents and all Addenda issued before Bid opening, within fifteen (15) Days after written notice of the award. In case of the Bidder's refusal or failure to do so, the cash, check, or Bond, as the case may be, shall be forfeited to the City pursuant to Public Contract Code Section 20172, except as provided in Public Contract Code Section 20174. Under Section 20174, if the lowest responsible Bidder fails or refuses to execute the Contract, the City may award the Contract to the next lowest responsible Bidder; if the City does so, the amount of the lowest Bidder's security shall be applied by the City to the difference between the lowest Bid and next lowest Bid, and the surplus, if any, shall be returned to the lowest Bidder or to his or her Surety. No Bidder's Bond will be accepted unless it conforms substantially to the form provided in these Contract Documents.

QUANTITIES APPROXIMATE: The quantities shown in the Proposal form or elsewhere herein shall be considered as approximate only, being listed for the purpose of serving as a general indication of the amount of Work or materials to be performed or furnished, and as a basis for the comparison of Bids. The City does not guarantee nor agree, either expressly or by implication, that the actual amounts required will correspond with those shown, but reserves the right to increase or decrease the amount of any item or portion of Work or material to be performed or furnished or to omit any such item or portion, in accordance with the Contract Documents or any Addenda issued before Bid opening, without any way invalidating the Contract, should such increase, decrease or omission be deemed necessary or expedient.

ENGINEER'S ESTIMATE: The Engineer's Estimate for this project is \$46,000.00.

ADDENDA: The City Engineer may, from time to time, issue Addenda to the Contract Documents. Parties that have obtained the Contract Documents shall be notified of and furnished with copies of such Addenda, either by certified mail, personal delivery, or facsimile during the period of advertising at no additional cost. The City may determine, in its sole discretion, whether an Addendum requires the postponement of the date set for opening Bids. The announcement of the new date, if any, shall be made within the Addenda. **Please Note:** Bidders are primarily and ultimately responsible for ensuring that they have received any and all Addenda. To this end, each Bidder should contact the City to verify that he or she has received all Addenda issued, if any. Bidders must acknowledge receipt of all Addenda, if any, in its Proposal. Failure to acknowledge receipt of all Addenda may cause a Proposal to be deemed incomplete and non-responsive.

DISCREPANCIES IN PROPOSALS: The Bidder shall set forth as to each item of Work, in clearly legible figures, a unit or line item Bid amount for the item in the respective spaces provided for this purpose.

In case of discrepancy between the unit price and the total set forth for the item, the unit price shall prevail. However, if the amount set forth as a unit price is ambiguous, unintelligible or uncertain for any cause, or is omitted, or if the unit price is the same amount as the entry in the "Total" column, then the amount set forth in the "Total" column for the item shall prevail in accordance with the following:

(1) As to lump sum items, the amount set forth in the "Total" column shall be the unit price.

(2) As to unit price items, the amount set forth in the "Total" column shall be divided by the estimated quantity for the item and the price thus obtained shall be the unit price.

In case of discrepancy between words and figures, the words shall prevail.

COMPETENCY OF BIDDERS: In selecting the lowest responsible Bidder, consideration will be given not only to the financial standing, but also to the general competency of the Bidder for the performance of the Work covered by the Proposal. To this end each Proposal shall be supported by a statement of the Bidder's experience on the form titled "Information Required of Bidder" found herein. No agreement for the Work will be executed with a contractor who is not licensed in accordance with the laws of the State under applicable provisions of the Business and Professions Code, and with any applicable specific licensing requirements required by this Project as specified in the Contract Documents. These licensing requirements for Contractors shall apply also to all Subcontractors.

BIDDER'S EXAMINATION OF SITE AND CONTRACT DOCUMENTS: Each Bidder must carefully examine the site of the Project, the entirety of the Contract Documents and all Addenda issued. Upon submission of a Proposal, it will be assumed that the Bidder has thoroughly investigated the Work and is satisfied as to the conditions to be encountered and the character, quality, and quantities of Work to be performed and materials to be furnished. Upon Proposal submission, it shall be further assumed that the Bidder is familiar with and agrees to the requirements of the Contract Documents and all Addenda issued. The submission of a Proposal shall be considered conclusive evidence that the Bidder has made such an examination and consents thereto. No information derived from an inspection of records or investigation will in any way relieve the Contractor from his or her obligations under the Contract Documents or any Addenda issued nor entitle the Contractor to any additional compensation. By submitting his or her Proposal, the Contractor agrees not to make any claim against the City based upon ignorance or misunderstanding of any condition of the Work site or of the requirements set forth in the Contract Documents or Addenda. No claim for additional compensation will be allowed which is based on a lack of knowledge of the above items.

DISQUALIFICATION OF BIDDERS: No Person shall be allowed to make, file or be interested in more than one Bid for the same project, unless alternate Bids are specifically called for. A Person that has submitted a sub-proposal to a Bidder, or that has quoted prices of materials to a Bidder, is not hereby disqualified from submitting a sub-proposal or quoting prices to other Bidders or making a prime Proposal. If there is a reason to believe that collusion exists among the Bidders, all affected Bids will be rejected.

RETURN OF BID SECURITY: The successful Bidder's Proposal security shall be held until the Contract is executed. Bid security shall be returned to the unsuccessful Bidders within a reasonable time, which in any case shall not exceed sixty (60) Days after the successful Bidder has signed the Contract.

AWARD OF CONTRACT: The City reserves the right to reject any or all Proposals or any parts thereof or to waive any irregularities or informalities in any Proposal or in the bidding. The award of the Contract, if made, will be to the lowest responsible Bidder within sixty (60) Days after the opening of the Proposals, except that the award may be made after that period if the successful Bidder has not given the City written notice of the withdrawal of his or her Bid.

ADDITIVE OR DEDUCTIVE ITEMS: If additive or deductive items are included in a Bid, the lowest Bid shall be the Proposal with the lowest Bid price on the base amount without consideration of the prices on the additive or deductive items. These determination methods shall be used regardless of whether additive or deductive items are required, which in any case shall be at the City's discretion.

LISTING SUBCONTRACTORS: Each Bidder shall submit a list of the proposed Subcontractors on this Project, as required by the Subletting and Subcontracting Fair Practices Act (Public Contract Code Section 4100, *et seq.*). A form for this purpose is furnished with the Proposal. The Contractor shall perform, with its own organization (rather than with Subcontractors), Work amounting to at least fifty percent (50%) of the Contract Price.

EXECUTION OF CONTRACT: The Bidder to whom award of the Project is made shall execute a written contract with the City in the form included in these Contract Documents within fifteen (15) Days from the date of mailing of written notice of the award. This Bidder shall also secure all insurance and Bonds as herein specified, and provide copies therefor to the City, within fifteen (15) Days from the date of mailing of written notice of the award. Failure or refusal to enter into the Contract or to conform to any of the stipulated requirements shall be just cause for the annulment of the award and forfeiture of the Bidder's security. In the event the Bidder to whom an award is made fails or refuses to execute the Contract within that time, the City may declare the Bidder's security forfeited, and the City Council may award the Work to the next lowest responsible Bidder, or may call for new Bids. Where the City Council awards the Work to the next lowest responsible Bidder, pursuant to Public Contract Code Section 20174, the amount of the lowest Bidder's security shall be applied to the difference between the lowest and next lowest Bid and the surplus, if any, shall be returned to the lowest Bidder or to his or her Surety. If the second lowest responsible Bidder fails or refuses to execute the Contract, the City Council may award the Contract to the third lowest responsible Bidder pursuant to Public Contract Code Section 20174.

SIGNATURES: The Bidder or his, her or its authorized representative shall execute all documents requiring signatures, including but not limited to various forms in the Proposal, various forms in the Contract, and Bonds. Bidders shall provide evidence satisfactory to the City, such as an authenticated resolution of its Board of Directors or a Power of Attorney, indicating the capacity of the person signing the Proposal to bind the Bidder to each Proposal and to any Contract arising therefrom.

INSURANCE AND BONDS: The Contractor shall not begin Work under the Contract until it has given the City evidence of all required insurance coverage, including all additional insured endorsements. The Contractor also shall not begin Work under the Contract until it has furnished to the City two Bonds: one guaranteeing the Contractor's faithful performance of the Contract, and other securing the

payment of claims for labor and material. Each of these Bonds shall be executed in a sum equal to the Contract amount. Before acceptance of the Project, the Contractor shall submit warranty/ maintenance Bond(s) that are valid for 1 year from acceptance, as further described in the General Provisions.

INDEMNITY: The indemnity shall be as written in Section 7.3 of the General Provisions.

TELEPHONES: Bidders are hereby notified that the City will not provide telephones for their use at the time of receipt of Bids.

INTERPRETATION OF CONTRACT DOCUMENTS: If any Bidder is in doubt as to the intended meaning of any part of the Contract Documents, or finds discrepancies in or omissions from the Contract Documents, he or she may submit to the City Engineer a written request for an interpretation or correction not later than ten (10) Days before Bid opening. The Person submitting the request will be responsible for its prompt delivery, and no requests will be accepted or considered after that time. Any interpretation or correction of the Contract Documents will be made only by an Addendum duly issued and mailed, with a copy of such Addendum faxed or emailed, to each Person receiving a set of the Contract Documents. No oral interpretation of any provision in the Contract Documents shall be binding.

TAXES: Except as may be otherwise specifically provided herein, all sales and/or use taxes assessed by federal, State or local authorities on materials used or furnished by the Contractor in performing the Work hereunder shall be paid by the Contractor. Contractor shall calculate payment for all sales, unemployment, pension and other taxes imposed by federal, State, and local law and shall include these payments in the total Proposal.

CHECKLIST FOR BIDDERS

The following information is required of all Bidders prior to the time of the Bid:

_____ Completed Pre-Qualification Package

The following information is required of all Bidders at the time of the Bid:

_____ Completed and Signed Proposal

_____ Completed and Signed Bid Schedule

_____ Completed, Signed and Notarized Information Required of Bidders Form

_____ Completed References Sheet

_____ Attached Resume of General Construction Superintendent or on-site Construction Manager for the Contractor

_____ Completed Designation of Subcontractors Form

_____ Completed and Signed Contractor's Industrial Safety Record

_____ Completed, Signed and Notarized Bid Bond or Other Security

_____ Signed and Notarized Non-Collusion Declaration

_____ Completed and Signed Acknowledgement of Addenda

_____ All Addenda (if applicable)

Failure of the Bidder to provide all required information in a complete and accurate manner may be considered non-responsive.

PROPOSAL

CITY OF AGOURA HILLS

**COMMUNITY DEVELOPMENT BLOCK GRANT (CDBG) OLD AGOURA PARK ACCESSIBILITY
IMPROVEMENT PROJECT # 601922-17**

[NIB # 18-01]

TO THE HONORABLE MAYOR AND CITY COUNCIL OF THE CITY OF AGOURA HILLS:

The undersigned, as Bidder, declares that: (1) this Proposal is made without collusion with any other Person and that the only Persons or parties interested as principals are those named herein; (2) Bidder has carefully examined the Contract Documents and all Addenda as well as the site of the proposed Work; and (3) Bidder has investigated and is satisfied as to the conditions to be encountered, the character, quality and quantities of Work to be performed and materials to be furnished. Furthermore, the undersigned agrees that submission of this Proposal shall be conclusive evidence that such examination and investigation have been made and agrees, in the event this Contract be awarded to Bidder, to enter into the Contract with the City of Agoura Hills to perform the proposed Project in accordance with the Contract Documents and all Addenda in the time and manner therein prescribed, and to furnish or provide all materials, labor, tools, equipment, apparatus and other means necessary so to do, except as may otherwise be furnished or provided under the terms of the Contract Documents and Addenda, for the following stated unit prices or lump-sum price as submitted on the Bid herein.

The undersigned submits as part of this Proposal a completed copy of the Contractor's Industrial Safety Record. This Safety Record includes all construction Work undertaken in the State by the Bidder and any partnership, joint venture or corporation that any principal of the Bidder participated in as a principal or owner for the last five (5) calendar years and the current calendar year before the date of Bid submittal. Separate information is being submitted for each such partnership, joint venture, or corporate or individual Bidder. The Bidder may attach any additional information or explanation of data which he or she would like to be taken into consideration in evaluating the Safety Record. An explanation of the circumstances surrounding any and all fatalities must be attached.

Accompanying this Proposal is cash, a cashier's check, a certified check or a Bidder's Bond in an amount equal to at least ten percent (10%) of the total aggregate Bid price hereof based on the quantities shown and the unit prices quoted. The undersigned Bidder further agrees that should he or she be awarded the Contract on the basis hereof and thereafter fails or refuses to enter into the Contract and provide the required evidence of insurance and Bonds within fifteen (15) Days after written notice of the award, the cash, check or Bid Bond shall be forfeited to the City in accordance with Public Contract Code Section 20172, except as otherwise provided in Public Contract Code Section 20174.

The undersigned certifies to have a minimum of three (3) consecutive years of current experience in the type of Work related to this Project and that this experience is in actual operation of the firm with permanent employees performing a part of the Work as distinct from a firm operating entirely by subcontracting all phases of the Work. The undersigned also certifies to be properly licensed by the State as a contractor to perform this type of Work and further certifies to have been so licensed for the three (3) years immediately preceding the date of receipt of Bids. The undersigned possesses California Contractor's License Number _____, Class _____, which expires on _____.

Bidder's name: _____

Signature: _____

Date: _____

Signature: _____

Date: _____

CITY OF AGOURA HILLS

BID SCHEDULE

**COMMUNITY DEVELOPMENT BLOCK GRANT (CDBG) OLD AGOURA PARK ACCESSIBILITY
IMPROVEMENT PROJECT # 601922-17
[NIB # 18-01]**

Bidder's Name: _____

To the Honorable Mayor and Members of the City Council:

In compliance with the Notice Inviting Bids, the undersigned hereby agrees to enter into the Contract to furnish all labor, materials, equipment and supplies for the Project in accordance with the Contract Documents, as that term is defined in the Standard Specifications, to the satisfaction and under the direction of the City Engineer, at the following prices:

BASE AMOUNT:

BID ITEM NO.	DESCRIPTION	UNIT	ESTIMATED QUANTITY	UNIT PRICE	ESTIMATE COST
1.	Mobilization	LS	1	\$	\$
2.	Construction Surveying & Stakeout	LS	1	\$	\$
3.	ADA Curb Ramps Standard 111-4, Case B, Type 1	EA	4	\$	\$
4.	Build Up Decomposed Granite (Stabilized) Surface on Both Sides of Bridge Abutments	SF	1,300	\$	\$
5.	6 Inches Thick & 6 Feet Wide Decomposed Granite (Stabilized) Path	SF	1,410	\$	\$
6.	Concrete Driveway Approaches	EA	2	\$	\$

7.	Concrete Bridge Piles with Steel Sleeve, steel reinforcement & Abutments	LS	1	\$	\$
8.	Unload & Install Bridge & Deck	LS	1	\$	\$
9.	Remove Existing Street Cross Walk Striping & Re-Stripe New Cross Walk E/O Bridge	LS	1	\$	\$

TOTAL BASE ITEM AMOUNT: \$ _____

Note: Several items may be adjusted or deleted. Any changes to the quantities for these items shall not classify as a substantial change as stipulated in Section 3-2.2.1 of the Standard Specifications. Therefore, regardless of total actual volume (percentage) compared to estimated quantities, the unit prices provided above by the Bidder shall be applied to the final quantity when payment is calculated for these items. No adjustment in the unit prices will be allowed. The City reserves the right to not use any of the estimated quantities, and if this right is exercised, the Contractor will not be entitled to any additional compensation.

TOTAL BID PRICE IN DIGITS: \$ _____

TOTAL BID PRICE IN WORDS: _____

Signature: _____ Title: _____ Date: _____

Signature: _____ Title: _____ Date: _____

If additive or deductive items are included in a Bid, the lowest Bid shall be the Proposal with the lowest Bid price on the base amount without consideration of the prices on the additive or deductive items. These determination methods shall be used regardless of whether additive or deductive items are required, which in any case shall be at the City's discretion.

INFORMATION REQUIRED OF BIDDER

Fill out all of the following information. Attach additional sheets if necessary.

(1) Bidder's name: _____

(2) If the Bidder's name is a fictitious name, who or what is the full name of the registered owner? If the Bidder's name is not a fictitious name, write "N/A" in the response to this question. If you are doing business under a fictitious name, provide a copy of the filed valid Fictitious Business Name Statement.

(3) Business address: _____

(4) Telephone: _____ Facsimile: _____

(5) Type of firm – Individual, Partnership, LLC or Corporation: _____

(6) Corporation organized under the laws of the state of: _____

(7) California State Contractor's License Number and Class: _____

(8) Original Date Issued: _____ Expiration Date: _____

(9) DIR Contractor Registration Number: _____

(10) List the name and title of the person(s) who inspected the site of the proposed Work for your firm:

(11) List the name and title of the person(s) who attended the mandatory pre-bid meeting for this Project, including the mandatory site visit, for your firm, if any:

(12) Number of years of experience the company has as a contractor in construction work: _____

(13) List the names, titles, addresses and telephone numbers of all individuals, firm members, partners, joint venturers, and company or corporate officers having a principal interest in this Proposal:

(14) List all current and prior D.B.A.'s, aliases, and fictitious business names for any principal having interest in this Proposal:

(15) List the dates of any voluntary or involuntary bankruptcy judgments against any principal having an interest in this Proposal:

(16) For all arbitrations, lawsuits, settlements and the like (in or out of court) the company or any principal having an interest in this Proposal has been involved with in the past five (5) years:

a. List the names, addresses and telephone numbers of contact persons for the parties:

b. Briefly summarize the parties' claims and defenses:

c. State the tribunal (e.g., Superior Court, American Arbitration Association, etc.), the matter number, and the outcome:

(17) Has the company or any principal having an interest in this Proposal ever had a contract terminated by the owner or agency? If so, explain.

(18) Has the company or any principal having an interest in this Proposal ever failed to complete a project? If so, explain.

(19) Has the company or any principal having an interest in this Proposal ever been terminated for

cause, even if it was converted to a "termination of convenience"? If so, explain.

(20) List the dates of any voluntary or involuntary bankruptcy judgments against any principal having an interest in this Proposal:

(21) For projects that the company or any principal having an interest in this Proposal has been involved with in the last five (5) years, did you have any claims or actions:

- a. By you against the owner? Circle one: Yes No
- b. By the owner against you? Circle one: Yes No
- c. By any outside agency or individual for labor compliance? Circle one: Yes No
- d. By Subcontractors? Circle one: Yes No
- e. Are any of these claims or actions unresolved or outstanding? Circle one: Yes No

If your answer is "yes" to any part or parts of question (20), explain.

(22) List the last three (3) projects you have worked on or are currently working on for the City of Agoura Hills:

Upon request of the City, the Bidder shall furnish evidence showing a notarized financial statement, financial data, construction experience, or other additional information.

The Bidder certifies under penalty of perjury under the laws of the State that the information provided above is true and correct.

Notary Public

Company

Subscribed and sworn to me _____

Signature: _____

Signature: _____

Title: _____

This _____ day of _____, 20_____

Date: _____

Title: _____ Signature: _____
Signature: _____ Title: _____
(SEAL) Date: _____

REFERENCES

For all public agency projects in excess of \$15,000 you are currently working on or have worked on in the past two (2) years, provide the following information:

Project 1 Name/ Number _____

Project Description _____

Approximate Construction Dates From: _____ To: _____

Agency Name: _____

Contact Person: _____ Telephone: _____

Address: _____

Original Contract Amount: \$ _____ Final Contract Amount: \$ _____

If final amount is different from original amount, please explain (change orders, extra work, etc.)

Did you file any claims against the Agency? Circle one: Yes No

Did the Agency file any claims against you? Circle one: Yes No

If you answered yes to either of the above two questions, please explain and indicate outcome of claims.

Project 2 Name/ Number _____

Project Description _____

Approximate Construction Dates From: _____ To: _____

Agency Name: _____

Contact Person: _____ Telephone: _____

Address: _____

Original Contract Amount: \$ _____ Final Contract Amount: \$ _____

If final amount is different from original amount, please explain (change orders, extra work, etc.)

Did you file any claims against the Agency? Circle one: Yes No

Did the Agency file any claims against you? Circle one: Yes No

If you answered yes to either of the above two questions, please explain and indicate outcome of claims.

Project 3 Name/ Number _____

Project Description _____

Approximate Construction Dates From: _____ To: _____

Agency Name: _____

Contact Person: _____ **Telephone:** _____

Address: _____

Original Contract Amount: \$ _____ Final Contract Amount: \$ _____

If final amount is different from original amount, please explain (change orders, extra work, etc.)

Did you file any claims against the Agency? Circle one: Yes No

Did the Agency file any claims against you? Circle one: Yes No

If you answered yes to either of the above two questions, please explain and indicate outcome of claims.

Project 4 Name/ Number _____

Project Description _____

Approximate Construction Dates From: _____ To: _____

Agency Name: _____

Contact Person: _____ Telephone: _____

Address: _____

Original Contract Amount: \$ _____ Final Contract Amount: \$ _____

If final amount is different from original amount, please explain (change orders, extra work, etc.)

Did you file any claims against the Agency? Circle one: Yes No

Did the Agency file any claims against you? Circle one: Yes No

If you answered yes to either of the above two questions, please explain and indicate outcome of claims.

Project 5 Name/ Number _____

Project Description _____

Approximate Construction Dates From: _____ To: _____

Agency Name: _____

Contact Person: _____ Telephone: _____

Address: _____

Original Contract Amount: \$ _____ Final Contract Amount: \$ _____

If final amount is different from original amount, please explain (change orders, extra work, etc.)

Did you file any claims against the Agency? Circle one: Yes No

Did the Agency file any claims against you? Circle one: Yes No

If you answered yes to either of the above two questions, please explain and indicate outcome of claims.

Project 6 Name/ Number _____

Project Description _____

Approximate Construction Dates From: _____ To: _____

Agency Name: _____

Contact Person: _____ Telephone: _____

Address: _____

Original Contract Amount: \$ _____ Final Contract Amount: \$ _____

If final amount is different from original amount, please explain (change orders, extra work, etc.)

Did you file any claims against the Agency? Circle one: Yes No

Did the Agency file any claims against you? Circle one: Yes No

If you answered yes to either of the above two questions, please explain and indicate outcome of claims.

RESUME

Attach to this Bid the experience resume of the person who will be designated as General Construction Superintendent or on-site Construction Manager for the Contractor.

DESIGNATION OF SUB-CONTRACTORS
[Public Contract Code Section 4104]

List all Subcontractors doing Work in an amount in excess of 0.5% of the Contractor's total Bid or, in the case of Bids or hours offers for the construction of Streets or highways (including bridges), in excess of 0.5% of the Contractor's total Bid or \$10,000, whichever is greater. If all Subcontractors do not fit on this page, attach another page listing all information for all other Subcontractors.

Name under which Subcontractor is Licensed and Registered	CSLB License Number(s) and Class(es)	DIR Contractor Registration Number	Address and Phone Number	Type of Work (e.g., Electrical)	Percentage of Total Bid (e.g., 10%) ¹

* The percentage of the total bid shall represent the "portion of the work" for the purposes of Public Contract Code Section 4104(b).

¹ The percentage of the total Bid shall represent the "portion of the work" for the purposes of Public Contract Code Section 4104(b).

CONTRACTOR'S INDUSTRIAL SAFETY RECORD

Bidder's Name _____

	Current Year of Record	2017	2016	2015	2014	2013	Total	Year
Number of contracts								
Total dollar amount of contracts (in thousands of dollars)								
Number of fatalities								
Number of lost workday cases								
Number of lost workday cases involving permanent transfer to another job or termination of employment								

The above information was compiled from the records that are available to me at this time and I declare under penalty of perjury that the information is true and accurate within the limitations of those records.

Signature: _____

Signature: _____

Title: _____

Title: _____

Date: _____

Date: _____

Bond No.

BID BOND

KNOW ALL PERSONS BY THESE PRESENTS that:

WHEREAS the City of Agoura Hills ("Public Agency"), has issued an invitation for Bids for the Work described as follows:

WHEREAS _____
(Name and address of Bidder)

("Principal"), desires to submit a Bid to Public Agency for the Work.

WHEREAS, Bidders are required under the provisions of the California Public Contract Code to furnish a form of Bidder's security with their Bid.

NOW, THEREFORE, we, the undersigned Principal, and _____

(Name and address of Surety)

("Surety") a duly admitted surety insurer under the laws of the State of California, as Surety, are held and firmly bound unto the Public Agency in the penal sum of _____

Dollars (\$ _____), being not less than ten percent (10%) of the total Bid price, in lawful money of the United States of America, for the payment of which sum well and truly to be made, we bind ourselves, our heirs, executors, administrators, successors, and assigns, jointly and severally, firmly by these presents.

THE CONDITION OF THIS OBLIGATION IS SUCH THAT, if the hereby bounded Principal is awarded a contract for the Work by the Public Agency and, within the time and in the manner required by the bidding specifications, enters into the written form of contract included with bidding specifications, furnishes the required Bonds, one to guarantee faithful performance and the other to guarantee payment for labor and materials, and furnishes the required insurance coverage, then this obligation shall become null and void; otherwise, it shall be and remain in full force and effect.

In case suit is brought upon this Bond, Surety further agrees to pay all court costs incurred by the Public Agency in the suit and reasonable attorneys' fees in an amount fixed by the court. Surety hereby waives the provisions of California Civil Code Section 2845.

IN WITNESS WHEREOF, this instrument has been duly executed by Principal and Surety, on the date set forth below, the name of each corporate party being hereto affixed and these presents duly signed by its undersigned representative(s) pursuant to authority of its governing body.

Dated: _____

“Principal”

“Surety”

By: _____
Its

By: _____
Its

By: _____
Its

By: _____
Its

(Seal)

(Seal)

Note: This Bond must be dated, all signatures must be notarized, and evidence of the authority of any person signing as attorney-in-fact must be attached.

**NONCOLLUSION DECLARATION
TO BE EXECUTED BY BIDDER AND SUBMITTED WITH BID
[Public Contract Code 7106]**

The undersigned declares:

I am the _____ of _____, the party making the foregoing Bid.

The Bid is not made in the interest of, or on behalf of, any undisclosed Person, partnership, company, association, organization, or corporation. The Bid is genuine and not collusive or sham. The Bidder has not directly or indirectly induced or solicited any other Bidder to put in a false or sham Bid. The Bidder has not directly or indirectly colluded, conspired, connived, or agreed with any Bidder or anyone else to put in a sham Bid, or to refrain from bidding. The Bidder has not in any manner, directly or indirectly, sought by agreement, communication, or conference with anyone to fix the Bid price of the Bidder or any other Bidder, or to fix any overhead, profit, or cost element of the Bid price, or of that of any other Bidder. All statements contained in the Bid are true. The Bidder has not, directly or indirectly, submitted his or her Bid price or any breakdown thereof, or the contents thereof, or divulged information or data relative thereto, to any corporation, partnership, company, association, organization, Bid depository, or to any member or agent thereof, to effectuate a collusive or sham Bid, and has not paid, and will not pay, any Person or entity for such purpose.

Any person executing this declaration on behalf of a Bidder that is a corporation, partnership, joint venture, limited liability company, limited liability partnership, or any other entity, hereby represents that he or she has full power to execute, and does execute, this declaration on behalf of the Bidder.

I declare under penalty of perjury under the laws of the State of California that the foregoing is true and correct and that this declaration is executed on _____ [date], at _____ [city], _____ [state]."

Signature _____

Signature _____

Printed Name: _____

Printed Name: _____

Date: _____

Date: _____

This form must be notarized.

ACKNOWLEDGMENT OF ADDENDA

Bidder's Name: _____

The Bidder shall signify receipt of all Addenda here, if any:

Addendum Number	Date Received	Signature

If there are more Addenda than there is room in the chart above, attach another page acknowledging receipt of the Addenda.

GENERAL PROVISIONS

SECTION 0. GENERAL PROVISIONS DEFINED

0-1 STANDARD SPECIFICATIONS

The Work described herein shall be done in accordance with the provisions of the latest edition of the Standard Specifications (defined in the Notice Inviting Bids), and all supplemental modifications of the Standard Specifications, as hereinafter delineated, except for those provisions that are expressly not incorporated by a provision in these Contract Documents.

0-2 NUMBERING OF SECTIONS

The number of sections and subsections in these modifications are compatible with the numbering in the Standard Specifications. The Special Provisions will be numbered as Sections 700 through 799. Subsections of architectural and/or other work may be numbered according to the Construction Specifications Institute (CSI) format.

0-3 SUPPLEMENTATION OF STANDARD SPECIFICATIONS

The Sections that follow supplement but do not replace the Standard Specifications, except as otherwise indicated herein.

SECTION 1. TERMS, DEFINITIONS, ABBREVIATIONS, UNITS OF MEASURE, AND SYMBOLS

1-2 TERMS AND DEFINITIONS

Whenever in the Standard Specifications or in the Contract Documents the following terms are used, they shall be understood to mean the following:

Agency – The City of Agoura Hills.

Board – The City Council of the City of Agoura Hills.

Contract Documents – As defined in Standard Specifications section 1-2, but also including the General Provisions.

County – County of Los Angeles, California

Due Notice – A written notification, given in due time, of a proposed action where such notification is required by the Contract to be given a specified interval of time (usually 48 hours or two working days) prior to the commencement of the contemplated action.

Engineer – The City Engineer, acting either directly or through properly authorized agents. Such agents shall act within the scope of the particular duties entrusted to them.

Inspector – An authorized representative of the City, assigned by the City to make inspections of Work performed by or material supplied by the Contractor.

Laboratory – A laboratory authorized by the City to test materials and Work involved in the Contract.

Project – See Scope of Work.

Prompt – The briefest interval of time required for a considered reply, including time required for approval by a governing body.

City-Approved Hauler – A hauler that is permitted to provide hauling/recycling services in the City of Agoura Hills (Appendix B).

Submittal – Any drawing, calculation, specification, product data, samples, manuals, requests for substitutes, spare parts, photographs, survey data, traffic control plans, record drawings, bonds or similar items required to be submitted to the City under the terms of the Contract.

1-3.3 INSTITUTIONS

The institutions listed in Section 1-3.3 of the Standard Specifications shall be supplemented by the list below:

<u>Abbreviation</u>	<u>Word or Words</u>
AAN	American Association of Nurserymen
ACI	American Concrete Institute
AGCA	Associated General Contractors of America
APWA	American Public Works Association
ASME	American Society of Mechanical Engineers
CRSI	Concrete Reinforcing Steel Institute
CSI	Construction Specifications Institute
IEEE	Institute of Electric and Electronic Engineers
NEC	National Electric Code
NEMA	National Electrical Manufacturers Association
NFPA	National Fire Protection Association
SSS	State of California Standard Specifications, latest edition, Department of Transportation
SSP	State of California Standard Plans, latest edition, Department of Transportation

SECTION 2. SCOPE AND CONTROL OF THE WORK

Section 2-3.2 (“Self Performance”) of the Standard Specifications shall not be incorporated, and shall instead be replaced with the following:

The Contractor shall perform or provide, with its own organization, Contract labor, materials and equipment amounting to at least fifty percent (50%) of the Contract Price. The Contract labor performed or provided by the Contractor shall amount to at least twenty-five percent (25%) of the total Contract labor. Contract labor shall exclude superintendence. Any “Specialty Items,” which will be identified by the City in the Bid or in the Special Provisions, may be performed by subcontract, and the amount of any such “Specialty Items” so performed may be deducted from the Contract Price before computing the amount of Contract labor, materials, and equipment required to be performed or provided by the Contractor with its own organization. Where an entire item is subcontracted, the value of Contract labor, materials, and equipment subcontracted will be based on the Contract Unit Price or lump-sum price. When a portion of an item is subcontracted, the value of Contract labor, materials, and equipment subcontracted will

be based on the estimated percentage of the Contract Unit or lump-sum price, determined from information submitted by the Contractor and subject to approval by the City Engineer.

Otherwise, the provisions below shall supplement but not replace those provisions in Section 2 of the Standard Specifications.

2-2 ASSIGNMENT

Any purported assignment without written consent of the City shall be null, void, and of no effect, and Contractor shall hold harmless, defend and indemnify the City and its officers, officials, employees, agents and representatives with respect to any claim, demand or action arising from or relating to any unauthorized assignment.

If the City opts to consent to assignment, the City's consent shall be contingent upon: 1) a letter from the Surety company agreeing to the assignment and assigning all of the Bonds to the assignee without any reduction, or the assignee supplying all new Bonds in the amounts originally required under the Contract Documents; and 2) the assignee supplying all of the required insurance in the amounts required in the Contract Documents. Until the Surety assigns all of the Bonds or the assignee supplies all of the new Bonds, and until the assignee supplies all of the required insurance, an assignment otherwise consented to in writing by the City shall not be effective. Even if the City consents to assignment, no assignment shall relieve the Contractor of liability under the Contract.

2.4 CONTRACT BONDS

Before acceptance of the Project, Contractor shall submit warranty or maintenance Bond(s) that are valid for one (1) years from date of recordation of Notice of Completion by County Recorder, in the amount of one hundred percent (100%) of the Contract amount. In lieu of the warranty or maintenance Bond(s), before acceptance of the Project, Contractor may submit written evidence from the Surety that the performance Bond has been extended for the appropriate duration of time. Other than the details listed herein, the warranty or maintenance Bond shall adhere to the requirements for Bonds in Section 2-4 of the Standard Specifications. Nothing herein shall abridge or amend Section 6-8.3 of the Standard Specifications or the related provisions in these Contract Documents.

The Faithful Performance Bond shall remain in force until the date of recordation of the Notice of Completion. The Material and Labor Bond shall remain in force until expiration of the time within which the California Labor Commissioner may serve a civil wage and penalty assessment against the principal, any of its subcontractors, or both the principal and its subcontractors pursuant to Labor Code Section 1741, and until the expiration of the time within which a joint labor management committee may commence an action against the principal, any of its subcontractors, or both the principal and its subcontractors pursuant to Labor Code Section 1771.2.

All Bonds must be submitted using the required forms, which are in the Contract Documents, or on any other form approved by the City Attorney.

2.5 PLANS AND SPECIFICATIONS

In addition to the requirements under Section 2-5.1 in the Standard Specifications, the Contractor shall maintain a control set of Plans and Specifications on the Project site at all times. All final locations determined in the field, and any deviations from the Plans and Specifications, shall be marked in red on said control set to show the as-built conditions. These control set of Plans shall also be edited for all Addenda, Requests for Information, Change Orders, field changes not involving cost, and any other

variation that occurred during construction. Upon completion of all Work, the Contractor shall return the control set to the City Engineer. Final payment will not be made until this requirement is met.

Where a work feature is shown on the drawings or identified in the specifications but is not specifically indicated as an item in the bid schedule, and there is no ambiguity regarding the requirement to construct, install, or construct and install that work feature, the Contractor is required to complete the work feature. All costs to the Contractor for constructing, installing, or both constructing and installing such a work feature shall be included in the Bid.

2-5.2 Precedence of the Contract Documents

With regard to Section 2-5.2 in the Standard Specifications, the General Provisions shall control over the Special Provisions, and the Notice Inviting Bids and Instructions to Bidders (in that order) shall control over the Bid, such that the order of precedence shall be as follows:

- (1) Permits issued by regulatory agencies with jurisdiction.
- (2) Change Orders and Supplemental Agreements; whichever occurs last.
- (3) Contract/ Agreement.
- (4) Addenda.
- (5) Notice Inviting Bids.
- (6) Instructions to Bidders.
- (7) Bid/ Proposal.
- (8) General Provisions.
- (9) Special Provisions.
- (10) Plans.
- (11) Standard Plans.
- (12) Standard Specifications.
- (13) Reference Specifications.

2-7 SUBSURFACE DATA

If the City or its consultants have made investigations of subsurface conditions in areas where the Work is to be performed, such investigations shall be deemed made only for the purpose of study and design. If a geotechnical or other report has been prepared for the Project, the Contractor may inspect the records pertaining to such investigations subject to and upon the conditions hereinafter set forth. The inspection of the records shall be made in the Office of the City Engineer. It is the Contractor's sole responsibility to determine whether such investigations exist and the City makes no affirmative or negative representation concerning the existence of such investigations.

The records of any such investigations are made available solely for the convenience of the Contractor. It is expressly understood and agreed that the City, the City Engineer, their agents, consultants or employees assume no responsibility whatsoever with respect to the sufficiency or accuracy of any investigations, the records thereof, and the interpretations set forth therein. No warranty or guarantee is expressed or implied that the conditions indicated by any such investigations or records are representative of those existing in the Project area. The Contractor agrees to make such independent investigations and examination as necessary to be satisfied of the conditions to be encountered in the performance of the Work.

The Contractor represents that he or she has studied the Plans, Specifications and other Contract

Documents, and all surveys and investigation reports of subsurface and latent physical conditions, has made such additional surveys and investigations as necessary for the performance of the Work at the Contract Price in accordance with the requirements of the Contract Documents, and that he or she has correlated the results of all such data with the requirements of the Contract Documents. No claim of any kind shall be made or allowed for any error, omission or claimed error or omission in whole or in part, of any geotechnical exploration or any other report or data furnished or not furnished by the City.

2-9 SURVEYING

Contractor shall verify all dimensions on the drawings and shall report to the City any discrepancies before proceeding with related Work. Contractor shall perform all survey and layout Work per the benchmark information on the Project Plans. All surveying Work must conform to the Professional Land Surveyors' Act, California Business and Professions Code Section 8700 *et seq.* All Project surveying notes "and cut-sheets" are to be provided to the City after the completion of each surveying activity and all final surveying notes shall be provided before final payment to the Contractor.

Construction stakes shall be set and stationed by the Contractor at the Contractor's expense. Unless otherwise indicated in the Special Provisions, surveying costs shall be included in the price of items bid. No separate payment will be made. Re-staking and replacement of construction survey markers damaged as a result of the Work, vandalism, or accident shall be at the Contractor's expense.

2-9.1 Permanent Survey Markers

Contractor is responsible for preservation, perpetuation or both preservation and perpetuation of existing monuments that control subdivisions, tracts, boundaries, streets, highways, other rights-of-way, and easements, and those existing monuments that provide survey control, which will be disturbed or removed due to Contractor's work. Contractor shall provide a minimum of ten (10) Working Days notice to the City Engineer or Surveyor before disturbance or removal of existing monuments. The Contractor and City Engineer will coordinate schedules so that this work may be accomplished.

2-9.2 Survey Service

The line and grades for construction will be parallel to and offset from the position of work. From the established lines and grades, the Contractor shall extend the necessary lines and grades for construction of the work and shall be responsible for the correctness of same.

2-11 INSPECTION

Contractor shall arrange and pay for all off-site inspection of the Work required by any ordinance or governing authorities. The Contractor shall also arrange and pay for other inspections, including tests in connection therewith, as may be assigned or required.

SECTION 3. CHANGES IN WORK

The provision below shall supplement but not replace those provisions in Section 3 of the Standard Specifications.

To allow for inclusion of reasonable contingencies in the bid, "original quantity" shall mean the quantity shown on the Plans or as delineated in the Specifications, and not the estimated quantity shown in the Bid schedule.

3-2 CHANGES INITIATED BY THE AGENCY

The City reserves the right, without notice to the Surety, to increase or decrease the quantity of any item or portion of the Work described in the Contract Documents or the Proposal form or to alter or omit portions of the Work so described, as may be deemed necessary or expedient by the City Engineer, without in any way making the Contract void. Such increases, alterations or decreases of Work shall be considered and treated as though originally contracted for, and shall be subject to all the terms, conditions and provisions of the original Contract. The Contractor shall not claim or bring suit for damages, whether for loss of profits or otherwise, on account of any decrease, alteration or omission of any kind of Work to be done.

3-3 EXTRA WORK

New and unforeseen work will be classed as Extra Work only when the work is not covered and cannot be paid for under any of the various items or combination of items for which a Bid price appears on the Proposal form. The Contractor shall not do any Extra Work except upon written order from the City Engineer.

3-3.2.3 Markup

The Contractor's reasonable allowance for the markup shall only include the total sum of office overhead, jobsite overhead and profit for work. In any case, if the work is completed only by Contractor's own forces, the Contractor's reasonable allowance for markup shall not exceed twelve percent (12%). If the work is completed only by the subcontractor(s), the Contractor's reasonable allowance for markup shall not exceed five percent (5%). If the change order is comprised of work completed by both the Contractor and subcontractor(s), the markup shall not exceed twelve percent (12%) for the Contractor's portion of the work and five percent (5%) for the subcontractor(s) portion of the work: the sum of these parts shall constitute the markup price. After a summary of all direct costs of labor, equipment, material and markup as described above, the Contractor will be allowed a verifiable bond rate for the change order.

SECTION 4. CONTROL OF MATERIALS

The provision below shall supplement but not replace those provisions in Section 4 of the Standard Specifications.

4-1 MATERIALS AND WORKMANSHIP

The Contractor and all subcontractors, suppliers, and vendors shall guarantee that the Work will meet all requirements of this Contract as to the quality of materials, equipment and workmanship. The Contractor, at no cost to the City, shall make any repairs or replacements made necessary by defects in materials, equipment or workmanship that become evident within one (1) year after the date of recordation of the Notice of Completion. Within this one-year period, the Contractor shall also restore to full compliance with the requirements of this Contract any portion of the Work that is found by the City Engineer to not meet those requirements. The Contractor shall hold the City harmless and defend and indemnify the City from claims of any kind arising from damages due to said defects or non-compliance. The Contractor shall make all repairs, replacements, and restorations within thirty (30) Days of the date of the City Engineer's written notice, unless that notice shall require such repairs, replacements, and restorations within another time frame.

4-1.4 Test of Materials

Except as elsewhere specified, the City shall bear the cost of testing materials and workmanship that meet or exceed the requirements indicated in the Standard Specifications and the Special Provisions. The cost of all other tests, including the retesting of material or workmanship that fails to pass the first test, shall be borne by the Contractor.

4-1.6 Trade Names or Equals

If Contractor requests to substitute an equivalent item for a brand or trade name item, the burden of proof as to the comparative quality and suitability of alternative equipment or articles or materials shall be upon the Contractor, and Contractor shall furnish, at Contractor's own expense, all information necessary or related thereto as required by the City Engineer. All requests for substitution shall be submitted, together with all documentation necessary for the City Engineer to determine equivalence, within thirty-five (35) days of the date of Contract award, unless a different deadline is listed in the Special Provisions.

SECTION 5. UTILITIES

The provisions below shall supplement but not replace those provisions in Section 5 of the Standard Specifications.

5-1 LOCATION

The location and existence of any underground utility or substructure has not been obtained. The methods used and costs involved to locate existing elements, points of connection and all construction methods are Contractor's sole responsibility. Accuracy of information furnished, as to existing conditions, is not guaranteed by the City. Contractor, at his or her sole expense, must make all investigations necessary to determine locations of existing elements, which may include, without limitation, contacting U.S.A. Alert and other private underground locating firm(s), utilizing specialized locating equipment, hand trenching, or both. For every Dig Alert Identification Number issued by U.S.A. during the course of the project, Contractor must submit to the City the "Underground Service Alert Identification Number Form" attached hereto and incorporated herein by this reference. The Contractor shall be responsible for preserving the integrity of the existing underground utilities at the site.

5-1.1 Notification

The Contractor shall notify the City Engineer and the owners of all Utilities and substructures not less than forty-eight (48) hours before starting construction. The following list of names and telephone numbers is intended for the convenience of the Contractor and is not guaranteed to be complete or accurate:

Agency: City of Agoura Hills
Phone Number: (818) 597-7329
Contact Person: Mr. Robert Cortes

Agency: AT&T Maintenance Repair
Phone Number: (818) 536-4135
Contact Person: Mr. Tom Kemerling

Agency: AT&T Planning & Engineering
Phone Number: (818) 374-6411
Contact Person: Mr. Michael Osborn

Agency: Southern California Gas (Distribution)
Phone Number: (818) 700-3667

Agency: Southern California Gas (Transmission)
Phone Number: (805) 681-7928

Agency: Southern California Edison Company
Phone Number: (805) 494-7065
Contact Person: Mr. Conrado Reynado Jr.

Agency: Las Virgenes Municipal Water District
Phone Number: (818) 251-2100
Contact Person: Mr. Mike Hand

Agency: Time Warner Cable North Division/Technical Operations
Phone Number: (805) 477-4443
Contact Person: Mr. Richard Zambrano

Agency: Waste Management GI Industries
Phone Number: (818) 782-2474

Agency: Los Angeles County, Sewer Maintenance Division
Phone Number: (626)300-3308

Agency: Los Angeles County, Signal Maintenance Division
Phone Number: (626) 458-1700

5-1.2 Entry by Utility Owners

The right is reserved to the owners of public Utilities or franchises to enter upon the Project site for the purpose of making repairs or changes in their property that may be necessary as a result of the Work as well as any other reason authorized by the City. When the Contract Documents provide for the Utility owners to alter, relocate or reconstruct a Utility, or when the Contract Documents are silent in this regard and it is determined by the City Engineer that the Utility owners must alter, relocate or reconstruct a Utility, the Contractor shall schedule and allow adequate time for those alterations, relocations or reconstructions by the respective Utility owners.

5-2 PROTECTION

If Utilities become damaged or broken due to the Contractor's Work, it will be Contractor's responsibility to repair the Utility at no cost to the Utility or the City of Agoura Hills.

6 REMOVAL

Facilities encountered during the prosecution of the work that are determined to be abandoned shall be removed by the Contractor as required for the Work, unless directed otherwise by the City Engineer.

The remaining portion of the existing utility which is left in place, shall be accurately recorded, in elevation and plan, on the control set of Contract Drawings.

UNDERGROUND SERVICE ALERT IDENTIFICATION NUMBER FORM

(To be completed only by the awarded Contractor prior to excavation)

No excavation will be permitted until this form is completed and returned to the City.

Government Code Section 4216 *et seq.* requires a Dig Alert Identification Number to be issued before a permit to excavate will be valid.

To obtain a Dig Alert Identification Number, call Underground Service Alert at **811** a minimum of three (3) Working Days before scheduled excavation. For best response, provide as much notice as possible, up to ten (10) working days.

Dig Alert Identification Number: _____

Dated: _____

("CONTRACTOR")

By: _____

Printed Name: _____

Title: _____

By: _____

Printed Name: _____

Title: _____

Note: This form is required for every Dig Alert Identification Number issued by U.S.A. during the course of the Work. Additional forms may be obtained from the City upon request.

5-4 RELOCATION

The Contractor shall cooperate fully with all Utility forces of the City or forces of other public or private agencies engaged in the relocation, altering, or otherwise rearranging of any facilities that interfere with the progress of the Work. The Contractor shall schedule the Work so as to minimize interference with the relocation, altering, or other rearranging of facilities.

5-6 COOPERATION

The Contractor's attention is directed to the fact that work may be conducted at or adjacent to the site by other contractors during the performance of the Work under this Contract. The Contractor shall conduct its operations so as to cause a minimum of interference with the work of such other contractors, and shall cooperate fully with such contractors to provide continued safe access to their respective portions of the site, as required to perform work under their respective contracts. Compensation for compliance shall be included in the various items of Work, and no additional compensation shall be allowed therefor.

SECTION 6. PROSECUTION, PROGRESS AND ACCEPTANCE OF THE WORK

Subsection 6-6.4 of the Standard Specifications shall not be incorporated, and shall instead be replaced with the following:

If the Contractor desires payment for a delay as specified in Subsection 6-6.3 of the Standard Specifications, the Contractor shall notify the City Engineer in writing within three (3) Working Days after the beginning of the delay. If the Contractor desires an extension of time as specified in Subsection 6-6.2 of the Standard Specifications, the Contractor shall notify the City Engineer in writing at least three (3) Working Days before the beginning of the delay. Such notice shall specify the nature of the delay and the conditions which set the beginning time of delay. Failure by the Contractor to file these items within the times specified herein will be considered grounds for rejection by the City, regardless of the merit of the issues raised in that notice.

Additionally, Section 6-9 of the Standard Specifications shall not be incorporated, and shall instead be replaced with the following:

Failure of the Contractor to complete the Work within the time allowed will result in damages being sustained by the City and its constituents, including in some cases impairing other contracts that rely on the original completion date. Such damages are, and will continue to be, impracticable and extremely difficult to determine. For each Day in excess of the time specified for completion of the Work, as adjusted in accordance with Section 6-6 of the Standard Specifications, the Contractor shall pay to the City, or have withheld from monies due to the Contractor, the sum of five hundred dollars (\$500), unless otherwise specified in the Special Provisions.

Execution of the Contract shall constitute agreement by the City and Contractor that five hundred dollars (\$500) per Day is the minimum value of the costs and actual damage caused by the failure of the Contractor to complete the Work within the allotted time. Such sum is liquidated damages and shall not be construed as a penalty, and may be deducted from payments due to the Contractor if such delay occurs.

For the purposes of the calculation of the start of the liquidated damages, the Work herein contracted for shall be deemed to be completed when the same has been actually completed in accordance with the Plans and Specifications therefor and to the satisfaction of the City Engineer. The Project must be certified by the City Engineer in accordance with Section 6-8.1 of the Standard Specifications.

Otherwise, the provisions below shall supplement but not replace those provisions in Section 6 of the Standard Specifications.

6-1 CONSTRUCTION SCHEDULE AND COMMENCEMENT OF THE WORK

6-1.1 Construction Schedule

In addition to the construction schedule required pursuant to Section 6-1.1 of the Standard Specifications after notification of the award of the Contract and before any start of the Project, as well as the revised construction schedule in advance of beginning revised operations, Contractor shall submit an updated construction schedule with its monthly invoice every month. Progress payments shall be contingent upon the receipt of monthly updated construction schedules.

One week before the scheduled pre-construction meeting, the Contractor must submit a construction schedule to the City Engineer for review and approval. The Contractor shall make revisions as required by the City Engineer. The schedule must account for all subcontract work, as well as the work of the Contractor, submittals, coordination with the other contractors performing concurrent work and the Traffic Control Plan. The Contractor shall update the Construction Schedule when directed by the City Engineer, or when:

a. A change order significantly affects the Contract completion date or the sequence of construction approach or activities; or

b. The actual sequence of the Work, or the planned sequence of the Work, is changed and does not conform to the Contractor's current accepted project construction schedule.

6-2 PROSECUTION OF THE WORK

If the Contractor has fallen behind the accepted construction schedule by more than three percent (3%) of the total number of Working Days on the critical path for the project, the Contractor shall submit a recovery schedule to the City Engineer that exactly indicates measures of schedule recovery including, but not limited to, revised methods of procurement, revised sequencing of work, and any additional measures such as increasing the number of personnel, shifts, overtime operations, days of work, amount of construction equipment until such time as the Work is back on schedule. All cost required to bring the Project back on schedule shall be borne by the Contractor without additional cost to the City.

If the Contractor falls behind the accepted construction schedule, as modified by such time extension as may have been granted by the City for unavoidable delays, by more than thirty-five (35) percentage points based on earned progress payments, the City can deem that the Contractor is in material breach of the Contract, in which case the Work shall be turned over to the Surety for completion.

Alternatively, if the City Engineer determines that the Contractor is failing to prosecute the Work to the proper extent, the City Engineer may issue an order in any form or manner. If the order is in writing, the City Engineer has the option of listing the steps required to remedy the situation and reasonable

deadlines therefor. The City Engineer may also provide that if such steps are not taken within such listed deadlines, then an amount of five hundred dollars (\$500) per Day or whatever amount is listed in the Special Provisions may be assessed for each day of delay as a result of damages being sustained by the City that are, and will continue to be, impracticable and extremely difficult to determine. Execution of the Contract shall constitute agreement by the City and the Contractor that this amount per day is the minimum value of the costs and actual damage caused by the failure of the Contractor to prosecute the Work according to the construction schedule. Such sum is similar to liquidated damages, shall not be construed as a penalty, and may be deducted from payments due the Contractor if such delay occurs.

All parts of Section 8-1.02D (“Level 3 Critical Path Method Schedule”) of the 2010 edition of the “Caltrans Standard Specifications” are hereby incorporated into these General Provisions. Where the Caltrans Standard Specifications state “Engineer,” that term shall be interpreted to be the City Engineer. Where the Caltrans Standard Specifications state “Department,” that term shall be interpreted to be the City of Agoura Hills. Where the Caltrans Standard Specifications reference other parts of the State’s Standard Specifications, the referenced paragraphs and subsections shall also be incorporated into these General Provisions.

These options are available in addition to all other options in the Standard Specifications or as otherwise legally available.

6-5 TERMINATION OF THE CONTRACT FOR CONVENIENCE

In addition to the reasons for termination listed in Section 6-5 of the Standard Specifications, which allow termination upon any written notice, the City may cancel the Contract for any other reason or for no reason upon thirty (30) Days’ written notice. The rest of the procedure outlined in Section 6-5 shall apply to such situation, including the Contractor’s required immediate notification of Subcontractors and suppliers and the payment. In no event (including termination for impossibility or impracticability, due to conditions or events beyond the control of the City, for any other reason or for no reason) shall the total amount of money to Contractor exceed the amount which would have been paid to Contractor for the full performance of the services described in the Contract.

Furthermore, some of the City’s projects are funded in whole or in part by funds other than the City’s General Fund. If this Project is funded by such external funds in whole or in part, those external funds are terminated or reduced at any time and for any reason or for no reason at all, and the City determines at its discretion that no other funding is available for continuation of this Project, the City will not be obligated to continue funding for the services contained in these Contract Documents and may terminate the Project immediately. The City shall reimburse Contractor for its work satisfactorily completed until the termination date. In no event shall the total amount of money to Contractor exceed the amount which the City has received in funding from its external source. The Special Provisions may include further details in this regard.

6-6 DELAYS AND EXTENSIONS OF TIME

6-6.1 General

The Contractor shall not be responsible for the cost of repairing or restoring damage to the Work if the damages have been determined to have been proximately caused by an Act of God and are in excess of five percent (5%) of the Contract amount, provided that the Work damaged was built in accordance with accepted and applicable building standards and the Contract Documents. Per Section 7105(b)(2)

of the Public Contract Code, "Acts of God" shall include only earthquakes in excess of a magnitude of 3.5 on the Richter Scale and tidal waves. The Contractor shall notify the City promptly in writing of each such excusable delay, its cause and its expected delay, and shall upon request update such notice. This Section shall not abridge or affect, and shall be read in congruence with, Section 6-6 of the Standard Specifications.

No extension of time will be granted for delay caused by shortage of materials unless the Contractor furnishes to the City Engineer documentary proof that he or she has diligently made reasonable and timely efforts to obtain such materials from all known sources. No time extension will be granted for delays which do not affect the critical path of the construction schedule provided at the Pre-Construction Meeting.

Unless otherwise agreed in writing, an adjustment to the Contract time by reason of a Change Order shall be agreed to at the time the Change Order is issued and accepted by the Contractor. If the Change Order does not reserve the right of the parties, or either of them, to seek an adjustment to the Contract time, then the parties forever relinquish and waive such right and there shall be no further adjustments to the Contract time.

6-6.2 Extensions of Time

In the event it is deemed appropriate by the City to extend the time for completion of the Work, any such extension shall not release any guarantee for the Work required by the Contract Documents, nor shall any such extension of time relieve or release the sureties on the Bonds executed. In executing such Bonds, the sureties shall be deemed to have expressly agreed to any such extensions of time. The amount of time allowed by an extension of time shall be limited to the period of the delay giving rise to the same as determined by the City. Notwithstanding any dispute which may arise in connection with a claim for adjustment of the Contract time, the Contractor shall promptly proceed with the Work.

6-6.3 Payment for Delays

Notwithstanding any other terms and conditions of the Contract Documents, the City shall have no obligation whatsoever to increase the Contract Price or extend the time for delays.

Unless compensation and/or markup is agreed upon by the City, the Contractor agrees that no payment of compensation of any kind shall be made to the Contractor for damages or increased overhead costs caused by any delays in the progress of the Contract, whether such delays are avoidable or unavoidable or caused by any act or omission of the City or its agents. Any accepted delay claim shall be fully compensated for by an extension of time to complete the performance of the Work.

This Section shall not apply to compensable delays caused solely by the City. If a compensable delay is caused solely by the City, the Contractor shall be entitled to a Change Order that: 1) extends the time for completion of the Contract by the amount of delay caused by the City; and 2) provides equitable adjustment, as determined by the City, to the Contractor.

6-8 COMPLETION, ACCEPTANCE AND WARRANTY

6-8.2 Acceptance

The Project will not be considered complete and ready for City Council direction to staff regarding the

Notice of Completion until all required Work is completed, the Work site is cleaned up in accordance with Section 7-8 of the Standard Specifications, the General Provisions, and the Special Provisions, and all of the following items have been received by the City Engineer:

1. "Notice of Completion" indicating approval by City;
2. All written guarantees and warranties;
3. All "as-builts";
4. The warranty/ maintenance Bond or proof from the Surety of the extension of the performance Bond, as more specifically detailed in Section 2-4 of these General Provisions; and
5. Duplicate copies of all operating instructions and manufacturer's operating catalogs and data, together with such field instructions as necessary to fully instruct City personnel in correct operation and maintenance procedures for all equipment installed listed under the electrical, air conditioning, heating, ventilating and other trades. This data and instructions shall be furnished for all equipment requiring periodic adjustments, maintenance or other operation procedures.

The Contractor shall allow at least seven (7) Working Days notice for final inspection. Such notice shall be submitted to the Engineer in writing.

6-8.3 Warranty

For the purposes of the calculation of the start of the warranty period, the Work herein contracted for shall be deemed to be completed upon the date of recordation of the Notice of Completion. If that direction is contingent on the completion of any items remaining on a punch list, the Work herein contracted for shall be deemed to be completed upon the date of the City Engineer's acceptance of the final item(s) on that punch list.

Contractor shall repair or replace defective materials and workmanship as required in Section 6-8.3 of the Standard Specification at Contractor's own expense. Additionally, Contractor agrees to defend, indemnify and hold the City harmless from claims of any kind arising from damage, injury or death due to such defects.

The parties agree that no certificate given shall be conclusive evidence of the faithful performance of the Contract, either in whole or in part, and that no payment shall be construed to be in acceptance of any defective Work or improper materials. Further, the certificate or final payment shall not terminate the Contractor's obligations under the warranty herein. The Contractor agrees that payment of the amount due under the Contract and the adjustments and payments due for any Work done in accordance with any alterations of the same, shall release the City, the City Council and its officers and employees from any and all claims or liability on account of Work performed under the Contract or any alteration thereof.

SECTION 7. RESPONSIBILITIES OF THE CONTRACTOR

The first paragraph of Section 7-3.1 shall not be incorporated, and shall instead be replaced with the following:

The Contractor shall provide and maintain insurance naming the Agency as an insured or

additional insured with the Contractor regardless of any inconsistent statement in the policy or any subsequent endorsement whether liability is attributable to the Contractor or the Agency. The insurance provisions shall not be construed to limit the Contractor's indemnity obligations contained in the Contract. The Agency will not be liable for any accident, loss, or damage to the Work prior to completion, except as otherwise specified in 6-10.

The first sentence of Section 7-8.4.2 shall not be incorporated, and shall instead be replaced with the following:

Construction materials and equipment shall not be stored in streets, roads, or highways unless otherwise specified in the Special Provisions or approved by the Engineer.

The first sentence of the second paragraph of Section 7-9 of the Standard Specifications shall not be incorporated, and shall instead be replaced with the following:

The Contractor shall relocate, repair, replace, or reestablish all existing improvements within the Project limits which are not designated for removal (e.g., curbs, sidewalks, driveways, signal loops, fences, walls, sprinkler systems, signs, utility installations, pavements, structures, etc.) which are damaged or removed, as a result of Contractor's or subcontractors' operations or as required by the Plans and Specifications.

The last paragraph of Section 7-9 of the Standard Specifications shall not be incorporated, and shall instead be replaced with the following:

All costs to the Contractor for protecting, removing, restoring, relocating, repairing, replacing or reestablishing existing improvements shall be included in the bid.

Section 7-12 ("Advertising") of the Standard Specifications shall not be incorporated, and shall instead be replaced with the following:

The names, addresses and specialties of Contractor, Subcontractors, architects or engineers may not be displayed on any signage within the public right-of-way. This signage prohibition includes advertising banners hung from truck beds or other equipment.

Otherwise, the provisions below shall supplement but not replace those provisions in Section 7 of the Standard Specifications.

7-1 THE CONTRACTOR'S EQUIPMENT AND FACILITIES

A noise level limit of 86 dbA at a distance of 50 feet shall apply to all construction equipment on or related to the job whether owned by the Contractor or not. The use of excessively loud warning signals shall be avoided, except in those cases required for the protection of personnel.

7-2 LABOR

7-2.2.1 Public Work

Contractor acknowledges that the Project is a "public work" as defined in Division 2, Part 7, Chapter 1 (commencing with Section 1720) of the California Labor Code ("Chapter 1"), and that this Project is subject to (a) Chapter 1, including without limitation Labor Code Section 1771 and (b) the rules and

regulations established by the Director of Industrial Relations (“DIR”) implementing such statutes. Contractor shall perform all Work on the Project as a public work. Contractor shall comply with and be bound by all the terms, rules and regulations described in (a) and (b) as though set forth in full herein.

7-2.2.2 Copies of Wage Rates

Pursuant to Labor Code Section 1773.2, copies of the prevailing rate of per diem wages for each craft, classification, or type of worker needed to perform the Project are on file at City Hall and will be made available to any interested party on request. By initiating any Work on this Project, Contractor acknowledges receipt of a copy of the DIR determination of such prevailing rate of per diem wages, and Contractor shall post such rates at each job site covered by these Contract Documents.

7-2.2.3 Job Site Notices

The Contractor is required to post job site notices, as prescribed by regulation.

7-2.2.4 Failure to Pay Prevailing Rates

Contractor shall comply with and be bound by the provisions of Labor Code Sections 1774 and 1775 concerning the payment of prevailing rates of wages to workers and the penalties for failure to pay prevailing wages. The Contractor shall, as a penalty to the City, forfeit two hundred dollars (\$200) for each calendar day, or portion thereof, for each worker paid less than the prevailing rates as determined by the DIR for the work or craft in which the worker is employed for any public work done pursuant to these Contract Documents by Contractor or by any Subcontractor.

7-2.2.5 Apprentices

Contractor shall comply with and be bound by the provisions of Labor Code Sections 1777.5, 1777.6 and 1777.7 and California Administrative Code Title 8, Section 200 *et seq.* concerning the employment of apprentices on public works projects. Contractor shall be responsible for compliance with these Sections for all apprenticeable occupations. Before commencing Work on this Project, Contractor shall provide City with a copy of the information submitted to any applicable apprenticeship program. Within sixty (60) Days after concluding Work, Contractor and each of its Subcontractors shall submit to the City a verified statement of the journeyman and apprentice hours performed under this Contract.

7-2.2.6 Debarment or Suspension

Contractor and Subcontractors shall not be debarred or suspended throughout the duration of this Contract pursuant to Labor Code Section 1777.1 or 1777.7. If Contractor or any Subcontractor becomes debarred or suspended throughout the duration of the Project, Contractor shall immediately notify City.

7-2.3 Payroll Records

Contractor shall comply with and be bound by the provisions of Labor Code Section 1776, which requires Contractor and each Subcontractor to (1) keep accurate payroll records and verify such records in writing under penalty of perjury, as specified in Section 1776, (2) certify and make such payroll records available for inspection as provided by Section 1776, and (3) inform the City of the location of the records. Contractor and all Subcontractors and Sub-Tier Contractors will be required to submit weekly Certified Payroll Reports (CPRs) no later than 10- days after the weekend date of each

CPR. In addition, all Contractors and Subcontractors and Sub-Tier Contractors will be required to submit Electronic Certified Payroll Reports (eCPRs) to the DIR Labor Commissioner. Contractor has ten (10) days in which to comply subsequent to receipt of a written notice requesting these records, or as a penalty to the City, Contractor shall forfeit one hundred dollars (\$100) for each Day, or portion thereof, for each worker, until strict compliance is effectuated. Upon the request of the Division of Labor Standards Enforcement, these penalties shall be withheld from progress payments then due.

7-2.4 Hours of Labor

Contractor acknowledges that eight (8) hours labor constitutes a legal day's work. Contractor shall comply with and be bound by Labor Code Section 1810. Contractor shall comply with and be bound by the provisions of Labor Code Section 1813 concerning penalties for workers who work excess hours. The Contractor shall, as a penalty to the City, forfeit twenty-five dollars (\$25) for each worker employed in the performance of this Project by the Contractor or by any Subcontractor for each calendar day during which such worker is required or permitted to work more than eight (8) hours in any one (1) calendar day and forty (40) hours in any one calendar week in violation of the provisions of Division 2, Part 7, Chapter 1, Article 3 of the Labor Code. Pursuant to Labor Code Section 1815, work performed by employees of Contractor in excess of eight (8) hours per day, and forty (40) hours during any one week shall be permitted upon public work upon compensation for all hours worked in excess of eight (8) hours per day at not less than 1 1/2 times the basic rate of pay.

7-2.5 Registration with the DIR

In accordance with Labor Code Sections 1725.5 and 1771.1, no contractor or subcontractor shall be qualified to bid on, be listed in a bid proposal, subject to the requirements of Section 4104 of the Public Contract Code, or engage in the performance of any contract for public work, unless currently registered and qualified to perform public work pursuant to Section 1725.5.

7-2.6 Subcontractors

For every Subcontractor who will perform Work on the Project, Contractor shall be responsible for such Subcontractor's compliance with Chapter 1 and Labor Code Sections 1860 and 3700, and Contractor shall include in the written contract between it and each Subcontractor a copy of the provisions in this Section 7.2 of the General Provisions and a requirement that each Subcontractor shall comply with those provisions. Contractor shall be required to take all actions necessary to enforce such contractual provisions and ensure Subcontractor's compliance, including without limitation, conducting a periodic review of the certified payroll records of the Subcontractor and upon becoming aware of the failure of the Subcontractor to pay his or her workers the specified prevailing rate of wages. Contractor shall diligently take corrective action to halt or rectify any failure.

7-2.7 Prevailing Wage Indemnity

To the maximum extent permitted by law, Contractor shall indemnify, hold harmless and defend (at Contractor's expense with counsel reasonably acceptable to the City) the City, its officials, officers, employees, agents and independent contractors serving in the role of City officials, and volunteers from and against any demand or claim for damages, compensation, fines, penalties or other amounts arising out of or incidental to any acts or omissions listed in Section 7-2 of the General Provisions by any Person (including Contractor, its Subcontractors, and each of their officials, officers, employees and agents) in connection with any Work undertaken or in connection with the Contract Documents, including without limitation the payment of all consequential damages, attorneys' fees, and other related

costs and expenses. All duties of Contractor under this Section 7-2.6 shall survive termination of the Contract.

7-3 LIABILITY INSURANCE

The Contractor shall at all times during the term of the Contract carry, maintain, and keep in full force and effect the insurance referenced in Section 7-3 of the Standard Specifications.

7-3.1.1 Additional Insureds

The City of Agoura Hills and its elected and appointed officials, officers, employees, attorneys, agents, designated volunteers, and independent contractors in the role of City officials shall be the insured or named as additional insureds covering the Work, regardless of any inconsistent statement in the policy or any subsequent endorsement whether liability is attributable to the Contractor or the City.

7-3.1.2 No Limitation on Indemnity

The insurance provisions shall not be construed to limit the Contractor's indemnity obligations contained in these Contract Documents.

7-3.1.3 Replacement Insurance

Contractor agrees that it will not cancel, reduce or otherwise modify the insurance coverage. The Contractor agrees that if it does not keep the required insurance in full force and effect, and such insurance is available at a reasonable cost, the City may take out the necessary insurance and pay the premium thereon, and the repayment thereof shall be deemed an obligation of the Contractor and the cost of such insurance may be deducted, at the option of the City, from payments due the Contractor. This shall be in addition to all other legal options available to the City to enforce the insurance requirements.

7-3.1.4 Certificates of Insurance with Original Endorsements

The Contractor shall submit to the City certificates of insurance with the original endorsements, both of which reference the same policy number, for each of the insurance policies that meet the insurance requirements not less than one (1) day before the signing of the Contract. The endorsements are to be signed by a person authorized by that insurer to bind coverage on its behalf. Endorsements may be executed on the City's appropriate standard forms titled "Additional Insured Endorsement," copies of which are provided in the Contract Documents, or on any other form acceptable to the City. In any case, the endorsements must specifically name the City of Agoura Hills and its elected and appointed officials, officers, employees, attorneys, agents, designated volunteers, and independent contractors in the role of City officials as insureds or additional insureds. Current insurance certificates and endorsements shall be kept on file with the City at all times during the term of this contract. City reserves the right to require complete, certified copies of all required insurance policies at any time.

7-3.1.5 Subcontractors

Contractor shall ensure all Subcontractors and their employees are listed as additional insureds on all of Contractor's insurance.

7-3.2 General Liability Insurance

Instead of the minimum limits listed in Section 7-3.2 of the Standard Specifications, the coverage shall provide the following minimum limits and meet the Los Angeles County Public Works insurance requirements in Appendix G:

Insurance Coverage Requirements	Limit Requirements
Comprehensive General Liability	\$2,000,000
Products/ Completed Operations Hazard	\$2,000,000
Comprehensive Automobile Liability	\$2,000,000
Contractual General Liability	\$2,000,000

A combined single-limit policy with aggregate limits in the amount of \$3,000,000 will be considered equivalent to the required minimum limits.

7-3.3 Workers' Compensation Insurance

The workers' compensation insurance shall have a minimum limit of \$1,000,000 or the amount required by law, whichever is greater.

7-3.4 Automobile Insurance

Instead of the minimum limits listed in Section 7-3.4 of the Standard Specifications, the automobile insurance shall have a minimum limit of \$1,000,000 per claim and occurrence and \$1,000,000 in the aggregate for bodily injuries or death of one person and \$1,000,000 for property damage arising from one incident.

7-4 INDEMNIFICATION

The following indemnity provisions shall supersede the indemnity in Section 7-3 of the Standard Specifications.

7-4.1 Contractor's Duty

To the maximum extent permitted by law, Contractor hereby agrees, at its sole cost and expense, to defend with competent defense counsel approved by the City Attorney, protect, indemnify, and hold harmless the City, its elected and appointed officials, officers, employees, volunteers, attorneys, agents (including those City agents serving as independent contractors in the role of City representative), successors, and assigns (collectively "Indemnitees") from and against any and all claims (including, without limitation, claims for bodily injury, death or damage to property), demands, charges, obligations, damages, causes of action, proceedings, suits, losses, stop payment notices, judgments, fines, liens, penalties, liabilities, costs and expenses of every kind and nature whatsoever, in any manner arising out of, incident to, related to, in connection with or resulting from any act, failure to act, error or omission of Contractor or any of its officers, agents, attorneys, servants, employees, Subcontractors, material suppliers or any of their officers, agents, servants or employees, arising out of, incident to, related to, in connection with or resulting from any term, provision, image, plan, covenant, or condition in the Contract Documents, including without limitation, the payment of all consequential damages, attorneys' fees, experts' fees, and other related costs and expenses (individually, a "Claim," or collectively, "Claims"). Contractor shall promptly pay and satisfy any judgment, award or decree that may be rendered against Indemnitees in any such Claim. Contractor shall reimburse Indemnitees for any and all legal expenses and costs incurred by each of them in connection therewith or in enforcing the indemnity herein provided. Contractor's obligation to indemnify shall not be restricted to insurance

proceeds, if any, received by Contractor or Indemnitees. This indemnity shall apply to all Claims regardless of whether any insurance policies are applicable or whether the Claim was caused in part or contributed to by an Indemnitees.

7-4.2 Civil Code Exception

Nothing in this Section 7-4 shall be construed to encompass Indemnitees' sole negligence or willful misconduct to the limited extent that the underlying Contract is subject to Civil Code Section 2782(a) or the City's active negligence to the limited extent that the underlying Contract Documents are subject to Civil Code Section 2782(b), provided such sole negligence, willful misconduct or active negligence is determined by agreement between the parties or by the findings of a court of competent jurisdiction.

7-4.3 Nonwaiver of Rights

Indemnitees do not and shall not waive any rights that they may possess against Contractor because the acceptance by City, or the deposit with City, of any insurance policy or certificate required pursuant to these Contract Documents. This indemnity provision is effective regardless of any prior, concurrent, or subsequent active or passive negligence by Indemnitees and shall operate to fully indemnify Indemnitees against any such negligence.

7-4.4 Waiver of Right of Subrogation

Contractor, on behalf of itself and all parties claiming under or through it, hereby waives all rights of subrogation and contribution against the Indemnitees, while acting within the scope of their duties, from all Claims arising out of or incident to the activities or operations performed by or on behalf of the Contractor regardless of any prior, concurrent or subsequent active or passive negligence by Indemnitees.

7-4.5 Survival

The provisions of this Section 7-4 shall survive the term and termination of the Contract, are intended to be as broad and inclusive as is permitted by the law of the State, and are in addition to any other rights or remedies that Indemnitees may have under the law. Payment is not required as a condition precedent to an Indemnitee's right to recover under this indemnity provision, and an entry of judgment against a Contractor shall be conclusive in favor of the Indemnitee's right to recover under this indemnity provision.

7-5 PERMITS

Before starting any construction work, the Contractor will be required to obtain all necessary permits from the City, which may include obtaining a no fee encroachment permit for Work within the public right-of-way, as well as all other permits from all other agencies. Should this Project require construction of trenches or excavations which are five (5) feet or deeper and into which a person is required to descend, the Contractor shall obtain a Cal/OSHA permit and furnish the City with a copy before Work can commence on this Project. Contractor shall bear all cost for fees for all agencies except for the City permit fees.

The Contractor and all subcontractors shall each obtain a City Business License, and shall be licensed in accordance with State Business and Professions Code. The Contractor and all subcontractors shall bear all costs for the City's Business License.

7-7 COOPERATION AND COLLATERAL WORK

The Contractor shall be responsible for coordinating its work with the City's street sweeping, trash pick-up and street maintenance contractors, Los Angeles County Sheriff and Fire Departments, utility companies' crews, and others, when necessary. Payment for conforming to these requirements shall be included in other items of work, and no additional payment shall be made thereof.

7-8 WORKSITE MAINTENANCE

Clean-up shall be done as Work progresses at the end of each day and thoroughly before weekends. The Contractor shall not allow the Work site to become littered with trash and waste material, but shall maintain the same in a neat and orderly condition throughout the construction operation. Materials which need to be disposed shall not be stored at the Project site, but shall be removed by the end of each Working Day. If the job site is not cleaned to the satisfaction of the City Engineer, the cleaning will be done or contracted by the City and shall be back-charged to the Contractor and deducted from the Contract amount.

The Contractor shall make arrangement for storing his or her equipment and materials. The Contractor shall make its own arrangements for any necessary off-site storage or shop areas necessary for the proper execution of the Work. Approved areas within Work site may be used for temporary storage; however, the Contractor shall be responsible for obtaining any necessary permit from the City. In any case, Contractor's equipment and personal vehicles of the Contractor's employees shall not be parked on the traveled way or on any section where traffic is restricted at any time.

The Contractor shall deliver, handle, and store products in accordance with the manufacturer's written recommendations and by methods and means that will prevent damage, deterioration, and loss including theft. Delivery schedules shall be controlled to minimize long-term storage of products at site and overcrowding of construction spaces. In particular, the Contractor shall provide delivery and installation coordination to ensure minimum holding or storage times for products recognized to be flammable, hazardous, easily damaged, or sensitive to deterioration, theft, and other sources of loss.

Storage shall be arranged to provide access for inspection. The Contractor shall periodically inspect to assure products are undamaged and are maintained under required conditions.

The Contractor shall promptly remove from the vicinity of the completed Work, all rubbish, debris, unused materials, concrete forms, construction equipment, and temporary structures and facilities used during construction. Final acceptance of the Work by the City will be withheld until the Contractor has satisfactorily complied with the foregoing requirements for final cleanup of the Project site.

All costs associated with the clean-up and storage required to complete the Project shall be the sole responsibility of the Contractor.

7-8.6.2 Best Management Practices (BMPs)

Contractor will be required to meet the minimum BMPs as outlined in the "Development Construction Model Program for Stormwater Management within the County of Los Angeles." The Contractor shall submit a Best Management Practice (BMP) Plan for containing any wastewater or storm water runoff from the Project site including, but not limited to the following:

1. No placement of construction materials where they could enter storm drain system, which includes gutters that lead to catch basins.
2. Checking construction vehicles for leaking fluids.
3. Providing a controlled area for cleaning or rinse-down activities.
4. Monitoring construction activities.
5. Minimizing usage of water.
6. Providing measures to capture or vacuum-up water contaminated with construction debris.
7. Removing any construction related debris on a daily basis.
8. Protecting Work areas from erosion.
9. Street sweeping at regular intervals required to control dust, debris, sediment and erosion.

The BMP Plan must be approved by the Engineer before any Work begins. The City will monitor the adjacent storm drains and streets for compliance. Failure of the Contractor to follow the approved BMP Plan will result in immediate cleanup by City and back-charging the Contractor for all costs plus fifteen percent (15%).

The Contractor shall apply for the "Small Construction Rainfall Erosivity Waiver" as defined in the General Permit. Filing of the waiver does not relieve the Contractor of submitting a BMP Plan to be used on site during construction, nor does it relieve the Contractor from conforming to the storm water requirements of the State Water Resources Control Board. The Contractor shall complete the electronic Notice of Intent (NOI) and Sediment Risk form through the State Water Board's SMARTS system, certifying that the construction activity will take place during a period when the value of the rainfall erosivity factor is less than five. In the event that the Rainfall Erosivity Waiver is not granted by the State Water Resource Control Board, the Engineer shall be notified immediately.

7-8.6.3 Storm Water Pollution Prevention Plan (SWPPP)

7-8.6.3.1 Scope of Work and NPDES

The work under this section covers full compliance with the National Pollution Discharge Elimination System (NPDES) Permit for Construction Activities, NPDES General Permit No.CAS000002 (Order No. 2009-0009-DWQ) and implements the approved Storm Water Pollution Prevention Plan (SWPPP) during the construction period of this Project. The Contractor shall conform to the requirements of the NPDES, the Waste Discharge Requirements for the County of Los Angeles, and the Regional Water Quality Control Board for the Los Angeles Region; where there is a conflict between requirements, the most stringent requirement shall govern. The Work covered in this section covers all labor, materials, tool, equipment and incidentals necessary to provide full compliance with the stated objectives.

The Contractor shall monitor general site management and construction material management and install and maintain temporary erosion and sediment control devices to prevent storm water pollution draining into natural streams and existing storm drain systems.

If the nature of the Work requires Contractor to file a Notice of Intent and SWPPP with the State Regulatory Agency, Contractor shall do so. If this is not required, Contractor shall submit a local SWPPP and a wet weather erosion control plan during the rainy season (October 1 to April 15) to comply with City policy regarding storm water management. The Contractor shall take all necessary precautions to minimize storm water pollution and control the pollutants from entering the drainage

system as directed by the City's representative. At any point during the project, a local SWPPP is subject to change if the City determines the inadequacy of the approved SWPPP to address the pollutants of concern. Upon written notification by the City, Contractor shall submit a revised SWPPP, subject to City approval, within five (5) Working Days following notification. Failure to do so could result in a stoppage of all Work without an extension in the time for completion of the Work.

7-9 PROTECTION AND RESTORATION OF EXISTING IMPROVEMENTS

The Contractor shall mark, as approved by the City Engineer, all survey monuments, manholes, valves, substructures, or other items which are visible on the surface and will be covered by his operations. This shall be completed prior to start of that operation and approved by the City Engineer.

Where existing traffic striping, pavement markings, and curb markings are damaged, partially removed or their reflectivity reduced by the Contractor's operations, such striping or markings shall also be considered as existing improvements and the Contractor shall repaint or replace such improvements.

Relocations, repairs, replacements, or reestablishments shall be at least equal to the existing improvements and shall match such improvements in finish and dimensions unless otherwise specified.

7-10 PUBLIC CONVENIENCE AND SAFETY

The provision below shall supplement but not replace those provisions in Subsection 7-10 of the Standard Specifications.

7-10.1 Access

All construction work and traffic control shall be scheduled and constructed to provide for a minimum of inconvenience and a maximum of safety to the public vehicular and pedestrian traffic. The Contractor shall be responsible for the protection of vehicular and pedestrian traffic until the work called for in the Plans, Standard Specifications, General Provisions and Special Provisions and as directed by the Engineer is complete.

Access to street intersections, public and private parking lots, commercial businesses, residences and other public and private properties must be maintained at all times. The Contractor shall notify occupants of all affected properties with written notice at least 72 hours prior to any temporary obstruction of access. Vehicular access to property line shall be maintained at all times, except as required for construction that cannot otherwise be accomplished and for a reasonable period of time. No overnight closure of any driveway will be allowed, except as permitted by the City Engineer.

At least one 12-foot wide traffic lane shall be provided for each direction of travel on all streets at all times, except as permitted by the City Engineer. The traffic lanes shall be maintained on pavement and shall remain unobstructed.

Clearances from traffic lanes shall be 5 feet to the edge of any excavation and 2 feet to the face of any curb, pole, barricade, delineator, or other vertical obstruction.

One 4-foot wide paved pedestrian walkway shall be maintained in the parkway area on each side of all streets. The clearance from the pedestrian walkway to any traffic lane shall be 5 feet.

The Contractor's construction schedule shall allow affected people ample on-street parking within a

reasonable distance from their homes and businesses. Requests for changes in the schedule shall be submitted by the Contractor to the City Engineer for approval at least 48 hours prior to the scheduled operations on the streets affected.

"TEMPORARY NO PARKING" signs shall be posted at least 48 hours, but not more than 72 hours, in advance of commencing the work. When determined necessary by the City Engineer, the signs shall be placed no more than 150 feet apart on each side of alleys, streets and parking area and at shorter intervals if conditions warrant. Contractor shall furnish and place barricades, if necessary, for posting of signs. The Contractor shall provide the signs and will be responsible for adding the dates and hours of closure to the signs. Contractor shall remove all signs within 48 hours after the portion of the work affecting parking is accepted by the City.

7-10.2.2 Traffic Control Plan (TCP)

All Work shall require maintenance and control of traffic during the construction period. Contractor shall provide a detailed Traffic Control Plan for all phases of construction for review and shall conform to the Standard Specifications, General Provisions, Special Provisions, the latest edition of the California Edition of the Manual on Uniform Traffic Control Devices (MUTCD), the latest edition of Caltrans Standard Specifications and the latest edition of Caltrans Standard Plans and must be approved by the City Engineer before construction. The "latest edition" shall be determined by the date in which the Notice Inviting Bids is first published in the newspaper. The Traffic Control Plan shall be prepared under the supervision of and signed and stamped by a registered Professional Civil Engineer or a Traffic Engineer licensed to practice in the State of California. The Traffic Control Plan shall cover signing, flagging, detour geometric, delineation and channelization, barriers and barricades, separation of opposing traffic streams, and hours of flash operation at signalized intersection(s). The Contractor shall not commence work prior to receiving an approved Traffic Control Plan. Any delay in acquiring Traffic Control Plan approval will be at the Contractor's expense and no additional working days will be granted.

Traffic control shall be provided by a qualified traffic control company specializing with a C-31 license during the construction of the Project. Traffic control shall address parking changes as well. Before the beginning of any Work or if there are changes to the proposed TCP and after approval by the City, the qualified traffic control company staff shall complete field checks of the installed traffic control by driving through the Work area at least two (2) times to ensure the adequacy of traffic control. During any period when two-way traffic is not provided, the Contractor shall employ properly trained flaggers to control traffic through the construction zone.

Contractor shall provide and maintain steel traffic plates securely over the trench whenever required or at the end of the Working Day. The plates shall be pinned and ramped with temporary asphaltic concrete.

7-10.2.2.3 Street Closures, Detours, Barricades

Street closures will not be allowed, except as specifically permitted by the City Engineer. Additionally, all traffic lanes shall be open for public use on the days and at the time specified below:

1. Saturdays, Sundays and holidays listed in Section 10-10 of these General Provisions: 12:01 AM to 11:59 PM

2. Fridays and any day preceding holidays listed in Section 10-10 of these General Provisions: 3:00 PM to 12:59 PM
3. On all days: 7:00 AM to 9:00 AM, and 200 PM to 6:00 PM, unless otherwise stated in the Special Provisions.
4. Non-construction hours: all hours when the Contractor's employees are not physically present at the construction site actively performing construction work.

On those days and hours when closure of traffic lanes is not prohibited under the provisions of the preceding paragraph, no more than one lane may be closed at any time during construction hours. During any lane closures, type II flashing arrow boards shall be used in accordance with MUTCD.

Traffic signals shall not be placed in flash operation during the hours that traffic lanes must be kept open as defined in this Section. Under no circumstances shall traffic signals be placed under flash operation without prior approval of the City. Contractor shall contact the Engineer at least five (5) Working Days in advance to coordinate signal service, unless a different time frame is required in the Special Provisions.

All traffic control barricades, signs and devices used by the Contractor shall, as a minimum, conform with the latest version of California Manual of Uniform Traffic Control Devices (CA MUTCD). The Contractor shall take additional precautions as Contractor may find necessary under the circumstances. Should the Contractor fail to provide adequate traffic control or safety barricades, and in the event a responsible individual cannot be located or refuses to perform, the City will at its option place needed devices or engage a private firm to place and maintain said traffic control devices, which will be charged to the Contractor directly.

Advance warning signs must be provided with orange warning flags in advance of temporary stop signs. Temporary stop signs are required any time a traffic signal is dark. Temporary stop signs shall be mounted at seven feet (7') height. The Contractor shall post standard "NO STOPPING – CONSTRUCTION ZONE" signs 48 hours prior to construction, not more than fifty feet (50') apart within the Work area, showing the date and time of construction.

The Contractor shall provide advance construction notification sign(s) at each end of the Project limits seven (7) Days before the start of construction at each site. Notification signs shall include the construction start and completion dates. If signs must be posted at particular locations, those locations are specified in the Special Provisions.

7-10.3 Haul routes

Subsection 7-10.3 of the Standard Specifications shall be deleted and replaced as follows:

The Contractor must obtain the City Engineer's approval before using any haul routes. Further detail requirements for haul traffic are delineated in the Special Provisions.

7-10.5.3 Steel Plate Covers

The Contractor shall cover all openings, trenches and excavations at the end of each Work Day.

7-10.5.4 Protection of the Public

It is part of the service required of the Contractor to make whatever provisions are necessary to protect the public. The Contractor shall use foresight and shall take such steps and precautions as Contractor's operations warrant to protect the public from danger in the form of loss of life, injury or loss of property, which would result from interruption or contamination of public water supply, interruption of other public service, or from the failure of partly completed work or partially removed facilities. Unusual conditions may arise on the work which will require that immediate and unusual provisions be made to protect the public from danger or loss, or damage to life and property, due directly or indirectly to prosecution of work under this contract.

The requirements of the State Division of Industrial Safety for trenches, excavations and shoring shall apply to all aspects of this Project. Safety is stressed. Trenches, if any, shall be covered at the end of each Work Day. Any operations or situation that threatens the safety of workers or the public, including improper traffic control, shall cause the suspension of work until corrections are made.

The Contractor shall take all actions necessary to protect persons and property at the job site from any injury or damages associated with the repairs which are set forth herein. Unless otherwise specified, the Contractor shall supervise and direct the work, and shall be solely responsible for all construction methods and sequences.

7-10.5.4.1.1 Temporary Guide Markers

Temporary guide markers shall be either portable delineators or fluorescent traffic cones and shall conform to these General Provisions and any Special Provisions. Only one type of temporary guide markers shall be used at any one time. Temporary guide markers shall be placed at all locations shown on the Traffic Control Plan and at such locations as directed by the Engineer.

Temporary guide markers shall be left in place at their designated locations, maintained, repaired and replaced, if damaged, as required, until their removal is approved by the Engineer. If the temporary guide markers are damaged or are not in an upright position for any reason, said markers shall immediately be replaced or restored to their original locations in an upright position by the Contractor, 24 hours per day, 7 days per week for as long as required by the City.

The Contractor shall supply and place temporary reflective lane delineation markings for lanes on arterial streets the same day after placement of asphalt.

7-10.5.4.2 Portable Delineators

Portable delineators shall conform to Section 12-3.04 of the Caltrans Standard Specifications. The portable delineators shall be spaced as necessary for proper delineation; however, in no case shall the spacing between portable delineators exceed twenty-five feet (25') on tangents or ten feet (10') on curves.

7-10.5.4.3 Fluorescent Traffic Cones

Fluorescent traffic cones shall be new or reconditioned, and of good commercial quality flexible material suitable for the purpose intended. The outer section of the portion above the base of the cone shall be a highly pigmented fluorescent orange polyvinyl compound. The overall height of the cone shall be at least twenty-eight inches (28"). The base shall be of sufficient weight and size or shall be anchored in a manner such that the traffic cone will remain in an upright position. The fluorescent traffic cones shall

be spaced as necessary for proper delineation; however, in no case shall the spacing between fluorescent traffic cones exceed twenty-five feet (25') on tangents and ten feet (10') on curves.

7-10.5.4.4 Emergencies

Five (5) days prior to the start of construction operations, the Contractor shall notify the Sheriff's Department and Fire Department wherein the Project lies, giving the expected starting date, completion date and the name and telephone number of a responsible person who may be contacted at any hour in the event of a condition requesting immediate correction.

Whenever, in the opinion of the City Engineer, an emergency exists against which the Contractor has not taken sufficient precaution for the public safety, protection of utilities and protection of adjacent structures or property, which may be damaged by the Contractor's operations and when, in the opinion of the City Engineer, immediate action shall be considered necessary in order to protect the public or property due to the Contractor's operations under this Contract, the City Engineer will order the Contractor to provide a remedy for the unsafe condition. If the Contractor fails to act on the situation within a reasonable time period, the City Engineer may provide suitable protection to said interests by causing such work to be done and material to be furnished as, in the opinion of the City Engineer, may seem reasonable and necessary.

The cost and expense of said labor and material, together with the cost and expense of such repairs as are deemed necessary, shall be borne by the Contractor. All expenses incurred by the City for emergency repairs will be deducted from the progress payments and the final payment due to the Contractor. However, if the City does not take such remedial measures, the Contractor is not relieved of the full responsibility for public safety. The Contractor shall not be entitled to any delay claims for work stopped by the City in order to correct an unsafe traffic condition, regardless of whether or not traffic control was set up in accordance with these Special Provisions.

7-10.5.5 Public Notices

7-10.6.1 Notification to Property Owners and Businesses

In addition to notices required elsewhere in the Contract Documents, the Contractor shall notify adjacent businesses and residents at least four (4) Working Days and again two (2) Working Days in advance of beginning Work. Public notices shall be provided in the form of door hangers, flyers or both, which will include a general description of the Work and will list the days and times when traffic will be restricted and parking will not be allowed along the street scheduled for the Work. All notices shall be hand-delivered by the Contractor to adjacent residents, business, and other areas directed by the Engineer.

Temporary "No Stopping" signs shall be posted along streets affected by the work two (2) Working Days or 72 hours in advance of the need, whichever is greater. The signs shall be Western Highway Products, Inc. TR30S or approved equal. In residential areas, the signs shall be placed at a spacing not exceeding 100 feet; in non-residential areas, the sign spacing shall not exceed 200 feet. The Contractor shall provide the signs and will be responsible for adding the dates and hours of restriction to the signs, removal of the signs, and furnishing and placing of barricades, if necessary, for posting of signs. The Contractor shall remove the signs immediately when they are no longer needed.

Stopping restrictions shall be limited to the intervals between 8:30 AM and 5:00 PM to allow for parking

during the night. If, for any reason, the work is rescheduled or delayed for up to two (2) days after placement of the temporary "No Stopping" signs, the Contractor shall re-date the signs affected and re-notify the residents of the change via a new notice. If the work is delayed more than two (2) days, the Contractor shall remove the signs before 7:00 AM on the previously scheduled Work Day and place re-dated signs two days or 72 hours in advance of the rescheduled work, whichever is greater.

7-10.6.2 Residents' Complaints

It is imperative that residents' complaints be resolved expeditiously. To achieve this, the City's Project representative will inform the Contractor of the complaint verbally or in writing. The Contractor, in turn, shall contact the resident and inform the City's Project Representative within twenty-four (24) hours of the action to be taken.

7-10.6.3 Project Identification Sign

Portable changeable message signs shall be furnished as required by the Traffic Engineer. Contractor shall program messages and place in location as directed, including periodic relocations as required. Such signs shall be kept clean and in good repair by the Contractor. To the extent that the Grantee posts signage at HUD funded projects, the Grantee should ensure that HUD is identified on such signage.

7-10.6.4 Additional Required Notices

The Special Provisions may include additional required notices that relate to the specific Project.

7-15 RECYCLING OF MATERIALS

Subsection 7-15 is hereby added to the Standard Specifications as follows:

7-15.1 Recycling of Asphalt Concrete, Portland Cement Concrete, Aggregate Base, and Green Waste is Required.

The Contractor shall use an approved hauler for recycling from the list provided in Appendix B.

7-15.2 Contractor's Obligation

The City is committed to a recycling program. If available, it is the obligation of the Contractor, under this Contract, to recycle the waste material through an approved recycling plant. Records and reports of waste recycle will be submitted to the City on a regular monthly basis.

SECTION 8. FACILITIES FOR AGENCY PERSONNEL

The provisions of Section 8 of the Standard Specifications shall apply except as modified herein. No field offices for City personnel shall be required; however, City personnel shall have the right to enter upon the Project at all times and shall be admitted to the offices of the Contractor to use the telephone, desk and sanitary facilities provided by the Contractor for his or her own personnel.

SECTION 9. MEASUREMENT AND PAYMENT

The provisions below shall supplement but not replace those provisions in Section 9 of the Standard Specifications.

9-1.2 Measurement

Thus, the Contract Price shall constitute full compensation for all labor, equipment, materials, tools and incidentals required to complete the Project as outlined in these Contract Documents and as directed by the Engineer.

9-3 PAYMENT

9-3.1 General

In accordance with Public Contract Code Section 7107, if no claims have been filed and are still pending, the amount deducted from the final estimate and retained by the City will be paid to the Contractor except such amounts as are required by law to be withheld by properly executed and filed notices to stop payment, or as may be withheld for any other lawful purposes.

9-3.2 Partial and Final Payment

9-3.2.1 Monthly Closure Date and Invoice Date

In accordance with Section 9-3.2 of the Standard Specifications, the monthly closure date shall be the last calendar day of each month. A measurement of Work performed and a progress estimate of the value thereof based on the Contract and of the monthly payment shall be prepared by the Contractor and submitted to the City Engineer before the tenth day of the following month for verification and payment consideration.

9-3.2.2 Payments

City shall make payments within thirty (30) Days after receipt of Contractor's undisputed and properly submitted payment request, including an updated construction schedule pursuant to Section 6-1.1 of the General Provisions. City shall return to Contractor any payment request determined not to be a proper payment request as soon as practicable, but not later than seven (7) Days after receipt, and shall explain in writing the reasons why the payment request is not proper.

9-3.3.3 Retention

The City shall withhold not less than five percent (5%) of the Contract Price until final completion and acceptance of the Project. However, at any time after fifty percent (50%) of the Work has been completed, if the City Council of the City finds that satisfactory progress is being made, it may, at its discretion, make any of the remaining progress payments in full for actual Work completed.

9-3.3.4 Final Invoice and Payment

Whenever in the opinion of the City Engineer the Contractor shall have completely performed the Contract, the City Engineer shall notify the City Clerk that the Contract has been completed in its entirety. The Contractor shall then submit to the City Engineer a written statement of the final quantities of Contract items for inclusion in the final invoice. Upon receipt of such statement, the City Engineer shall check the quantities included therein and shall authorize a payment amount, which in the City

Engineer's opinion shall be just and fair, covering the value of the total amount of Work done by the Contractor, less all previous payments and all amounts to be retained under the provisions of the Contract Documents ("Final Payment Amount"). The City Engineer shall then request that the City accept the Work and that the City Clerk be authorized to file, on behalf of the City in the office of the County Recorder, a Notice of Completion of the Work herein agreed to be done by the Contractor. In addition, the final payment will not be released until the Contractor returns the control set of Plans and Specifications showing the redlined as-built conditions. Release of retention will not be released until a formal written Clearance Letter is issued by the Community Development Commission of the County of Los Angeles (LACDC).

9-3.3.5 Substitute Security.

In accordance with Public Contract Code Section 22300, the Contractor may request that it be permitted to substitute securities in lieu of having retention withheld by the City from progress payments when such payments become due or, in the alternative, Contractor may request that the City make payments of earned retentions directly to an agreed upon designated escrow agent at Contractor's expense. If the Contractor selects either one of these alternatives, the following shall control:

9-3.3.5.1 Substitution of Securities for Performance Retention

At some reasonable time before any progress payment would otherwise be due and payable to Contractor in the performance of Work under these Contract Documents, the Contractor may submit a request to the City in writing to permit the substitution of retentions with securities equivalent to the amount estimated by the City ("estimated amount of retention") to be withheld. Contractor shall deposit such securities with the City or may, in the alternative, deposit such securities in escrow with a State or federally chartered bank in California, as the escrow agent, and at the Contractor's expense. Such securities will be the equivalent or greater in value of the estimated amount of retention. If the Contract is modified by written Modifications or Change Orders or Contractor otherwise becomes entitled to receive an amount more than the Contract amount at the time the securities are deposited, the Contractor shall, at the request of the City, deposit with the City or escrow agent, whichever is applicable, additional securities within a reasonable time so that the amount of securities on deposit with the City or escrow agent is equivalent or greater in value than the amount of retention the City would otherwise be entitled to withhold from progress payments due or to become due to the Contractor as the Work progresses. The City shall withhold any retention amount that exceeds the security amount until the additional securities are deposited and, if the deposit is with an escrow agent, the City has confirmation from that escrow agent of the new total value of securities. Upon satisfactory completion of the Contract, which shall mean, among other things, that the City is not otherwise entitled to retain proceeds from progress payments as elsewhere provided in the Contract or under applicable law, the securities shall be returned to the Contractor. The City shall, within its sole discretion, determine whether the amount of the securities on deposit with the City or escrow agent is equal to or greater than the amount of estimated retention of progress payments which could otherwise be held by the City if the Contractor had not elected to substitute same with securities.

9-3.3.5.2 Deposit of Retention Proceeds with an Escrow Agent

As an alternative to the substitution of securities, as provided above, or the City otherwise retaining and holding retention proceeds from progress payments, the Contractor may request the City to make payments of retentions earned directly to an escrow agent with the same qualifications as required in paragraph (1) above and at the expense of the Contractor. At its sole expense, the Contractor may direct the investment of such retention payments into only such securities as mentioned in paragraph

(3) below and shall be entitled to interest earned on such investments on the same terms provided for securities deposited by Contractor. Upon satisfactory completion of the Contract, which shall mean when the City would not otherwise be entitled to withhold retention proceeds from progress payments had the Contractor not elected to have such proceeds deposited into escrow, Contractor shall be allowed to receive from the escrow agent all securities, interest and payments deposited into escrow pursuant to the terms of this Section. The Contractor shall pay to each Subcontractor, not later than ten (10) Days of receipt of payment, the respective amount of interest earned, net of costs attributed to retention withheld from each Subcontractor, on the amount withheld to insure performance of the Contractor.

9-3.3.5.3 Subcontractor Entitlement to Interest

Any Contractor who elects to receive interest on moneys withheld in retention by the City shall, at the request of any Subcontractor performing more than five percent (5%) of the Contractor's total Bid, make that option available to the Subcontractor regarding any moneys withheld in retention by the Contractor from the Subcontractor. If the Contractor elects to receive interest on any moneys withheld in retention by the City, then the Subcontractor shall receive the identical rate of interest received by the Contractor on any retention moneys withheld from Subcontractor by the Contractor, less any actual pro rata costs associated with administering and calculating that interest. In the event that the interest rate is a fluctuating rate, the rate for the Subcontractor shall be determined by calculating the interest rate paid during the time that retentions were withheld from the Subcontractor. If the Contractor elects to substitute securities in lieu of retention, then, by mutual consent of the Contractor and Subcontractor, the Subcontractor may substitute securities in exchange for the release of moneys held in retention by the Contractor. The Contractor shall pay each Subcontractor, not later than ten (10) Days after receipt of escrow moneys, the amount owed to each Subcontractor from the moneys plus the respective amount of interest earned, net of costs attributed to the retention held from each Subcontractor, on the amount of retention withheld to insure performance of the Subcontractor.

9-3.3.5.4 Securities Eligible for Investment

Securities eligible for investment shall include those listed in California Government Code Section 16430, bank or savings and loan certificates of deposit, interest-bearing demand deposit accounts, standby letters of credit, or any other security mutually agreed upon between the Contractor and the City. The Contractor shall be the beneficial owner of any securities substituted for any monies withheld and shall receive any interest thereon.

9-3.3.5.5 Escrow Agreement for Security Deposits in Lieu of Retention

The escrow agreement that shall be used for the deposit of securities in lieu of retention shall substantially conform to the form prescribed in California Public Contract Code Section 22300(f).

9-3.3.5.6 Inconsistencies with Prevailing Statutory Requirements

If there is any inconsistency between or differences in Public Contract Code Section 22300 and the terms of this provision, or any future amendments thereto, Section 22300 shall control.

9-4 AUDIT

The City or its representative shall have the option of inspecting and/or auditing all records and other written materials used by Contractor in preparing its billings to the City as a condition precedent to any

payment to Contractor or in response to a construction claim or a Public Records Act request. Contractor will promptly furnish documents requested by the City at no cost. Additionally, Contractor shall be subject to State Auditor examination and audit at the request of the City or as part of any audit of the City, for a period of three (3) years after final payment under the Contract. Contractor shall include a copy of this Section 9-4 in all contracts with its subcontractors, and Contractor shall be responsible for immediately obtaining those records or other written material from its subcontractors upon a request by the State Auditor or the City. If the Project includes other auditing requirements, those additional requirements will be listed in the Special Provisions.

SECTION 10. ADDITIONAL TERMS

10-1 DEBARRED OR SUSPENDED SUBCONTRACTORS

Contractor shall not perform Work with any Subcontractor that has been debarred or suspended pursuant to California Labor Code Section 1777.1 or 1777.7.

10-2 NONDISCRIMINATORY EMPLOYMENT

Contractor shall not unlawfully discriminate against any individual based on race, color, religion, nationality, gender, sex, sexual orientation, age or condition of disability. Contractor understands and agrees that it is bound by and will comply with the nondiscrimination mandates of all statutes and local ordinances and regulations.

10-3 NOTICE TO PROCEED

Upon award of this Contract and signing the Contract Documents, the City shall issue the Contractor a Notice to Proceed. The City will not authorize any Work to be done under these Contract Documents before the Contract has been fully executed. Any Work that is done by the Contractor in advance of such time shall be considered as being done at Contractor's own risk and responsibility, and as a consequence will be subject to rejection.

10-4 CONTRACTOR'S RESPONSIBILITY FOR WORK

Until the final acceptance of the Work by the City as defined in Section 6-8.2 of the General Provisions, by written action of the City Engineer, the Contractor shall have the charge and care thereof and shall bear the risk of injury or damage to any part of the Work by the action of the elements or any other cause. The Contractor shall rebuild, repair, restore and make good all injuries or damages to any portion of the Work occasioned by any cause before its completion and acceptance and shall bear the expense thereof, except for such injuries or damages arising from the sole negligence of willful misconduct of the City, its officers, agents or employees. In the case of suspension of Work from any cause whatever, the Contractor shall be responsible for all materials and the protection of Work already completed, shall properly store and protect them if necessary, and shall provide suitable drainage and erect temporary structures where necessary.

10-5 PROCEDURE IN CASE OF DAMAGE TO PUBLIC PROPERTY

Any portions of curb, gutter, sidewalk or any other City improvement damaged by the Contractor during the course of construction shall be replaced by the Contractor at Contractor's own cost. The cost of additional replacement of curb, gutter or sidewalk in excess of the estimated quantities shown in the Proposal form and specifications, and found necessary during the process of construction (but not due

to damage resulting from carelessness on the part of the Contractor during Contractor's operation), shall be paid to the Contractor at the unit prices submitted in his or her Bid.

10-6 REMOVAL OF INTERFERING OBSTRUCTIONS

The Contractor shall remove and dispose of all debris, abandoned structures, tree roots and obstructions of any character met during the process of excavation. It is understood that the cost of any such removals are made a part of the unit price bid by the Contractor under the item for excavation or removal of existing Work.

10-7 SOILS ENGINEERING AND TESTING

A certified materials testing firm may be retained by the City to perform materials tests during the Contractor's entire operation to ascertain compliance with the contract requirements. The City shall be responsible for the first series of tests. If the initial tests do not meet the Contract requirements, the Contractor shall bear the cost of all subsequent tests.

If the City requires other tests or more specific requirements for testing regarding this Project, those details will be included in the Special Provisions.

10-8 BARRICADING, PROTECTION AND TRAFFIC CONTROL

Due to the Project's location, the Contractor shall be required to secure and render safe the entire construction area at the end of each Working Day. Work areas must be well barricaded and flagged. No open excavations will be allowed on the weekends.

Contractor shall be responsible for and shall provide and maintain all required guards, railings, lights and warning signs and shall take all precautions to avoid injury or damage to any person or property and shall protect and indemnify the City against any claim or liability arising from or based on the lack of proper safeguards or negligence whether by him- or herself or his or her agents, employees or Subcontractors.

Payment for barricading, protection and traffic control shall be included in the price bid and shall include all labor and material necessary to adequately perform the Work involved to the satisfaction of the City Engineer.

10-9 ACCESS TO PRIVATE PROPERTY

Unless otherwise stated in the Special Provisions, the Contractor shall be responsible for all fees and costs associated with securing permission to access private property for any portion of the Project.

10-10 WORKING DAYS AND HOURS

Contractor shall do all Work between the hours of 7:00 a.m. to 4:00 p.m., Monday through Friday. No Work will be allowed on Saturdays, Sundays or City holidays, which are as follows:

New Year's Day

Martin Luther King

President's Day

Memorial Day
Independence Day
Labor Day
Veteran's Day
Thanksgiving Day
Day After Thanksgiving
Christmas Eve
Christmas Day
New Year's Eve

In addition, no Work will be allowed on any special election day which may be declared. Should a special election day be declared, a time extension of one (1) Working Day will be granted for each such day.

A permit may have other hours or Days for the Contractor to do the Work, and those hours and Days shall supersede any hours and Days written in this Section.

Whenever the Contractor is permitted or directed to perform night Work or to vary the period during which Work is performed during the Working Day, Contractor shall give twelve (12) hour notice to the Inspector so that inspection may be provided. Also, a charge may be made to the Contractor for approved overtime or weekend inspections requested by the Contractor.

10-11 CLAIM DISPUTE RESOLUTION

In the event of any dispute or controversy with the City over any matter whatsoever, Contractor shall not cause any delay or cessation in or of Work, but shall proceed with the performance of the Work in dispute. Contractor shall retain any and all rights provided that pertain to the resolution of disputes and protests between the parties. The Disputed Work will be categorized as an "unresolved dispute" and payment, if any, shall be as later determined by mutual agreement or a court of law. Contractor shall keep accurate, detailed records of all Disputed Work, claims and other disputed matters.

All claims arising out of or related to the Contract Documents or this Project, and the consideration and payment of such claims, are subject to the Government Claims Act (Government Code Section 810 et seq.) with regard to filing claims. All such claims are also subject to Public Works Contract Code Sections 9204 and Public Contract Code Section 20104 et seq. (Article 1.5), where applicable. This Contract hereby incorporates those provisions as though fully set herein. Thus, the Contractor or any Subcontractor must file a claim in accordance with the Government Claims Act as a prerequisite to filing a construction claim in compliance with Section 9204 and Article 1.5 (if applicable), and must then adhere to Article 1.5 and Section 9204, as applicable, pursuant to the definition of "claim" as individually defined therein.

10-12 THIRD PARTY CLAIMS

City shall have full authority to compromise or otherwise settle any claim relating to the Project at any time. City shall timely notify Contractor of the receipt of any third-party claim relating to the Project. City shall be entitled to recover its reasonable costs incurred in providing this notice.

10-13 COMPLIANCE WITH LAWS

Contractor shall comply with all applicable federal, State and local laws, ordinances, codes and regulations in force at the time Contractor performs pursuant to the Contract Documents.

10-14 CONTRACTOR'S REPRESENTATIONS

By signing the Contract, Contractor represents, covenants and agrees that: a) Contractor is licensed, qualified, and capable of furnishing the labor, materials, and expertise necessary to perform the services in accordance with the terms and conditions set forth in the Contract Documents; b) there are no obligations, commitments, or impediments of any kind that will limit or prevent its full performance under the Contract Documents; c) there is no litigation pending against Contractor, and Contractor is not the subject of any criminal investigation or proceeding; and d) to Contractor's actual knowledge, neither Contractor nor its personnel have been convicted of a felony.

10-15 CONFLICTS OF INTEREST

Contractor agrees not to accept any employment or representation during the term of the Contract or within twelve (12) months after acceptance as defined in Section 6-8.2 of the General Provisions that is or may likely make Contractor "financially interested," as provided in Government Code Section 1090 and 87100, in any decisions made by City on any matter in connection with which Contractor has been retained pursuant to the Contract Documents.

10-16 APPLICABLE LAW

The validity, interpretation, and performance of these Contract Documents shall be controlled by and construed under the laws of the State of California, excluding California's choice of law rules. Venue for any such action relating to the Contract shall be in the Los Angeles County Superior Court.

10-17 TIME

Time is of the essence in these Contract Documents.

10-18 INDEPENDENT CONTRACTOR

Contractor and Subcontractors shall at all times remain, as to the City, wholly independent contractors. Neither the City nor any of its officials, officers, employees or agents shall have control over the conduct of Contractor, Subcontractors, or any of their officers, employees, or agents, except as herein set forth, and Contractor and Subcontractors are free to dispose of all portions of their time and activities which they are not obligated to devote to the City in such a manner and to such Persons that the Contractor or Subcontractors wish except as expressly provided in these Contract Documents. Contractor and Subcontractors shall have no power to incur any debt, obligation, or liability on behalf of the City, bind the City in any manner, or otherwise act on behalf of the City as agents. Contractor and Subcontractors shall not, at any time or in any manner, represent that they or any of their agents, servants or employees, are in any manner agents, servants or employees of City. Contractor and Subcontractors agree to pay all required taxes on amounts paid to them under the Contract, and to indemnify and hold the City harmless from any and all taxes, assessments, penalties, and interest asserted against the City by reason of the independent contractor relationship created by the Contract Documents. Contractor shall include this provision in all contracts with all Subcontractors.

10-19 CONSTRUCTION

In the event of any asserted ambiguity in, or dispute regarding the interpretation of any matter herein, the interpretation of these Contract Documents shall not be resolved by any rules of interpretation providing for interpretation against the party who causes the uncertainty to exist or against the party who drafted the Contract Documents or who drafted that portion of the Contract Documents.

10-20 NON-WAIVER OF TERMS, RIGHTS AND REMEDIES

Waiver by either party of any one or more of the conditions of performance under these Contract Documents shall not be a waiver of any other condition of performance under these Contract Documents. In no event shall the making by the City of any payment to Contractor constitute or be construed as a waiver by the City of any breach of covenant, or any default which may then exist on the part of Contractor, and the making of any such payment by the City shall in no way impair or prejudice any right or remedy available to the City with regard to such breach or default.

10-21 TERM

The Contract is effective as of the Effective Date listed, and shall remain in full force and effect until Contractor has fully rendered the services required by the Contract Documents or the Contract has been otherwise terminated by the City. However, some provisions may survive the term listed within this Section, as stated in those provisions.

10-22 NOTICE

Except as otherwise required by law, any notice or other communication authorized or required by these Contract Documents shall be in writing and shall be deemed received on (a) the day of delivery if delivered by hand or overnight courier service during the City's regular business hours or (b) on the third business day following deposit in the United States mail, postage prepaid, to the addresses listed on Contractor's Bid and City Hall, or at such other address as one party may notify the other.

10-23 SEVERABILITY

If any term or portion of these Contract Documents is held to be invalid, illegal, or otherwise unenforceable by a court of competent jurisdiction, the remaining provisions of these Contract Documents shall continue in full force and effect.

SPECIAL PROVISIONS

700 RESPONSIBILITIES OF THE CONTRACTOR

SCOPE OF WORK

The Contractor shall comply with the general responsibilities and administrative requirements as specified in the Standard Specifications for Public Works Construction (SSPWC), latest edition, all supplements, the Plans and these Special Provisions.

The Work to be performed under this Contract shall consist of furnishing all plant, tools, equipment, materials, supplies and manufactured articles for the Project. It shall also include the furnishing of all transportation and services, including fuel, power, water and essential communications, and for the performance of all labor, work, or other operations required for the fulfillment of the Contract in strict accordance with the Contract documents.

The Project includes, without limitation, furnishing all necessary labor, materials, equipment and other incidental and appurtenant Work necessary for the **removal & hauling of existing asphalt, concrete, dirt, roots, equestrian fencing and grass as necessary to construct curb access ramps, two concrete driveway approaches, 5" thick access sidewalk, 6 inch thick & 6 feet wide decomposed granite path, remove existing cross-walk striping and re-stripe cross-walk on east side of the Flood Control Channel bridge, construct pile foundation for pedestrian bridge, provide equipment to unload and install a pre-fabricated 64 feet long by 10 feet wide steel pedestrian bridge by Excel Bridge Manufacturing Company or approved equal** as more clearly described in the Contract Documents.

700-1 LOCATION OF WORK

The Work to be constructed is within the City of Agoura Hills, California, and the locations is as follows:

1. Old Agoura Park, 5400 Colodny Dr, City of Agoura Hills, CA 91301.

700-2 TIME OF COMPLETION AND START OF WORK

Unless the City approves an extension, all work shall be completed within 45 working days from the date the Notice to Proceed is issued by the Engineer, exclusive of maintenance periods. Time stated for contract completion shall include final cleanup of the premises.

700-3 EMERGENCY INFORMATION

The Contractor shall provide the following information in writing and submit it with the signed contract, contract bonds and certificates of insurance. Failure to comply may result in delays in the processing of the contract documents.

- (1) Name of authorized representative at the job site;
- (2) Address and telephone number where the above person can be reached 24 hours a day.
- (3) Address of the nearest office of the Contractor, if any, and telephone number of a person at the office who is familiar with the project.
- (4) Address and telephone number of the Contractor's main office and the name and telephone number of the person at the office familiar with the project.

700-4 PREFACE – STANDARD SPECIFICATION AND STANDARD DRAWINGS

The Standard Specifications of the AGENCY are contained in the 2015 Edition, including all current supplements, of the Standard Specifications for Public Works Construction, as written and promulgated by the Joint Cooperative Committee of the Southern California Chapter of the American Public Works Association and the Southern California District of the Associated General Contractors of California, and these modifications thereto. Copies of these Standard Specifications are available from the publisher, Building News, Incorporated, 10801 National Blvd., Ste. 100, Los Angeles, California 90064, telephone (310) 474-7771. All traffic work, including but not limited to signing and striping, traffic controllers, modification of cabinets to accept new controllers, GPS units, and traffic loops shall also comply with the latest edition of SSS and SSP, and manufacturer.

The Standard Specifications set forth above will control the general provisions, construction materials, and construction methods for this contract, except as amended by the Plans, Special Provisions, or other contract documents. The following provisions are supplementary and in addition to the provisions of the Standard Specifications unless otherwise noted and the section numbers of these provisions coincide with those of the said Standard Specifications. Only those sections requiring elaboration, amendments, specifying of options or additions are called out.

700-5 EMERGENCY INFORMATION

The names, addresses, and telephone numbers of the Contractor, subcontractors, or their representatives, shall be filed with the Engineer prior to the preconstruction meeting.

The Contractor shall provide the following information in writing and submit it with the signed contract, contract bonds and certificates of insurance. Failure to comply may result in delays in the processing of the contract documents.

- (1) Name of authorized representative at the job site;
- (2) Address and telephone number where the above person can be reached 24 hours a day;
- (3) Address of the nearest office of the Contractor, if any, and the name and telephone number of a person at that office who is familiar with the project; and
- (4) Address and telephone number of the Contractor's main office and the name and telephone number of the person at that office familiar with the project.

700-6 PROTECTION OF SURVEY MONUMENTS

The Contractor shall protect existing survey monuments and ties, if any exist within the work limits, during the entire project. In the event a surveyed monument lies within the project area, the Contractor shall tie out, reset, and file corner records per the LA County Surveyor's office requirements for re-establishing survey monuments.

700-7 SUBMITTALS

A. General

Whenever submittals are required hereunder, all such submittals by the Contractor shall be submitted to the Engineer. A Submittal is defined as any drawing, calculation, specification, product data, samples, manuals, requests for substitutes, spare parts, photographs, survey data, traffic control plans, record drawings, bonds or similar items required to be submitted to the City of the Engineer under the terms of the contract.

The Contractor shall submit two (2) copies of each submittal and allow at least ten (10) working days for review by the City.

B. Submittals Prior to Preconstruction Meeting

The Contractor shall provide the following submittals prior to the preconstruction meeting:

- (1) Insurance, Bonds and Agreement
- (2) Project Schedule, work sequence, and when property and business owners will be affected by the proposed construction
- (3) Emergency Contact List
- (4) List of Subcontractors
- (5) Public Notices

C. Submittals Prior to Start of Construction

The Contractor shall provide the following submittals prior to start of construction:

1. List of existing survey monuments/ties to be protected or re-set (if any)
2. Decomposed Granite, Aggregate Base, and Binder Material Mix Data
3. Concrete Mix & Steel Reinforcement data
4. Truncated Domes brand and specifications.
5. AC Asphalt Mix Data
6. Storm Water Pollution Prevention Plan (SWPPP)
7. Name of approved hauler for recycling materials during the project's construction

D. Engineer's Review.

The Engineer's review of Contractor submittals shall not relieve the Contractor of the entire responsibility for the correctness of details, data and dimensions. The Contractor shall assume all responsibility and risk for any misfits due to any errors in Contractor submittals. The Contractor shall be responsible for the dimensions and the design of adequate connections and details.

700-8 PROJECT MEETINGS

Preconstruction Meeting. A preconstruction conference will be held prior to the commencement of the construction at a place and time designated by the Engineer. The attendees shall include the Engineer, Contractor's representatives, including superintendent and its subcontractors, utility representatives, and other affected parties. Among the primary points of discussion at this meeting, will be the Contractor's proposed construction schedule, traffic control plans and public convenience and notice.

Progress Meetings. The Contractor shall schedule and hold regular onsite progress meetings at least weekly and at other times, as requested by the Engineer or as required by the progress of the Work. The Contractor, Engineer, and all subcontractors active on the site shall be represented at each meeting. Contractor may, at its discretion, request attendance by representatives of its suppliers, manufacturer's, and other subcontractors.

Safety Meetings. The Contractor shall notify the Engineer of all proposed safety meetings. The Engineer will advise the Contractor about contract-related safety information, safety meetings, and safety-related issues.

700-9 COORDINATION

The Contractor shall be responsible for all Project coordination and the coordination of the work of all subcontractors, fabricators, and suppliers. Coordination, as referred to herein, shall include the establishment of on-site lines of authority and communication and the scheduling of and conducting of

progress meetings between the Engineer and the Contractor and its subcontractors, fabricators, and suppliers. The Contractor's onsite supervisory person shall be present and shall represent the General Contractor whenever a meeting is held that involves any interface between the Engineer or the City and any subcontractors, fabricators, or suppliers.

The Contractor shall be responsible for coordination of the work of each of its subcontractors and suppliers. Special attention is directed to the following obligations of the Contractor:

- (1) Verify that subcontractors have obtained permits for inspections;
- (2) Review all subcontractor shop drawings, product data, and sample submittals for compliance with Contract Documents prior to submittal to the Engineer for general review for compliance with design intent;
- (3) Maintain onsite documentation and keep current record drawing set at Project site; and
- (4) Verify that specified cleaning is done during progress of Work and at completion of each subcontract.
- (5) Verify that all sub-contractors have the appropriate license(s) to complete the portion of their work.
- (6) Verify that all sub-contractors have a valid registration with the Department of Industrial Relations (DIR).

700-10 INVESTIGATION OF SITE CONDITIONS

Bidders are required to inspect the site of the work in order to satisfy themselves, by personal examination or by such other means as they may prefer, of the location of the proposed work, measurements and as to the actual conditions of and at the site of the work. If, during the course of his examination, a bidder finds facts or conditions which appear to him to conflict with the contract documents, he shall submit a letter to the Engineer requesting information and an explanation before submitting his bid. If the bidder chooses not to visit the site or conduct investigations, the bidder will, nevertheless, be charged with the knowledge of conditions, which reasonable inspection and investigation would have disclosed.

The submission of a proposal by the contractor shall constitute the acknowledgment that, if awarded the contract, he has relied and is relying on his own examination of (a) the site of the work, (b) the access to the site, (c) the slope and alignment of each street in the project area, and (d) all other data, matters, and things requisite to the fulfillment of the work and on his own knowledge of existing services and utilities on and in the vicinity of the site of the work to be constructed under the contract, and not on any representation or warranty of the Owner. No claim for additional compensation will be allowed which is based upon a lack of knowledge of the above items.

700-11 SUGGESTIONS TO CONTRACTOR

Any plan or method of work suggested by the City, Agent, or Engineer to the Contractor but not specified or required, if adopted or followed by the Contractor in whole or in part, shall be used at the risk and responsibility of the Contractor; and the City, Agent, and Engineer shall assume no responsibility therefore and in no way be held liable for any defects in the work which may result from or be caused by the use of such plan or method of work.

1. MOBILIZATION

GENERAL

Mobilization shall consist of preparatory work and operations including, but not limited to: insurance bonds, required permits and fees, shop drawings, submittals, the movement of personnel, equipment, supplies and incidentals to the project site (mobilization), as-built plans, coordination with other contractors, meetings, moving off the project and clean up. Mobilization shall additionally include the establishment of any temporary facilities, the submittal of a detailed construction schedule and the storm water pollution prevention plan (SWPPP).

Any other costs of work in advance of construction operations and not directly attributable to any specific bid item shall be included in the item mobilization.

Execution

Contractor is responsible for securing a project mobilization/staging area. Contractor shall provide Engineer with plan for utilization of mobilization/staging at time of submittal of project schedule, including any additional traffic signage and fencing details, and site access and safety considerations.

Staging Areas

Contractor is advised of the necessity to restrict his/her activities only to those staging areas and work areas shown on the Plans, or proposed by Contractor, unless otherwise authorized by Engineer. Contractor is to make arrangements for staging on adjacent private property, as required. All disturbed and damaged areas must be repaired by Contractor.

Clearing and Grubbing

This work item is for the clearing and removal of vegetation and incidental debris (rubble, garbage, etc.) necessary for site preparation. All debris shall be disposed of properly at approved landfill or other approved facility. The work includes the removal of several small trees.

Contractor is to verify trees to be removed, and tag trees for approval by Engineer. All necessary pruning and tree removal shall be done in a professional manner. Pruning on trees that are to remain shall be done with care to avoid damage to the tree. Contractor is responsible for disposal of all trees including tree trimming.

Contractor shall inspect the site and be familiar with the requirements and growth habits of existing plant material to be trimmed or removed. Contractor shall provide and maintain all equipment necessary to properly complete the pruning or tree removal work. For reconstructed slopes, tree removal includes the root-wad. Equipment shall be safe and efficient, and all cutting blades shall be kept clean and properly sharpened to avoid spread of disease. All equipment shall be equipped with required safety devices. Engineer shall be notified 48-hours prior to tree removal.

Tree pruning shall be done using accepted practices and trees shall not be "headed" or "hedged" which alters the natural form of the tree. Where possible, remove branches at the main trunk beyond branch bark ridges. Stub cuts are not acceptable. When pruning, make sure that pruning cuts are balanced so that the stability of the tree is not jeopardized. Minimize all pruning cuts to avoid unnecessary damage to vegetation.

Access and Maintaining Access

No area within the contract limits is available for the exclusive use of Contractor. Use of Contractor's work areas and any mobilization areas shall be at Contractor's own risk, and the property owner shall not be held liable for any damage or loss of materials or equipment located within such areas.

Contractor shall take care to minimize pavement damage. Construction entrances and new temporary access roads and storage areas including fencing shall be constructed as necessary. New access roads, storage areas, fencing and construction entrances shall only be permitted in locations shown on the Plans, or as approved by Engineer.

Avoidance of Sensitive Areas

Contractor shall mark the boundaries of the designated work areas with a fixed and continuous temporary barrier consisting of silt/bio fencing or other material as approved by Engineer that will prevent disturbance by Contractor's equipment and activities outside of work areas. The temporary barrier shall remain in place for the duration of the project, to avoid creek disturbance and intrusion into private property outside of work zones, beyond the limit of work.

All banks adjacent to work areas shown on the Plans shall be protected from erosion to assure that any earthwork or site grading minimizes disturbance to the creek area. Silt fences and/or other erosion control measures shall be used at strategic points at all times to assure that the creek is not impacted by construction activities.

Contractor shall conform to the protocols established in this document to ensure the avoidance of disturbance to endangered species that may inhabit the job site. These protocols shall be observed and coordinated with Engineer with appropriate procedures submitted prior to creek work.

Construction Area Signs

Construction area signs shall be furnished, installed, maintained, and removed when no longer required.

Two (2) project signs with a minimum dimension of 3 ft x 4 ft x 1/2 inch plywood and bolted to two 4 x 4 posts shall be furnished and installed by Contractor at the site. Letter and numbers shall be black on a white background. The sign information shall be as shown below:

DO NOT DISTURB

CDBG OLD AGOURA PARK ACCESSIBILITY IMPROVEMENTS PROJECT

FUNDED WITH U.S. DEPARTMENT OF HOUSING AND URBAN DEVELOPMENT (HUD)
COMMUNITY DEVELOPMENT BLOCK GRANT (CDBG) FUNDS

Expected Completion Date: May 31, 2018

The sign shall be posted adjacent to work area. All costs involved shall be considered as included in the prices paid for mobilization items of work and no additional payment will be made therefor.

Any construction area traffic control signs will be installed prior to start of construction and maintained in place for the duration of the project by Contractor. Signs shall be repaired or replaced at no cost, if damaged or stolen. Contractor shall remove the signs and posts at the completion of the project and with

prior approval of Engineer.

Mobilization shall conform to the provisions of Sections 9-3.4 of the Standard Specifications.

MEASUREMENT AND PAYMENT

MOBILIZATION will be measured lump sum, as determined by adherence to all items shown on the Plans, details in these Special Provisions, and direction from the City of Agoura Hills and the Engineer.

Payment for mobilization will be made at the lump sum contract price bid for MOBILIZATION, as set forth on the BID SCHEDULE. The contract price shall include full compensation for furnishing all labor, materials, tools, equipment, and incidentals, and for doing all work involved in installing, maintaining, removing and disposing of the temporary barriers, erosion control features, signs, as well as constructing any necessary access road, and for avoidance of sensitive species, as shown on the Plans, as specified herein and in the Standard Specifications, as required by the permits, and as directed by the Engineer.

2. CONSTRUCTION SURVEYING AND STAKEOUT

GENERAL

Contractor shall be responsible for all construction surveying and layout. In accordance with Chapter 15, Article 3, and Section 8726 (a) and (b) of the Business and Professions Code, all engineering surveying shall be done under the direct supervision of a California Professional Land Surveyor (or a person registered to practice Land Surveying in the State of California).

The survey control information is as shown on the Plans, and is available from the Engineer.

The Contractor shall provide to the Engineer at the preconstruction meeting the name, address, phone number and the registration number of the Professional Land Surveyor who will be in responsible charge for construction staking and monument preservation. The Land Surveyor shall be responsible for the correct determination of all lines, grades, distances and elevations, and property easement lines.

All products and services provided by the Contractor's surveyor shall be done in conformance with the Professional Land Surveyors Act, Sections 8700 to 8805, Business and Professions Code, State of California.

Contractor shall be responsible for layout of all improvements. The City may make minor adjustments to alignment to suit actual field conditions at no extra cost.

The Contractor's surveyor shall coordinate with the City Surveyor regarding such items as survey control, monuments, benchmarks, presentation products and other matters related or pertaining to survey issues.

The Contractor's surveyor shall certify by signature and seal all survey documents (cut sheets, staking diagrams, subgrade certifications, concrete form certifications, and field notes) and deliver five (5) copies to the City two (2) working days prior to commencement of any particular construction work. The City will review survey documents for acceptable format and will provide the Contractor with three (3) copies of survey documents.

The Contractor's surveyor shall re-establish all existing control points damaged or removed during construction outside the work area including filing of any required corner record maps with the County of Los Angeles at no additional cost to City.

The City reserves the right to perform quality control surveys to ensure conformance with contract Special Provisions as deemed necessary or appropriate by the City Surveyor or City Inspector. Contractor shall render whatever assistance necessary to allow access by City Survey Crew at no additional cost to City.

The Plans as needed for layout shall be provided in an electronic format (AutoCAD version 2010 as a courtesy to the layout surveyor. The City will not be responsible for any modifications to the electronic files by others or for any errors or omissions found within the files. The delivery of the electronic files does not constitute the official contract Plans or drawings. In the event of any questions or discrepancies between the electronic Plans files and the approved Plans, the paper Plans will prevail.

The Contractor shall be responsible for protecting and perpetuating existing and any new permanent survey monuments affected by construction activities in accordance with Business and Professions Code Section 8771. The Contractor shall be responsible for referring, resetting, and filing of corner records for all survey monuments disturbed or destroyed by construction activities in accordance with Business and Professions Code Section 8771.

Contractor is also responsible for performing quality control survey at the direction of the Engineer, and providing written and electronic records of measurements upon request by the City or Engineer.

MATERIALS

Not used.

EXECUTION

Not used.

MEASUREMENT AND PAYMENT

Construction Surveying and Stakeout will be measured lump sum, as determined by adherence to all items shown on the Plans, details in these Special Provisions, and direction from the City of Agoura Hills and the Engineer.

Payment for Construction Surveying and Stakeout will be made at the lump sum contract price bid for SURVEY AND STAKEOUT, as set forth on the BID SCHEDULE. The contract price shall include full compensation for furnishing all labor, materials, tools, equipment, and incidentals, and for doing all work involved in performing construction surveys, complete in place, including protecting and re-establishing existing control points within project limits, as shown on the Plans, as specified herein and in the Standard Specifications, as required by the permits, and as directed by the Engineer.

3 & 6. CONSTRUCT CONCRETE ADA RAMPS& DRIVEWAY APPROACHES.

This work shall consist of removal of all cuttings, tree roots, base and spoil material, and removed concrete, excavation, preparation of sub-grade, placement of fill, compaction of sub-base and aggregate base, construction of 5" thick concrete sidewalk, ADA curb ramps, driveway approaches, drill and

construct piles & cap foundation, and asphalt concrete (AC) pavement repair. All work shall conform to Sections 300-1, 301-1, 302-6 and 303-5 of the SSPWC, except as amended or modified herein.

Note: This project includes removal of sections of the existing equestrian trail & fencing as required for the construction of the accessibility path.

MATERIAL REQUIREMENTS

A. Portland Cement Concrete

All Portland Cement Concrete (PCC) shall conform to Section 201-1 of the SSPWC, except as amended or modified by these special provisions and standard plans or drawings.

PCC shall be Transit-Ready-Mixed conforming to the appropriate ASTM Designation.

Concrete mixers and other equipment determined by the Engineer not to be adequate or suitable for the work shall be removed and suitable equipment provided by the Contractor at his own expense.

The allowance of slump shall not be more than four inches (4"). The amount of slump shall be twelve inches (12") minus the height after subsidence.

Test Specimens may be taken by the Engineer at any time deemed advisable from the transportation unit at the point of discharge and tested in conformance with the Standard Method of test for Compressive Strength of Molded Concrete cylinders, pursuant to the appropriate ASTM Designation.

B. Reinforcement for Concrete

All Reinforcing Steel Bars or any reinforcement for concrete specified shall conform to Section 201-2 of the SSPWC, except as amended or modified herein.

Reinforcing Steel Bars (rebar) shall be size No. 4, unless otherwise specified on the standard plans or drawings.

C. Expansion Joint Filler

All expansion joint filler used for treating joints in PCC shall conform to Section 201-3 of the SSPWC, except as amended or modified herein.

Expansion joint filler shall be pre-molded strips, one-half inch (1/2") thick, be shaped to fit the geometry of the curbs, gutters and/or sidewalks and extend for the full depth of the curbs, gutters and/or sidewalks.

D. Asphalt Concrete (AC)

AC pavement shall be Type B PG 64-10 and shall comply with Sections 203-6 and 302-5 of the SSPWC, except as amended or modified herein.

E. Paving Asphalt

Paving Asphalt (also referred to as tack coat) shall conform to Section 203-1 of the SSPWC.

F. ADA Curb Ramps

All curb ramps shall be constructed per SSPWC Std. Plan No. 114-1 per Federal ADA accessibility

guidelines (ADAAG).

The Contractor shall layout each ADA ramp a minimum of 5 working days prior to concrete placement. The layout will be in the presence of the City's representative. The layout will entail utilizing a "Smart-Tool" slope meter or equivalent, a 10-foot straight-edge, and, a carpenter's tape to ascertain that the ADA curb ramp designated for construction will meet all ADA requirements. Layout lines and limits shall be marked on the concrete with appropriate indelible markings at the curb ramp location for the layout of the ramp for saw-cuts and removals.

G. Truncated Domes

General Requirements: This specification states the requirements for wet cast detectable warning panels for installation in curb ramps and hazardous areas.

Sample and Certified Test Reports: A representative sample of the proposed panel to be furnished must be submitted along with the required certified test reports for approval.

Standards: Detectable warning surface panels must comply with detectable warnings on walking surfaces section of the American with Disabilities Act (Title 49 CFR TRANSPORTATION, part 37.9 STANDARDS FOR ACCESSIBLE TRANSPORTATION FACILITIES, Appendix A, Section 4.29.2 DETECTABLE WARNINGS ON WALKING SURFACES.

Materials Requirements: Polymer concrete cast-in-place Detectable Warning Panels shall be manufactured using polymer concrete material. Polymer concrete material shall consist of calcareous and siliceous stone, glass fibers and thermo set polyester resin. The polymer concrete material shall be tested by an independent testing laboratory for chemical resistance and mechanical properties.

Chemical Resistance:

Chemical Resistance	ASTM D-543
Simulated Sunlight	ASTM D-1501
Accelerated Service Test	ASTM D-756 Procedure "E"
Water Absorption	ASTM D-570

Material shall be determined to be acceptable if the following criteria are met. For chemical resistance, simulated sunlight, accelerated service test, and water absorption: retention of 75 percent of the control specimen values for load and deflection and no more than 2 percent change in weight. For flammability test, specimen should be self-extinguishing. For fungus resistance test the material should not allow any fungus growth. Smoke density shall be less than 0.5 at 1.5 minutes and less than 15 at 4 minutes. Surface flammability shall be less than 25.

Mechanical Properties: The mechanical properties of polymer concrete material shall be tested by an independent testing laboratory. Polymer concrete material shall have the following mechanical properties:

<u>Mechanical Properties</u>	<u>Average Value</u>	<u>Test Method</u>
Compressive Strength	11,430 PSI	ASTM C-170-99
Flexural Strength	3,330 PSI	ASTM C-580-02
Tensile Strength	1,710 PSI	ASTM C307-99
Shear Strength	11,670 PSI	ASTM D-372-02
Modulus of Elasticity	1,776,400 PSI	ASTM C-580

1. For consistency, detectable warning panels shall be manufactured using matched die molds under heat and pressure for superior material compaction, controlled chemical curing and uniform dimensions.
2. Polymer concrete detectable warning panels shall be reinforced with fiberglass mats for superior strength.
3. Polymer concrete detectable warning panels shall have ½" thick material sectional thickness excluding truncated domes height or reinforcement ribs.
4. Polymer concrete detectable warning panels shall be fitted with Zinc alloy concrete anchors and stainless steel bolts.
5. Polymer concrete panel surface shall be coated to keep the panel surface clean during installation. The coating shall be easily removable immediately after installation.
6. Polymer concrete detectable warning panels shall be fitted with hot dipped galvanized angles to facilitate installation in wet concrete.
7. Polymer concrete detectable warning panels shall be field replaceable without the need of cutting the existing concrete or pouring new concrete.
8. Slip Resistance of Polymer concrete detectable warning panel when tested by ASTM-C 1028 shall not to be less than 0.80.
9. Chemical Resistance of Tile when tested by ASTM-D 543 to withstand without any degradation or discoloration-1% hydrochloric acid, Acetic Acid, Sulfuric Acid, Sodium Chloride Sodium Hydroxide, Sodium Sulfate, Sodium Carbonate, Kerosene and Oil.
10. The material shall be abrasive resistant and shall be warranted for 5 years against excessive wear.
11. The polymer concrete material shall not sustain burning and be self extinguishing when tested in accordance with ASTM D 635.
12. The polymer concrete material shall not promote fungus growth when tested in accordance with ASTM G21.
13. The polymer concrete material surface flammability shall be tested in accordance with ASTM E-162 and shall be less than 25.
14. Smoke density shall be tested in accordance with ASTM E-662-03 and shall be less than 0.5 at 1.5 minutes and less than 15 at 4 minutes.

Testing and Documentation Requirements:

The Polymer concrete Cast-In-Place Detectable Warning Panels specified is based on Armorcast Products Company (818-982-3600) or approved equal.

Certified test report must be submitted to demonstrate conformance to these specifications. Testing must be conducted by an independent testing laboratory.

Installation procedures must be submitted along with product drawings.

Installation:

1. The concrete mix shall conform to all requirements as specified by the contract document.
2. The tools required for installation are typical of those used by concrete finishers.
3. Do not remove the galvanized steel angle, inserts or bolts before placement. The panel shall be placed in concrete with all the hardware attached.
4. Follow all safety requirements that include but not limited to, State, Federal Industry safety standards.
5. After the concrete is poured, the contractor shall establish finished grade using mason line or other appropriate methods. The polymer concrete panel shall be placed on top of the concrete and tamped in place using installer's weight or concrete vibrator to facilitate placement in a low slump concrete. Final panel elevation shall be verified.

6. Make sure that you have the proper slope as specified in the contract document.
7. Low slump concrete may require 25 to 50 pounds weights to weigh down panels after placement in concrete.
8. Steel edging trowel with a minimum of 1/8" radius shall be used to edge the finished concrete around the panel.
9. Once concrete is hardened, remove weights and panel protective cover.

Finishing

All sidewalk areas shall be finished per details as shown on the plans. The Contractor shall be responsible to oversee the curing of all concrete improvements to prevent graffiti damage or other unauthorized markings in new concrete surfaces. Any concrete surface deemed unacceptable to the Engineer, shall be replaced by the Contractor at no cost to the City.

Admixtures

Should the Contractor request and obtain permission to use admixtures for his own benefit, he shall furnish such admixtures and incorporate them in the concrete mixture at his expense, and no additional compensation will be allowed therefore. All admixtures are required to be approved prior to use. The Contractor shall submit the product information for approval.

CONSTRUCTION METHODS

Miscellaneous Removals and Improvements

Removals shall be done in accordance with the provisions of Section 300-1 of the SSPWC, as modified in these Special Provisions and as shown on the Project Plans. Work under this section shall consist of performing all work involved with, but not limited to:

Removal of tree roots, base material, spoil material, saw cut and removed concrete, AC pavement to an approved disposal site. The areas of tree removals, concrete walks, curb and gutter, ramps and cross gutters will be designated by the Engineer prior to beginning of construction.

The Contractor shall remove and replace only those improvements within the designated removal sections. Any areas removed by the Contractor not approved by the City shall be at the Contractor's expense.

A. Tree Root Repair

Tree root repair consist of saw cutting, removing and disposing of tree roots, base materials and unclassified excavation, backfilling and compacting. Tree roots shall be saw cut and removed as directed by the City Landscape Architect. All tree root repair shall be supervised by the City Landscape Architect. Contractor shall notify the City Landscape Architect 48 hours in advance of commencing tree root repair and coordinate observation accordingly.

For locations where tree and stump are to be removed as directed by the Engineer, work shall include backfilling and compacting area of stump removal. Work associated with removal of tree and stump grinding shall be coordinated with City Landscape Contractor. The void created during stump grinding process shall be back-filled by the Contractor the same day the stump is removed, and if left unattended prior to backfilling, barricades/road cones shall be placed around the hole, in a manner that provides adequate warning to the general public. All damaged lawn and turf shall be repaired to the satisfaction of the Engineer.

All the root pruning required to place or replace walks, curbs, gutters, or other permanent facilities shall be limited to the minimum amount necessary to set forms.

All roots 2-inches and larger shall be cut with sharp tool such as an axe or chainsaw. No roots shall be broken off by trenching or other heavy equipment.

No root shall be removed within five (5) diameters of the tree trunk measured at 1.5m (4 feet, 9 inches) above grade without the express written permission of the City. Any such root removed without the City's written permission may create a hazardous condition for which the Contractor shall be liable.

No work shall be done within the protected zone of any oak tree without the express written permission of the City. Contractor shall adhere to all requirements as determined by the City. An Oak Tree Permit is required for any work approved in the protected zone of any oak tree.

Should the Contractor create a hazardous condition in the sole judgment of the Engineer, the Contractor shall remove the tree and replace it with a specimen of the same species and value at the Contractor's expense.

All significant root pruning (3-inch diameter and larger) shall be performed under the direct supervision of an ISA Certified Arborist in the Contractor's employ.

B. Asphalt Concrete Removal

Pavement removal shall consist of saw cutting, removing and disposing of asphalt concrete pavement, PCC pavement, base materials and unclassified excavation.

All asphalt concrete pavement and PCC pavement to be removed shall be saw cut to a true line where new pavement is to join existing pavement. Saw cuts shall be to a minimum depth of 2 inches. Pavement removal operations shall be performed without damage to any portion which is to remain in place. All damage to the existing pavement, which is to remain in place, shall be repaired to a condition equal to which existed prior to the beginning of removal operations.

C. Concrete Removal

Concrete removal shall consist of saw cutting, removing and disposing of concrete sidewalks, curb and gutters, ramps, cross gutters.

All concrete to be removed shall be saw cut with a minimum depth of 1 inch to a true line along the nearest score mark or joint. Concrete sidewalk, access ramp, or driveway to be removed shall be neatly sawed in straight lines either parallel to the curb or at right angles to the alignment of the sidewalk. Curb and gutter shall be sawed to a depth of 1 inch on a neat line at right angles to the curb face. Concrete removal operations shall be performed without damage to any portion which is to remain in place. All damage to the existing structures, which is to remain in place, shall be repaired to a condition equal to which existed prior to the beginning of removal operations.

D. Unclassified Fill

Use of unclassified fill shall conform to Section 300-4 of the SSPWC. Unclassified fill shall consist of approved base material to be placed along the edge of pavement at areas determined by the Engineer. Fill areas shall be prepared in accordance with Section 300-4.2. Placement of fill material shall be done

in accordance with Section 300-4.5.

E. Sub-grade Preparation

Sub-grade preparation prior to placement of pavement, curbs and gutters, sidewalks, driveways, cross gutters or other roadway structures shall conform to Section 301-1 of the SSPWC, unless otherwise modified or amended herein.

The following language is added to Subsection 301-1.2 of the SSPWC: The Contractor shall scarify and cultivate the exposed surface to a depth of six (6) inches, moisture conditioned to optimum moisture content of approximately 22 percent and mechanically compacted to at least 90 percent of the maximum density of soil.

The first paragraph of Subsection 301-1.3 of the SSPWC is hereby deleted and replaced with the following: When pavement is to be placed directly on sub-grade material or when base or sub-base material, curb, gutter, driveways, or sidewalks are to be placed on the sub-grade material, the top six (6) inches of such sub-grade material shall be compacted to a relative compaction of 90 percent.

F. Driveway Approaches, and ADA Curb Ramps

All work shall conform to Section 303-5 of the SSPWC, except as amended or modified herein and by City standard plans or drawings.

To replace cracked, broken, heaved or otherwise unacceptable concrete, the entire curb and gutter and/or sidewalk shall be removed and reconstructed, as directed by the Engineer.

Adjacent to all areas of AC removed, a one-foot (1') minimum width, two-inch (2") minimum depth of existing roadway pavement shall be saw cut and removed and replaced with AC pavement.

G. Expansion Joint, Weakened Plane Joint & Score Line

Work under this section shall conform to Section 303-5.4.2 and 303-5.4.3 of the SSPWC, except as amended or modified herein and by City Standard Plan 107.

H. Curb and Gutter

Work under this section shall conform to Section 303-5.5.2 and 303-5.5.4 of the SSPWC, except as amended or modified herein and by City Standard Plan 105.

I. Sidewalk

Work under this section shall conform to Section 303-5.5.3 of the SSPWC, except as amended or modified herein. Areas that required removal of tree, shall be formed to include a new 3 feet by 4 feet tree well or as directed by Engineer.

J. ADA Access (Curb) Ramps and Driveways

Work under this section shall conform to Section 303-5.5.5 of the SSPWC, except as amended or modified herein and by City Standard Plans 109, or as direct by the Engineer.

Curb ramps and driveways shall be constructed to the details shown or specified in the Contract,

Standard Plans for Public Works Construction, City Standard Plans and as directed by the Engineer.

Construction limits for access ramps shall extend from BCR to ECR. No utility pull box, utility pole, traffic signal pull box, traffic signal pole foundation or any other facility that is visible on or above the surface of a curb ramp may be located within the area of a curb ramp.

For the purpose of these Special Provisions, the area of the curb ramp shall be the area including and bounded by the one-foot (1') wide tactile strip on either side of the included portion of the ramp, the gutter section and the curb along the back of the sidewalk. The limit may be extended up to the nearest score mark per the Engineer's direction.

Dual ramps are considered as one curb-ramp and paid as one unit of bid price item.

Contractor shall be responsible for installing curb ramp such that runoff does not accumulate at the flow line.

The Contractor shall install wet set yellow truncated dome panels as the detectable warning surface. The detectable warning surface must extend a minimum of 3 feet in the direction of travel and for the full width of the curb ramp.

MEASUREMENT AND PAYMENT

Measurement and payment for construction driveway approaches shall be per each unit bid price, measurement and payment for construction of ADA access (curb) ramps shall be each unit bid price, and includes the installation of truncated domes anywhere shown on the plans including at the north side of Driver Ave.

Payment for each item shall be payable after the task is performed completely.

The above contract prices shall include full compensation for all labor, equipment, materials, tools and all incidentals required to complete the job as outlined in these Specifications and as directed by the Engineer.

4 & 5 DECOPMPOSED GRINITE SURFACING (STABILIZED)

GENERAL

The General Conditions and the Supplementary Conditions shall apply to all of the work of every Division, Section, or Subsection of these Special Provisions as if fully repeated in each.

Contractor shall provide all material, labor and equipment necessary to complete all work as shown on the drawings and as specified herein, including, but not limited to, the following:

Installation of decomposed granite for public access features.

Submittals: In addition to requested substitutions, provide submittals for the following items:

Decomposed Granite: Contractor shall submit a one gallon container of the proposed decomposed granite mixture to the District, prior to purchase or delivery, for approval of the color mix.

MATERIALS

Decomposed granite (DG) shall be grey or brown. Material shall be crushed granite rock screenings graded from 3/8-inch particles and comply with the following gradation:

Grading Requirements

Sieve Size	Percent Passing
3/8-inch	100
No. 4	95-100
No. 8	75-80
No. 16	55-65
No. 30	40-50
No. 50	25-35
No. 100	20-25
No.200	5-15

Gradation based on AASHTO
T11-82 and T27-82

EXECUTION

Prior to delivery of the decomposed granite, the subgrade shall be shaped and compacted to conform to the typical sections and limits of grading shown in the design plan or as directed by the Engineer.

DG shall not be installed during rainy conditions.

Place DG uniformly in layers no more than 2 inches thick and compacted to a minimum of 90% relative compaction.

When work is complete, the surface must be smooth, uniform, and maintain original flow lines, slope gradient, and contours as shown on the Plans.

MEASUREMENT

Decomposed Granite Surfacing and Path will be measured by square foot , and this work includes the underlying Aggregate Base (AB), ramped approaches at the bridge entrances, and keystone gravity walls at east and west side of the bridge, complete in place, as determined by adherence to all items shown on the Plans, details in these Special Provisions, and direction from the City of Agoura Hills and the Engineer.

PAYMENT

Payment for Decomposed Granite Surfacing & Path will be made at the square foot unit contract price bid for Decomposed Granite Surfacing & Path, as set forth on the BID SCHEDULE. The contract price shall include full compensation for furnishing all labor, materials, tools, equipment, and incidentals, and for doing all work involved, as shown on the Plans, as specified herein and in the Standard Specifications, as required by the permits, and as directed by the Engineer.

7. CONCRETE STRUCTURES GENERAL

SUMMARY OF WORK

This item includes furnishing and installing Portland cement concrete structures, including bridge piles and abutments, and shall be complied with as specified in the Standard Specifications, the Plans, and these Special Provisions.

Shotcrete shall not be used as an alternative construction method for reinforced concrete members unless otherwise specified.

Reinforcement shall conform to the provisions in Section 52, "Reinforcement," of the State Standard Specifications.

MATERIALS

Portland cement concrete shall conform to the provisions in Section 90, "Portland Cement Concrete," of the Standard Specifications and these Special Provisions.

References to Section 90 2.01, "Portland Cement," of the Standard Specifications shall mean Section 90 2.01, "Cement," of the Standard Specifications.

Mineral admixture shall be combined with cement in conformance with the provisions in Section 90 4.08, "Required Use of Mineral Admixtures," of the Standard Specifications for the concrete materials specified in Section 56 2, "Roadside Signs," of the Standard Specifications.

The requirements of Section 90 4.08, "Required Use of Mineral Admixture," of the Standard Specifications shall not apply to Section 19 3.025C, "Soil Cement Bedding," of the Standard Specifications.

EXECUTION

The Department maintains a list of sources of fine and coarse aggregate that have been approved for use with a reduced amount of mineral admixture in the total amount of cementitious material to be used. A source of aggregate will be considered for addition to the approved list if the producer of the aggregate submits to the Transportation Laboratory certified test results from a qualified testing laboratory that verify the aggregate complies with the requirements. Prior to starting the testing, the aggregate test shall be registered with the Department. A registration number can be obtained by calling (916) 227 7228. The registration number shall be used as the identification for the aggregate sample in correspondence with the Department. Upon request, a split of the tested sample shall be provided to the Department. Approval of aggregate will depend upon compliance with the

specifications, based on the certified test results submitted, together with any replicate testing the Department may elect to perform. Approval will expire 3 years from the date the most recent registered and evaluated sample was collected from the aggregate source.

Qualified testing laboratories shall conform to the following requirements:

- a. Laboratories performing ASTM Designation: C 1293 shall participate in the Cement and Concrete Reference Laboratory (CCRL) Concrete Proficiency Sample Program and shall have received a score of 3 or better on all tests of the previous 2 sets of concrete samples.
- b. Laboratories performing ASTM Designation: C 1260 shall participate in the Cement and Concrete Reference Laboratory (CCRL) Pozzolan Proficiency Sample Program and shall have received a score of 3 or better on the shrinkage and soundness tests of the previous 2 sets of pozzolan samples.

Aggregates on the list shall conform to one of the following requirements:

- a. When the aggregate is tested in conformance with the requirements in California Test 554 and ASTM Designation: C 1293, the average expansion at one year shall be less than or equal to 0.040 percent; or
- b. When the aggregate is tested in conformance with the requirements in California Test 554 and ASTM Designation: C 1260, the average of the expansion at 16 days shall be less than or equal to 0.15 percent.

The amounts of cement and mineral admixture used in cementitious material shall be sufficient to satisfy the minimum cementitious material content requirements specified in Section 90 1.01, "Description," or Section 90 4.05, "Optional Use of Chemical Admixtures," of the Standard Specifications and shall conform to the following:

- a. The minimum amount of cement shall not be less than 75 percent by weight of the specified minimum cementitious material content.
- b. The minimum amount of mineral admixture to be combined with cement shall be determined using one of the following criteria:
 - (1) When the calcium oxide content of a mineral admixture is equal to or less than 2 percent by weight, the amount of mineral admixture shall not be less than 15 percent by weight of the total amount of cementitious material to be used in the mix.
 - (2) When the calcium oxide content of a mineral admixture is greater than 2 percent by weight, and any of the aggregates used are not listed on the approved list as specified in these Special Provisions, then the amount of mineral admixture shall not be less than 25 percent by weight of the total amount of cementitious material to be used in the mix.
 - (3) When the calcium oxide content of a mineral admixture is greater than 2 percent by weight and the fine and coarse aggregates are listed on the approved list as specified in these Special Provisions, then the amount of mineral admixture shall not be less than 15 percent by weight of the total amount of cementitious material to be used in the mix.
 - (4) When a mineral admixture that conforms to the provisions for silica fume in Section 90 2.04, "Admixture Materials," of the Standard Specifications is used, the amount of mineral admixture shall not be less than 10 percent by weight of the total amount of cementitious material to be used in the mix.
 - (5) When a mineral admixture that conforms to the provisions for silica fume in Section 90 2.04, "Admixture Materials," of the Standard Specifications is used and the fine and

coarse aggregates are listed on the approved list as specified in these Special Provisions, then the amount of mineral admixture shall not be less than 7 percent by weight of the total amount of cementitious material to be used in the mix.

- c. The total amount of mineral admixture shall not exceed 35 percent by weight of the total amount of cementitious material to be used in the mix. Where Section 90 1.01, "Description," of the Standard Specifications specifies a maximum cementitious content in pounds per cubic yard, the total weight of cement and mineral admixture per cubic yard shall not exceed the specified maximum cementitious material content.

MEASUREMENT AND PAYMENT

Concrete Structures will be measured lump sum, as determined by adherence to all items shown on the Plans, details in these Special Provisions, and direction from the City of Agoura Hills and the Engineer.

Payment for Concrete Structures will be made at the lump sum contract price bid for CONCRETE BRIDGE PILES WITH STEEL SLEVE, STEEL REINFORCEMENT & ABUTMENTS, as set forth on the BID SCHEDULE. The contract price shall include full compensation for furnishing all labor, materials, tools, equipment, and incidentals, and for doing all work involved, as shown on the Plans, as specified herein and in the Standard Specifications, as required by the permits, and as directed by the Engineer.

8. UNLOAD & INSTALL BRIDGE & DECK

The Contractor shall provide all material, to construct pile foundation & abutments, equipment to unload per bridge manufacturer's instructions and erect as indicated on the Plans the prefabricated steel bridge spans in accordance with these Special Provisions and the contract Plans. One fully engineered clear span steel bridge shall be installed as shown on the Plans.

The bridge has been ordered by the City of Agoura Hills and is *a pre-fabricated approximately 64 feet long by 10 feet wide steel pedestrian bridge by Excel Bridge Manufacturing Company.*

Abutment Seat Elevation:

Top of abutment concrete seat elevations shown are approximate and shall be adjusted as necessary to provide for end of bridge connection details so that required deck surface profile is provided.

EXECUTION

Delivery and Erection

The Contractor shall be responsible for the unloading and erection of the bridge superstructure. The Contractor shall provide necessary temporary access and ground preparation as required within the limits of work shown on the Plans for delivery of the bridge superstructure to the location of erection. Trucks and trailers heavier than 3 Tons shall not use any areas after placement of decomposed granite or asphalt surfacing.

The manufacturer will provide detailed, written instruction in the proper lifting procedures and splicing procedures (if required). The Contractor shall submit a Certificate of Compliance in accordance with Section 6-1.07 of the Standard Specifications indicating that all of the bridge manufacturer's lifting and splicing procedures have been adhered to during the bridge span erection process.

Bearing Devices

The bridge bearings at abutments shall sit on the concrete abutment as shown on the Plans. The step height (from bottom of bearing to top-of-deck) shall be determined by the bridge manufacturer and the abutment concrete bearing seat elevation and back wall parapet height shall be adjusted as required to provide the deck plan profile grade as shown on the Plans.

Steel reinforced elastomeric bearing pads, conforming to the provisions in Section 51-1.12H, "Elastomeric Bearing Pads," of the State Standard Specifications, shall be placed at abutments as shown on the Plans. Bearing pads shall be designed for a maximum service level bearing stress of 1000 psi and a minimum bearing stress under dead load only of 200 psi. Bearing pad thickness shall have a 1" minimum total (thickness of elastomer only).

Bearing Supports

Anchor bolts and sole plates shall be designed to restrain transverse seismic forces at ultimate strength capacity and prevent uplift at supports due to overturning loads. The anchor bolts shall not restrain the bridge in the longitudinal direction for the full anticipated thermal movement as defined herein. Elevations of tops abutments shall be revised as needed to provide deck surface profile grade as shown on the Plans. Working drawings of the prefabricated truss shall indicate distance from bridge walkway surface to bottom of bearing plates at each support.

MEASUREMENT & PAYMENT

Measurement for Unload & Install of the Bridge and Deck shall be measured lump sum, as determined by adherence to all items shown on the Plans, details in these Special Provisions, and direction from the City of Agoura Hills and the Engineer.

PAYMENT Payment for Unloading & Installing the Bridge and Deck shall be lump sum and shall include all equipment and labor needed to unload & install the bridge per manufacturer's instructions.

9. EXISTING STRIPING REMOVAL & RE-STRIPING OF NEW CROSS WALK

GENERAL

This work shall consist of removal, relocation and/or installation of striping, pavement markings, limit lines, and reflective and non-reflective markers per plan and in accordance with the California Manual On Uniform Traffic Control Devices (CAMUTCD), State Standard Plans and State Standard Specifications.

Except as provided below or as otherwise directed, Contractor shall replace traffic striping, pavement markings, signs and curb markings removed or damaged by the work in-kind and as shown on the

Plans. It shall be the responsibility of the Contractor to document existing striping and pavement markings.

Raised pavement markers that are damaged or missing shall be replaced by the Contractor.

REMOVAL OF EXISTING STRIPING, MARKINGS, AND MARKERS

All striping and pavement markings not intended to be replaced in kind in exactly the same place shall be removed.

STRIPING LAYOUT

Striping layout shall be approved by the Engineer before placing pavement markers and permanent striping.

PAINT

Where painting is allowed as specified on the Plans, painting of pavement markings and striping shall be in accordance with Section 84-1 "General" and 84-3 "Painted Traffic Stripes and Pavement Markings" of SSS, except that all traffic markings and striping constructed with Rapid Dry Paint shall be made in two (2) applications, three (3) days minimum between each application. The first coat thickness shall be as specified for the first of two coats in SSS Section 84-3; the second coat thickness shall be as specified for a single coat application. The first application shall be applied within 48 hours after slurry or AC paving and the final application shall be applied after two calendar days but no later than ten calendar days after slurry or AC paving. **To prevent motorists from driving through and tracking wet paint, traffic control shall be installed and maintained until the paint is completely dry.**

Where the work entails replacement of a portion of a crosswalk, limit line, legend, or other markings, the entire marking (i.e. entire crosswalk) shall be replaced/repainted.

RAISED REFLECTIVE AND NON-REFLECTIVE PAVEMENT MARKERS

Raised reflective and non-reflective pavement markers shall meet the requirements of Section 85 of the State Standard Specifications and shall be installed within ten days after asphalt concrete construction. Non-reflective markers shall conform to Section 851.04B "Non-Reflective Pavement Markers (Plastic)" of the State Standard Specifications. In addition to other requirements, a blue 2-way reflective raised pavement marker shall be placed four inches from the street centerline or lane line at each fire hydrant.

MEASUREMENT AND PAYMENT

Measurement and Payment for Striping, Pavement Markings, and Markers shall be at the lump sum price bid and shall include, but not limited to, full compensation for furnishing all labor, materials, tools, equipment, transportation, and incidentals for doing all work including, but not limited to, removing existing striping, constructing new traffic striping, pavement markings, and raised pavement markers, complete, and in place, as shown on the plans, and no additional compensation will be allowed therefor.

707 STORMWATER POLLUTION PREVENTION PLAN

707-1 SCOPE OF WORK

The work under this section covers full compliance of National Pollution Discharge Elimination System (NPDES) and implementing Storm Water Pollution Prevention Plan (SWPPP) during the construction period of this project. The work covered in this section covers all labor, materials, tool, equipment and incidentals necessary to provide full compliance with the stated objectives.

The Contractor shall monitor General Site Management, Construction Material Management and install and maintain temporary erosion and sediment control devices to prevent storm water pollution draining into natural streams and existing storm drain systems.

The nature of the work is such that the Contractor does not have to file a Notice of Intent and SWPPP with the State Regulatory Agency. However, Contractor will be required to meet the minimum BMP's as outlined in the "Development Construction Model Program for Storm Water Management within the County of Los Angeles." Thus, Contractor to submit a local SWPPP and a wet weather erosion control plan during the rainy season (October 1 to April 15) to comply with City policy regarding storm water management. The Contractor shall take all necessary precautions to minimize storm water pollution and control the pollutants from entering the drainage system as directed by the City's Representative.

At any point during the project, a local SWPPP is subject to change if the City determines the inadequacy of the approved SWPPP to address the pollutants of concern. Upon written notification by the City, Contractor shall submit a revised SWPPP, subject to City approval, within 5 working days following notification. Failure to do so could result in a stoppage of all work.

707-2 MEASUREMENT AND PAYMENT

This is a general requirement of the Contract and no separate payment will be made for complying with the requirements outlined in this section. Full compensation for adhering to the project schedule shall be considered in the price bid for the various items of work, and no additional compensation will be allowed therefore.

CHECKLIST FOR EXECUTION OF CONSTRUCTION CONTRACT

TO BE SUBMITTED BY SUCCESSFUL BIDDER:

- _____ Two executed and notarized copies of the contract
- _____ Payment Bond in amount of the contract
- _____ Performance Bond in amount of the contract
- _____ Workers' Compensation Certificate
- _____ Liability insurance certificate in the amount of _____, naming the City as a co-insured
- _____ Automobile insurance certificate in the amount of _____, naming the City as a co-insured
- _____ General aggregate insurance certificate in the amount of _____, naming the City as a co-insured
- _____ Copy of City business license
- _____ Additional insured endorsement – comprehensive general liability
- _____ Additional insured endorsement – automobile liability
- _____ Additional insured endorsement – excess liability

CONTRACT

CITY OF AGOURA HILLS CONTRACT FOR

THIS CONTRACT ("Contract") is made and entered this _____ day of _____, 20__ ("Effective Date"), by and between the CITY OF AGOURA HILLS, a California municipal corporation ("City") and _____ ("Contractor"). Contractor's license number is _____.

In consideration of the mutual covenants hereinafter set forth, the parties hereto agree as follows:

1. Contract Documents. The Contract Documents consist of this Contract, the Notice Inviting Bids, Instructions to Bidders, Bid (including documentation accompanying the Bid and any post-Bid documentation submitted before the Notice of Award), the Bonds, permits from regulatory agencies with jurisdiction, General Provisions, Special Provisions, Plans, Standard Plans, Standard Specifications, Reference Specifications, Addenda, Change Orders, and Supplemental Agreements. The Contract Documents are attached hereto and incorporated herein by reference. In the event of any conflict between the terms of this Contract and any incorporated documents, the terms of this Contract shall control.

2. Scope of Services. Contractor shall perform the Work in a good and workmanlike manner for the project identified as _____ ("Project"), as described in this Contract and in the Contract Documents.

3. Compensation. In consideration of the services rendered hereunder, City shall pay Contractor a not to exceed amount of _____ dollars (\$_____) in accordance with the prices as submitted in Contractor's Proposal, attached hereto as Exhibit "B" and incorporated herein by this reference.

4. Incorporation by Reference. All of the following documents are attached hereto and incorporated herein by this reference: Workers' Compensation Certificate of Insurance; Additional Insured Endorsement (Comprehensive General Liability); Additional Insured Endorsement (Automobile Liability); and Additional Insured Endorsement (Excess Liability).

5. Antitrust Claims. In entering into this Contract, Contractor offers and agrees to assign to the City all rights, title, and interest in and to all causes of action it may have under Section 4 of the Clayton Act (15 U.S.C. Sec. 15) or under the Cartwright Act (Chapter 2 (commencing with Section 16700) of Part 2 of Division 7 of the California Business and Professions Code) arising from purchases of goods, services, or materials pursuant to the Contract. This assignment shall be made and become effective at the time the City tenders final payment to Contractor without further acknowledgment by the parties.

6. Prevailing Wages. City and Contractor acknowledge that this Project is a public work to which prevailing wages apply. The provisions of Section 7-2 of the General Provisions shall apply and are mandatory for this Project.

7. Workers' Compensation. California Labor Code Sections 1860 and 3700 provide that every contractor will be required to secure the payment of compensation to its employees. In accordance with the provisions of California Labor Code Section 1861, by signing this Contract, the Contractor certifies as follows:

"I am aware of the provisions of Section 3700 of the Labor Code which

require every employer to be insured against liability for workers' compensation or to under take self-insurance in accordance with the provisions of that code, and I will comply with such provisions before commencing the performance of the Work of this Contract."

8. Titles. The titles used in this Contract are for convenience only and shall in no way define, limit or describe the scope or intent of this Contract or any part of it.

9. Authority. Any person executing this Contract on behalf of Contractor warrants and represents that he or she has the authority to execute this Contract on behalf of Contractor and has the authority to bind Contractor to the performance of its obligations hereunder.

10. Entire Agreement. This Contract, including any other documents incorporated herein by specific reference, represents the entire and integrated agreement between City and Contractor. This Contract supersedes all prior oral or written negotiations, representations or agreements. This Contract may not be modified or amended, nor any provision or breach waived, except in a writing signed by both parties which expressly refers to this Contract.

11. Counterparts. This Contract may be executed in counterpart originals, duplicate originals, or both, each of which is deemed to be an original for all purposes.

IN WITNESS WHEREOF, the parties hereto have executed the Contract the day and year first above written.

CITY OF AGOURA HILLS

By: _____
Mayor

ATTEST:

APPROVED AS TO FORM:

By: _____
City Clerk

By: _____
City Attorney

Dated: _____

("CONTRACTOR")

By: _____

Printed Name: _____

Title: _____

By: _____

Printed Name: _____

Title: _____

**PAYMENT BOND
(LABOR AND MATERIALS)**

KNOW ALL PERSONS BY THESE PRESENTS that:

WHEREAS the City of Agoura Hills ("Public Agency"), State of California, has awarded to _____

("Principal")

(Name and address of Contractor)

a contract (the "Contract") for the Work described as follows:

(Project name)

WHEREAS, under the terms of the Contract, the Principal is required before entering upon the performance of the work, to file a good and sufficient payment bond with the Public Agency to secure the claims to which reference is made in Title 3 (commencing with Section 9000) of Part 6 of Division 4 of the Civil Code.

NOW, THEREFORE, we, the undersigned Principal, and _____

(Name and address of Surety)

("Surety") a duly admitted surety insurer under the laws of the State of California, as Surety, are held and firmly bound unto the Public Agency and all contractors, subcontractors, laborers, material suppliers, and other persons employed in the performance of the agreement and referred to in Title 3 (commencing with Section 9000) of Part 6 of Division 4 of the Civil Code in the penal sum of _____

Dollars (\$ _____), for materials furnished or labor thereon of any kind, or for amounts due under the Unemployment Insurance Act with respect to this work or labor, that the surety will pay the same in an amount not exceeding the amount hereinabove set forth, and also in case suit is brought upon this bond, will pay, in addition to the face amount thereof, costs and reasonable expenses and fees, including reasonable attorneys' fees, incurred by Public Agency in successfully enforcing this obligation, to be awarded and fixed by the court, and to be taxed as costs and to be included in the judgment therein rendered.

It is hereby expressly stipulated and agreed that this Bond shall inure to the benefit of any and all persons, companies, and corporations entitled to file claims under Title 3 (commencing with Section 9000) of Part 6 of Division 4 of the Civil Code, so as to give a right of action to them or their assigns in any suit brought upon this Bond.

Upon expiration of the time within which the California Labor Commissioner may serve a civil wage and penalty assessment against the principal, any of its subcontractors, or both the principal and its subcontractors pursuant to Labor Code Section 1741, and upon expiration of the time within which a joint labor management committee may commence an action against the principal, any of its subcontractors, or both the principal and its subcontractors pursuant to Labor Code Section 1771.2, if the condition of this bond be fully performed, then this obligation shall become null and void, otherwise it shall be and remain in full force and effect.

The Surety hereby stipulates and agrees that no change, extension of time, alteration, or addition to the terms of the Contract or the specifications accompanying the same shall in any manner affect its obligations on this Bond, and it does hereby waive notice of any such change, extension, alteration, or addition.

IN WITNESS WHEREOF, two (2) identical counterparts of this instrument, each of which shall for all purposes be deemed an original hereof, have been duly executed by Principal and Surety, on the date set forth below, the name of each corporate party being hereto affixed and these presents duly signed by its undersigned representative(s) pursuant to authority of its governing body.

Dated: _____

“Principal”

“Surety”

By: _____
Its

By: _____
Its

By: _____
Its

By: _____
Its

(Seal)

(Seal)

APPROVED AS TO FORM:

RICHARDS, WATSON & GERSON
A Professional Corporation

By: _____
Public Agency Attorney

Note: This Bond must be executed in duplicate and dated, all signatures must be notarized, and evidence of the authority of any person signing as attorney-in-fact must be attached. IF CONTRACTOR IS A PARTNERSHIP, ALL PARTNERS MUST EXECUTE BOND. DATE OF BOND MUST NOT BE PRIOR TO DATE OF CONTRACT. Surety companies executing Bonds must appear on the Treasury Department's most current list (Circular 570 as amended) and be authorized to transact business in the State where the project is located.

PERFORMANCE BOND

KNOW ALL PERSONS BY THESE PRESENTS that:

WHEREAS the City of Agoura Hills ("Public Agency"), has awarded to _____

(Name and address of Contractor) ("Principal")

a contract (the "Contract") for the Work described as follows:

(Project name)

WHEREAS, Principal is required under the terms of the Contract to furnish a Bond for the faithful performance of the Contract.

NOW, THEREFORE, we, the undersigned Principal, and _____

(Name and address of Surety)

("Surety") a duly admitted surety insurer under the laws of the State of California, as Surety, are held and firmly bound unto the Public Agency in the penal sum of _____

Dollars (\$ _____), this amount being not less than the total Contract Price, in lawful money of the United States of America, for the payment of which sum well and truly to be made, we bind ourselves, our heirs, successors executors and administrators, jointly and severally, firmly by these presents.

THE CONDITION OF THIS OBLIGATION IS SUCH THAT, if the hereby bounded Principal, his, her or its heirs, executors, administrators, successors or assigns, shall in all things stand to and abide by, and well and truly keep and perform the covenants, conditions and provisions in the Contract and any alteration thereof made as therein provided, on the Principal's part, to be kept and performed at the time and in the manner therein specified, and in all respects according to their true intent and meaning, and shall indemnify and save harmless the Public Agency, its officers, agents and employees, as therein stipulated, then this obligation shall become null and void; otherwise, it shall be and remain in full force and effect.

As a part of the obligation secured hereby and in addition to the face amount specified therefor, there shall be included costs and reasonable expenses and fees, including reasonable attorneys' fees, incurred by Public Agency in successfully enforcing such obligation, all to be taxed as costs and included in any judgment rendered.

The Surety hereby stipulates and agrees that no change, extension of time, alteration or addition to the terms of the Contract or of the Work to be performed thereunder or the specifications accompanying the same shall in anywise affect its obligations under this Bond, and it does hereby waive notice of any such change, extension of time, alteration or addition to the terms of the Contract or to the Work or to the specifications. Surety hereby waives the provisions of California Civil Code 2845 and 2849. The City is the principal beneficiary of this Bond and has all rights of a party hereto.

IN WITNESS WHEREOF, two (2) identical counterparts of this instrument, each of which shall for all purposes be deemed an original hereof, have been duly executed by Principal and Surety, on the date set forth below, the name of each corporate party being hereto affixed and these presents duly signed by its undersigned representative(s) pursuant to authority of its governing body.

Dated: _____

“Principal”

“Surety”

By: _____
 Its

By: _____
 Its

By: _____
 Its

By: _____
 Its

(Seal)

(Seal)

APPROVED AS TO FORM:

RICHARDS, WATSON & GERSHON
A Professional Corporation

By: _____
 Public Agency Attorney

Note: This Bond must be executed in duplicate and dated, all signatures must be notarized, and evidence of the authority of any person signing as attorney-in-fact must be attached. IF CONTRACTOR IS A PARTNERSHIP, ALL PARTNERS MUST EXECUTE BOND. DATE OF BOND MUST NOT BE PRIOR TO DATE OF CONTRACT. Surety companies executing Bonds must appear on the Treasury Department's most current list (Circular 570 as amended) and be authorized to transact business in the State where the project is located.

WORKERS' COMPENSATION CERTIFICATE OF INSURANCE

WHEREAS, the City of Agoura Hills ("City") has required certain insurance to be provided by:

NOW THEREFORE, the undersigned insurance company does hereby certify that it has issued the policy or policies described below to the following named insureds and that the same are in force at this time:

1. This certificate is issued to:

City of Agoura Hills
City Hall
30001 Ladyface Court
Agoura Hills, California 91301

2. The insureds under such policy or policies are:
-

3. Workers' Compensation Policy or Policies in a form approved by the Insurance Commissioner of California covering all operations of the named insureds as follows:

<u>Policy Number</u>	<u>Effective Date</u>	<u>Expiration Date</u>
_____	_____	_____
_____	_____	_____
_____	_____	_____

By: _____
Its Authorized Representative

ADDITIONAL INSURED ENDORSEMENT COMPREHENSIVE GENERAL LIABILITY

Name and address of named insured ("Named Insured"):

Name and address of Insurance Company ("Company"):

General description of agreement(s), permit(s), license(s), and/or activity(ies) insured:

Notwithstanding any inconsistent statement in the policy to which this endorsement is attached (the "Policy") or in any endorsement now or hereafter attached thereto, it is agreed as follows:

1. The City of Agoura Hills ("Public Agency"), its elected officials, officers, attorneys, agents, employees, and volunteers are additional insureds (the above named additional insureds are hereafter referred to as the "Additional Insureds") under the Policy in relation to those activities described generally above with regard to operations performed by or on behalf of the Named Insured. The Additional Insureds have no liability for the payment of any premiums or assessments under the Policy.

2. The insurance coverages afforded the Additional Insureds under the Policy shall be primary insurance, and no other insurance maintained by the Additional Insureds shall be called upon to contribute with the insurance coverages provided by the Policy.

3. Each insurance coverage under the Policy shall apply separately to each Additional Insured against whom claim is made or suit is brought except with respect to the limits of the Company's liability.

4. Nothing in this contract of insurance shall be construed to preclude coverage of a claim by one insured under the policy against another insured under the policy. All such claims shall be covered as third-party claims, i.e., in the same manner as if separate policies had been issued to each insured. Nothing contained in this provision shall operate to increase or replicate the Company's limits of liability as provided under the policy.

5. The insurance afforded by the Policy for contractual liability insurance (subject to the terms, conditions and exclusions applicable to such insurance) includes liability assumed by the Named Insured under the indemnification and/or hold harmless provision(s) contained in or executed in conjunction with the written agreement(s) or permit(s) designated above, between the Named Insured and the Additional Insureds.

6. The policy to which this endorsement is attached shall not be subject to cancellation, change in coverage, reduction of limits (except as the result of the payment of claims), or non-renewal except after written notice to Public Agency, by certified mail, return receipt requested, not less than thirty (30) Days before the effective date thereof. In the event of Company's failure to comply with this notice provision, the policy as initially drafted will continue in full force and effect until compliance with this notice requirement.

7. Company hereby waives all rights of subrogation and contribution against the Additional Insureds, while acting within the scope of their duties, from all claims, losses and liabilities arising out of or incident to the perils insured against in relation to those activities described generally above with regard to operations performed by or on behalf of the Named Insured regardless of any prior, concurrent, or subsequent active or passive negligence by the Additional Insureds.

8. It is hereby agreed that the laws of the State of California shall apply to and govern the validity, construction, interpretation, and enforcement of this contract of insurance.

9. This endorsement and all notices given hereunder shall be sent to Public Agency at:

City Manager
City of Agoura Hills
City Hall
30001 Ladyface Court
Agoura Hills, California 91301

706 Except as stated above and not in conflict with this endorsement, nothing contained herein shall be held to waive, alter or extend any of the limits, agreements, or exclusions of the policy to which this endorsement is attached.

<u>TYPE OF COVERAGES TO WHICH THIS ENDORSEMENT ATTACHES</u>	<u>POLICY PERIOD FROM/TO</u>	<u>LIMITS OF LIABILITY</u>
---	------------------------------	----------------------------

11. Scheduled items or locations are to be identified on an attached sheet. The following inclusions relate to the above coverages. Includes:

- | | |
|--|--|
| <input type="checkbox"/> Contractual Liability | <input type="checkbox"/> Explosion Hazard |
| <input type="checkbox"/> Owners/Landlords/Tenants | <input type="checkbox"/> Collapse Hazard |
| <input type="checkbox"/> Manufacturers/Contractors | <input type="checkbox"/> Underground Property Damage |
| <input type="checkbox"/> Products/Completed Operations | <input type="checkbox"/> Pollution Liability |
| <input type="checkbox"/> Broad Form Property Damage | <input type="checkbox"/> Liquor Liability |
| <input type="checkbox"/> Extended Bodily Injury | <input type="checkbox"/> _____ |
| <input type="checkbox"/> Broad Form Comprehensive | <input type="checkbox"/> _____ |
| General Liability Endorsement | <input type="checkbox"/> _____ |

12. A deductible or self-insured retention (*check one*) of \$ _____ applies to all coverage(s) except: _____ *if none, so state*). The deductible is applicable per claim or per occurrence (*check one*).

13. This is an occurrence or claims made policy (*check one*).

14. This endorsement is effective on _____ at 12:01 a.m. and forms a part of Policy Number _____.

I, _____ (*print name*), hereby declare under penalty of perjury under the laws of the State of California, that I have the authority to bind the Company to this endorsement and that by my execution hereof, I do so bind the Company.

Executed _____, 20____

Signature of Authorized Representative

(Original signature only; no facsimile signature or initialed signature accepted)

Telephone No.: (_____) _____

**ADDITIONAL INSURED ENDORSEMENT
AUTOMOBILE LIABILITY**

Name and address of named insured ("Named Insured"): _____

Name and address of Insurance Company ("Company"): _____

General description of agreement(s), permit(s), license(s), and/or activity(ies) insured:

Notwithstanding any inconsistent statement in the policy to which this endorsement is attached (the "Policy") or in any endorsement now or hereafter attached thereto, it is agreed as follows:

1. The City of Agoura Hills ("Public Agency"), its elected officials, officers, attorneys, agents, employees, and volunteers are additional insureds (the above named additional insureds are hereafter referred to as the "Additional Insureds") under the Policy in relation to those activities described generally above with regard to operations performed by or on behalf of the Named Insured. The Additional Insureds have no liability for the payment of any premiums or assessments under the Policy.

2. The insurance coverages afforded the Additional Insureds under the Policy shall be primary insurance, and no other insurance maintained by the Additional Insureds shall be called upon to contribute with the insurance coverages provided by the Policy.

3. Each insurance coverage under the Policy shall apply separately to each Additional Insured against whom claim is made or suit is brought except with respect to the limits of the Company's liability.

4. Nothing in this contract of insurance shall be construed to preclude coverage of a claim by one insured under the policy against another insured under the policy. All such claims shall be covered as third-party claims, i.e., in the same manner as if separate policies had been issued to each insured. Nothing contained in this provision shall operate to increase or replicate the Company's limits of liability as provided under the policy.

5. The insurance afforded by the Policy for contractual liability insurance (subject to the terms, conditions and exclusions applicable to such insurance) includes liability assumed by the Named Insured under the indemnification and/or hold harmless provision(s) contained or executed in conjunction with the written agreement(s) or permit(s) designated above, between the Named Insured and the Additional Insureds.

6. The policy to which this endorsement is attached shall not be subject to cancellation, change in coverage, reduction of limits (except as the result of the payment of claims), or non-renewal except after written notice to Public Agency, by certified mail, return receipt requested, not less than thirty (30) Days before the effective date thereto. In the event of Company's failure to comply with this notice provision, the policy as initially drafted will continue in full force and effect until compliance with this notice requirement.

7. Company hereby waives all rights of subrogation and contribution against the Additional Insureds, while acting within the scope of their duties, from all claims, losses and liabilities arising out of or incident to the perils insured against in relation to those activities described generally above with regard to operations performed by or on behalf of the Named Insured regardless of any prior, concurrent, or subsequent active or passive negligence by the Additional Insureds.

8. It is hereby agreed that the laws of the State of California shall apply to and govern the validity, construction, interpretation, and enforcement of this contract of insurance.

9. This endorsement and all notices given hereunder shall be sent to Public Agency at:

City Manager
City of Agoura Hills
City Hall
30001 Ladyface Court
Agoura Hills, California 91301

707 Except as stated above and not in conflict with this endorsement, nothing contained herein shall be held to waive, alter or extend any of the limits, agreements, or exclusions of the policy to which this endorsement is attached.

<u>TYPE OF COVERAGES TO WHICH THIS ENDORSEMENT ATTACHES</u>	<u>POLICY PERIOD FROM/TO</u>	<u>LIMITS OF LIABILITY</u>
---	------------------------------	----------------------------

11. Scheduled items or locations are to be identified on an attached sheet. The following inclusions relate to the above coverages. Includes:

- | | |
|-------------------------|-----------------------------|
| í Any Automobiles | í Truckers Coverage |
| í All Owned Automobiles | í Motor Carrier Act |
| í Non-owned Automobiles | í Bus Regulatory Reform Act |
| í Hired Automobiles | í Public Livery Coverage |
| í Scheduled Automobiles | í _____ |
| í Garage Coverage | í _____ |

12. A deductible or self-insured retention (*check one*) of \$ _____ applies to all coverage(s) except: _____ (*if none, so state*). The deductible is applicable G per claim or G per occurrence (*check one*).

13. This is an occurrence or claims made policy (*check one*).

14. This endorsement is effective on _____ at 12:01 a.m. and forms a part of Policy Number _____.

I, _____ (*print name*), hereby declare under penalty of perjury under the laws of the State of California, that I have the authority to bind the Company to this endorsement and that by my execution hereof, I do so bind the Company.

Executed _____, 20____

Telephone No.: (____) _____

Signature of Authorized Representative
(Original signature only; no facsimile signature
or initialed signature accepted)

ADDITIONAL INSURED ENDORSEMENT EXCESS LIABILITY

Name and address of named insured ("Named Insured"): _____

Name and address of Insurance Company ("Company"): _____

General description of agreement(s), permit(s), license(s), and/or activity(ies) insured:

Notwithstanding any inconsistent statement in the policy to which this endorsement is attached (the "Policy") or in any endorsement now or hereafter attached thereto, it is agreed as follows:

1. The City of Agoura Hills ("Public Agency"), its elected officials, officers, attorneys, agents, employees, and volunteers are additional insureds (the above named additional insureds are hereafter referred to as the "Additional Insureds") under the Policy in relation to those activities described generally above with regard to operations performed by or on behalf of the Named Insured. The Additional Insureds have no liability for the payment of any premiums or assessments under the Policy.

2. The insurance coverages afforded the Additional Insureds under the Policy shall be primary insurance, and no other insurance maintained by the Additional Insureds shall be called upon to contribute with the insurance coverages provided by the Policy.

3. Each insurance coverage under the Policy shall apply separately to each Additional Insured against whom claim is made or suit is brought, except with respect to the limits of the Company's liability.

4. Nothing in this contract of insurance shall be construed to preclude coverage of a claim by one insured under the policy against another insured under the policy. All such claims shall be covered as third-party claims, i.e., in the same manner as if separate policies had been issued to each insured. Nothing contained in this provision shall operate to increase or replicate the Company's limits of liability as provided under the policy.

5. The insurance afforded by the Policy for contractual liability insurance (subject to the terms, conditions and exclusions applicable to such insurance) includes liability assumed by the Named Insured under the indemnification and/or hold harmless provision(s) contained in or executed in conjunction with the written agreement(s) or permit(s) designated above, between the Named Insured and the Additional Insureds.

6. The policy to which this endorsement is attached shall not be subject to cancellation, change in coverage, reduction of limits (except as the result of the payment of claims), or non-renewal except after written notice to Public Agency, by certified mail, return receipt requested, not less than thirty (30) Days before the effective date thereto. In the event of Company's failure to comply with this notice provision, the policy as initially drafted will continue in full force and effect until compliance with this notice requirement.

7. Company hereby waives all rights of subrogation and contribution against the Additional Insureds, while acting within the scope of their duties, from all claims, losses and liabilities arising out of or incident to the perils insured against in relation to those activities described generally above with regard to operations performed by or on behalf of the Named Insured regardless of any prior, concurrent, or subsequent active or passive negligence by the Additional Insureds.

8. It is hereby agreed that the laws of the State of California shall apply to and govern the validity, construction, interpretation, and enforcement of this contract of insurance.

9. This endorsement and all notices given hereunder shall be sent to Public Agency at:

City Manager
City of Agoura Hills
City Hall
30001 Ladyface Court
Agoura Hills, California 91301

708 Except as stated above and not in conflict with this endorsement, nothing contained herein shall be held to waive, alter or extend any of the limits, agreements, or exclusions of the policy to which this endorsement is attached.

<u>TYPE OF COVERAGES TO WHICH THIS ENDORSEMENT ATTACHES</u>	<u>POLICY PERIOD FROM/TO</u>	<u>LIMITS OF LIABILITY</u>
---	------------------------------	----------------------------

- Following Form
- Umbrella Liability

11. Applicable underlying coverages:

<u>INSURANCE COMPANY</u>	<u>POLICY NO.</u>	<u>AMOUNT</u>
--------------------------	-------------------	---------------

12. The following inclusions, exclusions, extensions or specific provisions relate to the above coverages:

13. A deductible or self-insured retention (*check one*) of \$ _____ applies to all coverage(s) except: _____ (*if none, so state*). The deductible is applicable per claim or per occurrence (*check one*).

14. This is an occurrence or claims made policy (*check one*).

15. This endorsement is effective on _____ at 12:01 a.m. and forms a part of Policy Number _____.

I, _____ (*print name*), hereby declare under penalty of perjury under the laws of the State of California, that I have the authority to bind the Company to this endorsement and that by my execution hereof, I do so bind the Company.

Executed _____, 20__

Telephone No.: (____) _____

Signature of Authorized Representative
(Original signature only; no facsimile signature or initialed signature accepted)

CITY OF AGOURA HILLS

APPENDICES

APPENDIX A	CONSTRUCTION PLANS
APPENDIX B	LIST OF CITY-APPROVED HAULERS
APPENDIX C	PRE-QUALIFICATION QUESTIONS PACKAGE
APPENDIX D	ADA CURB RAMP STANDARD 111-4 CASE B TYPE 1
APPENDIX E	CDBG REQUIREMENTS AND FORMS
APPENDIX F	LOS ANGELES COUNTY FLOOD CONTROL PERMIT
APPENDIX G	LOS ANGELES COUNTY LIABILITY INSURANCE REQUIREMENTS
APPENDIX H	EXCEL BRIDGE ERECTING INSTRUCTIONS

APPENDIX A
CONSTRUCTION PLANS

APPENDIX B

LIST OF CITY-APPROVED HAULERS

City of Agoura Hills Permitted Waste Haulers 2018

Residential Franchises

Waste Management/G.I. Industries
 195 W. Los Angeles Ave.
 Simi Valley, CA 93065
 Michael Smith/Marilyn Gallagher
 805-955-4342 Fax 805-955-4363

Commercial/Roll-Off/Rent-a-Bin Collectors

<p>Anderson Rubbish * 4590 Industrial Street Simi Valley, CA 93063 Charles Anderson/Susan Anderson 805-526-1919 Fax 805-526-0311</p> <p>Consolidated Disposal Service RO/C&D Only 12949 Telegraph Road Santa Fe Springs, CA 90670 James Pledger 818-683-1616 Fax 818-402-2591</p> <p>EJ Harrisons & Sons Inc. RO/C&D Only 5275 Colt St Ventura, CA 93003 Daniel Harrison 805-647-1414; Fax 805-659-7219</p> <p>Interior Removal Specialist – RO Only 8990 Atlantic Ave South Gate, CA 90280 Carlos Herrera/Oscar Cisneros 323-357-6900 Fax 323-357-3400</p> <p>J&L Hauling and Disposal Inc. – RO/C&D Only P.O. Box 3035 Chatsworth, CA 91313 Juan Lopez/Martha Velasquez 818-470-9356; 818-470-9504;</p>	<p>Metropolis Disposal Inc – C&D Only 7740 Burnet Ave Van Nuys, CA 91405 Tina Eiseman/Jennifer Shaw 818-901-2020 Fax 818-778-1895</p> <p>Magnum Land Clearing Inc. – RO/C&D Only P.O. Box 3184 Chatsworth, CA 91313 Michael Turner 818-887-9222 Fax 818-887-5166</p> <p>Rock and Roll Off – C&D Only P.O. Box 144 Agoura Hills, CA 91376-0144 Eli Arviv/Raquel Sperling 818-991-2323 Fax 818-991-3258</p> <p>Universal Waste System Inc. * P.O. Box 3038 Whittier, CA 90605 Mark Blackburn/Michelle Newsham 562-205-4971 Fax 562-205-9237</p> <p>Waste Management/GI Industries * 195 W. Los Angeles Ave. Simi Valley, CA 93065 Marilyn Gallagher 805-955-4342 Fax 805-955-4377</p>
--	--

Legend: * These commercial collectors can provide business organics (food waste) collection. AB 1827 require businesses that generate more than 4 cubic yards of organic waste per week to implement an organics collection program.

RO/C&D Only – Temporary Roll Off & Construction and Demolition Only

NOTE: Roll-off & Rent-a-Bins providers are permitted to provide services in the residential area. However, regular residential trash, recycling and green waste services are NOT permitted. ONLY project type activity.

Check if Agent for Applicant

Print Name _____ Date _____
 Signature _____

I certify that I understand I must utilize use of a collector from this list for my temporary construction project roll-off and temporary bin needs. Use of other haulers is not permitted.

1/9/2018

APPENDIX C

PRE-QUALIFICATION QUESTIONS PACKAGE

PRE-QUALIFICATION QUESTIONS PACKAGE

Section (I)

Questions about History of the Business and Organizational Performance

1. How many years has your organization been in business in California as a contractor under your present business name and license number? _____ Years.
2. Is your firm currently the debtor in a bankruptcy case?
 Yes No
3. Was your firm in bankruptcy any time during the last five years? (This question refers only to a bankruptcy action that was not described in answer to question 7, above).
 Yes No
- 1.
4. Has any CSLB license held by your firm or its Responsible Managing Employee (RME) or Responsible Managing Officer (RMO) been suspended within the last five years?
 Yes No
5. At any time in the last five years, has your firm been assessed and paid liquidated damages after completion of a project, under a construction contract with either a public or private owner?
 Yes No
6. In the last five years has your firm, or any firm with which any of your company's owners, officers or partners was associated, been debarred, disqualified, removed or otherwise prevented from bidding on, or completing, any government agency or public works project for any reason?
NOTE: "Associated with" refers to another construction firm in which an owner, partner or officer of your firm held a similar position.
 Yes No
7. In the last five years, has your firm been denied an award of a public works contract based on a finding by a public agency that your company was not a responsible bidder?
 Yes No

* * * * *

NOTE: The following two questions refer only to disputes between your firm and the owner of a project. You need not include information about disputes between your firm and a supplier, another contractor, or subcontractor. You need not include information about "pass-through" disputes in which the actual dispute is between a sub-contractor and a project owner. Also, you may omit reference to all disputes about amounts of less than \$50,000.

8. In the past five years, has any claim **against** your firm concerning your firm's work on a construction project, been **filed in court or arbitration?**

Yes No

9. **In the past five years, has your firm made any claim against a project owner concerning work on a project or payment for a contract, and filed that claim in court or arbitration?**

Yes No

10. At any time during the past five years, has any surety company made any payments on your firm's behalf as a result of a default, to satisfy any claims made against a performance or payment bond issued on your firm's behalf in connection with a construction project, either public or private?

Yes No

11. In the last five years, has any insurance carrier, for any form of insurance, refused to renew the insurance policy for your firm?

Yes No

12. Has your firm or any of its owners, officers, or partners ever been found liable in a civil suit, or found guilty in a criminal action, for making any false claim or material misrepresentation to any public agency or entity?

Yes No

13. Has your firm or any of its owners, officers or partners ever been convicted of a crime involving any federal, state, or local law related to construction?

Yes No

14. Has your firm or any of its owners, officers or partners ever been convicted of a federal or state crime of fraud, theft, or any other act of dishonesty?

Yes No

15. If your firm was required to pay a premium of more than one per cent for a performance and payment bond on any project(s) on which your firm worked at any time during the last three years, state the percentage that your firm was required to pay. You may provide an explanation for a percentage rate higher than one per cent, if you wish to do so.

_____ %

16. During the last five years, has your firm ever been denied bond credit by a surety company, or has there ever been a period of time when your firm had no surety bond in place during a public construction project when one was required?

Yes No

2.

Section (II)

Questions about compliance with safety, workers compensation, prevailing wage and apprenticeship laws.

1. Has CAL OSHA cited and assessed penalties against your firm for any "serious," "willful" or "repeat" violations of its safety or health regulations in the past five years?

Note: If you have filed an appeal of a citation and the Occupational Safety and Health Appeals Board has not yet ruled on your appeal, you need not include information about it.

Yes No

2. Has the federal Occupational Safety and Health Administration cited and assessed penalties against your firm in the past five years?

Note: If you have filed an appeal of a citation and the appropriate appeals Board has not yet ruled on your appeal, you need not include information about it.

Yes No

If yes, attach a separate signed page describing each citation.

3. Has the EPA or any Air Quality Management District or any Regional Water Quality Control Board cited and assessed penalties against either your firm or the owner of a project on which your firm was the contractor, in the past five years?

NOTE: If you have filed an appeal of a citation and the Appeals Board has not yet ruled on your appeal, or if there is a court appeal pending, you need not include information about the citation.

Yes No

4. How often do you require documented safety meetings to be held for construction employees and field supervisors during the course of a project?

5. List your firm's Experience Modification Rate (EMR) (California workers' compensation insurance) for each of the past three premium years:

NOTE: An Experience Modification Rate is issued to your firm annually by your workers' compensation insurance carrier.

Current year: _____

Previous year: _____

Year prior to previous year: _____

If you're EMR for any of these three years is or was 1.00 or higher, you may, if you wish, attach a letter of explanation.

NOTE: An Experience Modification Rate is issued to your firm annually by your workers' compensation insurance carrier.

6. Within the last five years, has there ever been a period when your firm had employees but was without workers' compensation insurance or state-approved self-insurance?

Yes No

7. Has there been more than one occasion during the last five years on which your firm was required to pay either back wages or penalties for your own firm's failure to comply with the state's prevailing wage laws?

Yes No

NOTE: This question refers only to your own firm's violation of prevailing wage laws, not to violations of the prevailing wage laws by a subcontractor.

8. During the last five years, has there been more than one occasion on which your own firm has been penalized or required to pay back wages for failure to comply with the **federal Davis-Bacon prevailing wage requirements**?
 Yes No
9. Provide the **name, address and telephone number** of the apprenticeship program sponsor(s) (approved by the California Division of Apprenticeship Standards) that will provide apprentices to your company for use on any public work project for which you are awarded a contract by *[Public Entity]*.
-
-
10. If your firm operates its own State-approved apprenticeship program:
- (a) Identify the craft or crafts in which your firm provided apprenticeship training in the past year.
 - (b) State the year in which each such apprenticeship program was approved, and attach evidence of the most recent California Apprenticeship Council approval(s) of your apprenticeship program(s).
 - (c) State the number of individuals who were employed by your firm as apprentices at any time during the past three years in each apprenticeship and the number of persons who, during the past three years, completed apprenticeships in each craft while employed by your firm.
11. At any time during the last five years, has your firm been found to have violated any provision of California apprenticeship laws or regulations, or the laws pertaining to use of apprentices on public works?
NOTE: You may omit reference to any incident that occurred prior to January 1, 1998 if the violation was by a subcontractor and your firm, as general contractor on a project, had no knowledge of the subcontractor's violation at the time they occurred.
 Yes No.
 If yes, provide the date(s) of such findings, and attach copies of the Department's final decision(s).

Section (III)

Questions concerning recent construction projects completed:

The following question to be scored only where a public agency is undertaking a pre-qualification procedure valid for a single project only.

1. Contractor shall provide information about its six most recently completed public works projects and its three largest completed private projects within the last three years ¹. Names and references must be current and verifiable. Use separate sheets of paper that contain all of the following information:

Project Name: _____
Location: _____
Owner: _____
Owner Contact (name and current phone number):

Architect or Engineer: _____

Architect or Engineer Contact (name and current phone number):

Construction Manager (name and current phone number):

Description of Project, Scope of Work Performed:

Total Value of Construction (including change orders): _____

Original Scheduled Completion Date: _____

Time Extensions Granted (number of days): _____

Actual Date of Completion: _____

¹ If you wish, you may, using the same format, also provide information about other projects that you have completed that are similar to the project(s) for which you expect to bid.

APPENDIX D

ADA CURB RAMP STANDARD 111-4 CASE B TYPE 1

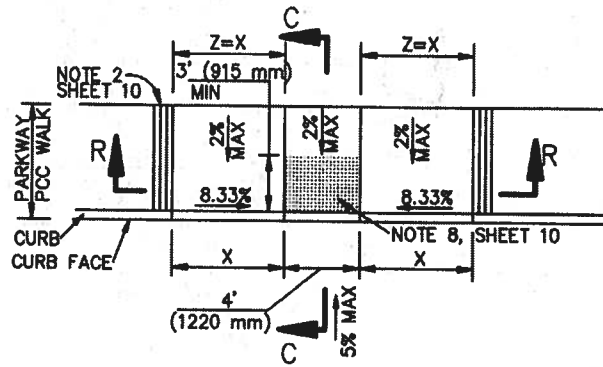

TYPE 1

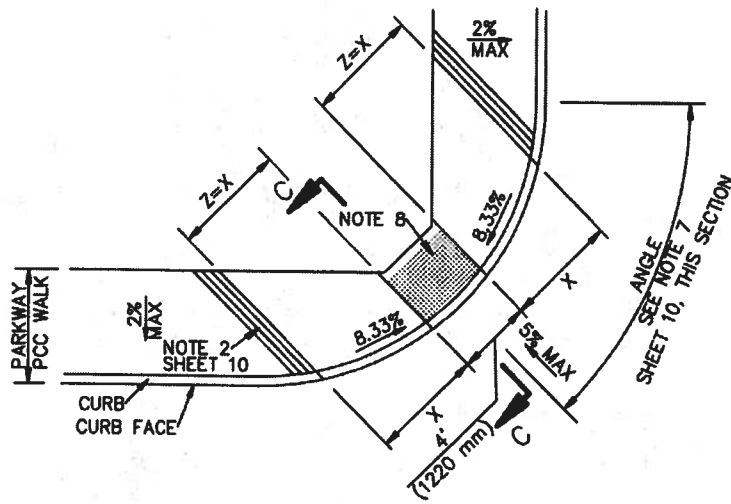

TYPE 2
CASE B

STANDARD PLANS FOR PUBLIC WORKS CONSTRUCTION	STANDARD PLAN
CURB RAMP	111-4
	SHEET 4 OF 10

APPENDIX E

CDBG REQUIREMENTS AND FORMS

**Federally Assisted Project
U.S. Department of Housing and Urban Development**

- Exhibit 1 Summary of Contract Provisions for Inclusion in the Notice Inviting Bids
- Exhibit 2 Federal Labor Standards Provisions – HUD-4010
- Exhibit 3 Federal Equal Employment Opportunity / Affirmative Action Provisions
- Exhibit 4 Contracting With Small Business, Minority Firms, Women's Business Enterprise, and Labor Surplus Area Firms
- Exhibit 5 Worker's Compensation Certification
- Exhibit 6 List of Proposed Subcontractors or Sub-Tier Contractors
- Exhibit 7 Certification of Understanding and Authorization
- Exhibit 8 Request for Additional Classification and Rate
- Exhibit 9 Non-Segregated Facilities Certification
- Exhibit 10 Past Performance Certification
- Exhibit 11 Notice of Equal Employment Opportunity
- Exhibit 12 Minority and Women's Business Enterprise Tierd Compliance Plan
- Exhibit 13 County Lobbyist Certification
- Exhibit 14 Fringe Benefit Statement
- Exhibit 15 Payroll Report & Statement of Compliance
- Exhibit 16 Agency Report of Contract Award
- Exhibit 17 Federal Wage Decision

EXHIBIT 1

Summary of Contract Provisions for Inclusion in the Notice Inviting Bids

Prevailing Wage Statement: This contract will be funded in whole or in part with federal housing and community development funds. The Federal Labor Standards Provisions, including prevailing wage requirements of the Davis-Bacon and Related Acts will be enforced. A copy of the Federal Wage Decision applicable to this project is included in the Bid Document.

This project is a public work in the State of California, funded in whole or in part with public funds. Therefore, the higher of the two applicable prevailing wage rates, federal or state, will be enforced. The Contractor's duty to pay State prevailing wages can be found under Labor Code Section 1770 et seq. Labor Code Sections 1775 and 1777.7 outline the penalties for failure to pay prevailing wages and to employ apprentices, including forfeitures and debarment. The State Wage Decision is on file at the City Clerk's office, and is also available online at <http://www.dir.ca.gov/dlsr/>.

Apprenticeship Program: Attention is directed to Sections 1777.5, 1777.6 and 1777.7 of the California Labor Code and Title 8, California Administrative code, Section 200 et seq. to ensure compliance and complete understanding of the law regarding apprentices.

Minority and Women Owned Business: Bidders will be required to document their status as a Minority Business Enterprise (MBE), a Women-owned Business Enterprise (WBE) or a non-MBE/WBE firm. Bidders that are not MBE/WBE firms will be required to make a good faith effort, and to document their efforts to include firms as part of the contract bid.

Conflict of Interest: In the procurement of supplies, equipment, construction, and services by sub-recipients, the conflict of interest provisions in (State LCA - 24 CFR 85.36 and Non-Profit Organizations - 24 CFR 84.4), OMB Circular A-110, and 24 CFR 570.611, respectively, shall apply. No employee, officer or agent of the sub-recipient shall participate in selection, or in the award or administration of a contract supported by Federal funds if a conflict of interest, real or apparent, would be involved.

EXHIBIT 2

Federal Labor Standards Provisions

(Next Page)

Applicability

The Project or Program to which the construction work covered by this contract pertains is being assisted by the United States of America and the following Federal Labor Standards Provisions are included in this Contract pursuant to the provisions applicable to such Federal assistance.

A. 1. (i) Minimum Wages. All laborers and mechanics employed or working upon the site of the work, will be paid unconditionally and not less often than once a week, and without subsequent deduction or rebate on any account (except such payroll deductions as are permitted by regulations issued by the Secretary of Labor under the Copeland Act (29 CFR Part 3), the full amount of wages and bona fide fringe benefits (or cash equivalents thereof) due at time of payment computed at rates not less than those contained in the wage determination of the Secretary of Labor which is attached hereto and made a part hereof, regardless of any contractual relationship which may be alleged to exist between the contractor and such laborers and mechanics. Contributions made or costs reasonably anticipated for bona fide fringe benefits under Section 1(b)(2) of the Davis-Bacon Act on behalf of laborers or mechanics are considered wages paid to such laborers or mechanics, subject to the provisions of 29 CFR 5.5(a)(1)(iv); also, regular contributions made or costs incurred for more than a weekly period (but not less often than quarterly) under plans, funds, or programs, which cover the particular weekly period, are deemed to be constructively made or incurred during such weekly period.

Such laborers and mechanics shall be paid the appropriate wage rate and fringe benefits on the wage determination for the classification of work actually performed, without regard to skill, except as provided in 29 CFR 5.5(a)(4). Laborers or mechanics performing work in more than one classification may be compensated at the rate specified for each classification for the time actually worked therein: Provided, That the employer's payroll records accurately set forth the time spent in each classification in which work is performed. The wage determination (including any additional classification and wage rates conformed under 29 CFR 5.5(a)(1)(ii) and the Davis-Bacon poster (WH-1321) shall be posted at all times by the contractor and its subcontractors at the site of the work in a prominent and accessible, place where it can be easily seen by the workers.

(ii) (a) Any class of laborers or mechanics which is not listed in the wage determination and which is to be employed under the contract shall be classified in conformance with the wage determination. HUD shall approve an additional classification and wage rate and fringe benefits therefor only when the following criteria have been met:

(1) The work to be performed by the classification requested is not performed by a classification in the wage determination; and

(2) The classification is utilized in the area by the construction industry; and

(3) The proposed wage rate, including any bona fide fringe benefits, bears a reasonable relationship to the wage rates contained in the wage determination.

(b) If the contractor and the laborers and mechanics to be employed in the classification (if known), or their representatives, and HUD or its designee agree on the classification and wage rate (including the amount designated for fringe benefits where appropriate), a report of the action taken shall be sent by HUD or its designee to the Administrator of the Wage and Hour Division, Employment Standards Administration, U.S. Department of Labor, Washington, D.C. 20210. The Administrator, or an authorized representative, will approve, modify, or disapprove every additional classification action within 30 days of receipt and so advise HUD or its designee or will notify HUD or its designee within the 30-day period that additional time is necessary. (Approved by the Office of Management and Budget under OMB control number 1215-0140.)

(c) In the event the contractor, the laborers or mechanics to be employed in the classification or their representatives, and HUD or its designee do not agree on the proposed classification and wage rate (including the amount designated for fringe benefits, where appropriate), HUD or its designee shall refer the questions, including the views of all interested parties and the recommendation of HUD or its designee, to the Administrator for determination. The Administrator, or an authorized representative, will issue a determination within 30 days of receipt and so advise HUD or its designee or will notify HUD or its designee within the 30-day period that additional time is necessary. (Approved by the Office of Management and Budget under OMB Control Number 1215-0140.)

(d) The wage rate (including fringe benefits where appropriate) determined pursuant to subparagraphs (1)(ii)(b) or (c) of this paragraph, shall be paid to all workers performing work in the classification under this contract from the first day on which work is performed in the classification.

(iii) Whenever the minimum wage rate prescribed in the contract for a class of laborers or mechanics includes a fringe benefit which is not expressed as an hourly rate, the contractor shall either pay the benefit as stated in the wage determination or shall pay another bona fide fringe benefit or an hourly cash equivalent thereof.

(iv) If the contractor does not make payments to a trustee or other third person, the contractor may consider as part

of the wages of any laborer or mechanic the amount of any costs reasonably anticipated in providing bona fide fringe benefits under a plan or program, Provided, That the Secretary of Labor has found, upon the written request of the contractor, that the applicable standards of the Davis-Bacon Act have been met. The Secretary of Labor may require the contractor to set aside in a separate account assets for the meeting of obligations under the plan or program. (Approved by the Office of Management and Budget under OMB Control Number 1215-0140.)

2. Withholding. HUD or its designee shall upon its own action or upon written request of an authorized representative of the Department of Labor withhold or cause to be withheld from the contractor under this contract or any other Federal contract with the same prime contractor, or any other Federally-assisted contract subject to Davis-Bacon prevailing wage requirements, which is held by the same prime contractor so much of the accrued payments or advances as may be considered necessary to pay laborers and mechanics, including apprentices, trainees and helpers, employed by the contractor or any subcontractor the full amount of wages required by the contract. In the event of failure to pay any laborer or mechanic, including any apprentice, trainee or helper, employed or working on the site of the work, all or part of the wages required by the contract, HUD or its designee may, after written notice to the contractor, sponsor, applicant, or owner, take such action as may be necessary to cause the suspension of any further payment, advance, or guarantee of funds until such violations have ceased. HUD or its designee may, after written notice to the contractor, disburse such amounts withheld for and on account of the contractor or subcontractor to the respective employees to whom they are due. The Comptroller General shall make such disbursements in the case of direct Davis-Bacon Act contracts.

3. (i) Payrolls and basic records. Payrolls and basic records relating thereto shall be maintained by the contractor during the course of the work preserved for a period of three years thereafter for all laborers and mechanics working at the site of the work. Such records shall contain the name, address, and social security number of each such worker, his or her correct classification, hourly rates of wages paid (including rates of contributions or costs anticipated for bona fide fringe benefits or cash equivalents thereof of the types described in Section 1(b)(2)(B) of the Davis-bacon Act), daily and weekly number of hours worked, deductions made and actual wages paid. Whenever the Secretary of Labor has found under 29 CFR 5.5 (a)(1)(iv) that the wages of any laborer or mechanic include the amount of any costs reasonably anticipated in providing benefits under a plan or program described in Section 1(b)(2)(B) of the Davis-Bacon Act, the contractor shall maintain records which show that the commitment to provide such benefits is enforceable, that the plan or program is financially responsible, and that the plan or program has been

communicated in writing to the laborers or mechanics affected, and records which show the costs anticipated or the actual cost incurred in providing such benefits. Contractors employing apprentices or trainees under approved programs shall maintain written evidence of the registration of apprenticeship programs and certification of trainee programs, the registration of the apprentices and trainees, and the ratios and wage rates prescribed in the applicable programs. (Approved by the Office of Management and Budget under OMB Control Numbers 1215-0140 and 1215-0017.)

(ii) (a) The contractor shall submit weekly for each week in which any contract work is performed a copy of all payrolls to HUD or its designee if the agency is a party to the contract, but if the agency is not such a party, the contractor will submit the payrolls to the applicant sponsor, or owner, as the case may be, for transmission to HUD or its designee. The payrolls submitted shall set out accurately and completely all of the information required to be maintained under 29 CFR 5.5(a)(3)(i) except that full social security numbers and home addresses shall not be included on weekly transmittals. Instead the payrolls shall only need to include an individually identifying number for each employee (e.g., the last four digits of the employee's social security number). The required weekly payroll information may be submitted in any form desired. Optional Form WH-347 is available for this purpose from the Wage and Hour Division [Web site at http://www.dol.gov/esa/whd/forms/wh347instr.htm](http://www.dol.gov/esa/whd/forms/wh347instr.htm) or its successor site. The prime contractor is responsible for the submission of copies of payrolls by all subcontractors. Contractors and subcontractors shall maintain the full social security number and current address of each covered worker, and shall provide them upon request to HUD or its designee if the agency is a party to the contract, but if the agency is not such a party, the contractor will submit the payrolls to the applicant sponsor, or owner, as the case may be, for transmission to HUD or its designee, the contractor, or the Wage and Hour Division of the Department of Labor for purposes of an investigation or audit of compliance with prevailing wage requirements. It is not a violation of this subparagraph for a prime contractor to require a subcontractor to provide addresses and social security numbers to the prime contractor for its own records, without weekly submission to HUD or its designee. (Approved by the Office of Management and Budget under OMB Control Number 1215-0149.)

(b) Each payroll submitted shall be accompanied by a "Statement of Compliance," signed by the contractor or subcontractor or his or her agent who pays or supervises the payment of the persons employed under the contract and shall certify the following:

(1) That the payroll for the payroll period contains the information required to be provided under 29 CFR 5.5 (a)(3)(ii), the appropriate information is being maintained under 29 CFR 5.5(a)(3)(i), and that such information is correct and complete;

(2) That each laborer or mechanic (including each helper, apprentice, and trainee) employed on the contract during the payroll period has been paid the full weekly wages earned, without rebate, either directly or indirectly, and that no deductions have been made either directly or indirectly from the full wages earned, other than permissible deductions as set forth in 29 CFR Part 3;

(3) That each laborer or mechanic has been paid not less than the applicable wage rates and fringe benefits or cash equivalents for the classification of work performed, as specified in the applicable wage determination incorporated into the contract.

(c) The weekly submission of a properly executed certification set forth on the reverse side of Optional Form WH-347 shall satisfy the requirement for submission of the "Statement of Compliance" required by subparagraph A.3.(ii)(b).

(d) The falsification of any of the above certifications may subject the contractor or subcontractor to civil or criminal prosecution under Section 1001 of Title 18 and Section 231 of Title 31 of the United States Code.

(iii) The contractor or subcontractor shall make the records required under subparagraph A.3.(i) available for inspection, copying, or transcription by authorized representatives of HUD or its designee or the Department of Labor, and shall permit such representatives to interview employees during working hours on the job. If the contractor or subcontractor fails to submit the required records or to make them available, HUD or its designee may, after written notice to the contractor, sponsor, applicant or owner, take such action as may be necessary to cause the suspension of any further payment, advance, or guarantee of funds. Furthermore, failure to submit the required records upon request or to make such records available may be grounds for debarment action pursuant to 29 CFR 5.12.

4. Apprentices and Trainees.

(i) **Apprentices.** Apprentices will be permitted to work at less than the predetermined rate for the work they performed when they are employed pursuant to and individually registered in a bona fide apprenticeship program registered with the U.S. Department of Labor, Employment and Training Administration, Office of Apprenticeship Training, Employer and Labor Services, or with a State Apprenticeship Agency recognized by the Office, or if a person is employed in his or her first 90 days of probationary employment as an apprentice in such an apprenticeship program, who is not individually registered in the program, but who has been certified by the Office of Apprenticeship Training, Employer and Labor Services or a State Apprenticeship Agency (where appropriate) to be eligible for probationary employment as an apprentice. The allowable ratio of apprentices to journeymen on the job site in any craft classification shall not be greater than the ratio permitted to the contractor as to the entire work force under the registered program. Any worker listed on a payroll at an apprentice wage rate, who

is not registered or otherwise employed as stated above, shall be paid not less than the applicable wage rate on the wage determination for the classification of work actually performed. In addition, any apprentice performing work on the job site in excess of the ratio permitted under the registered program shall be paid not less than the applicable wage rate on the wage determination for the work actually performed. Where a contractor is performing construction on a project in a locality other than that in which its program is registered, the ratios and wage rates (expressed in percentages of the journeyman's hourly rate) specified in the contractor's or subcontractor's registered program shall be observed. Every apprentice must be paid at not less than the rate specified in the registered program for the apprentice's level of progress, expressed as a percentage of the journeymen hourly rate specified in the applicable wage determination. Apprentices shall be paid fringe benefits in accordance with the provisions of the apprenticeship program. If the apprenticeship program does not specify fringe benefits, apprentices must be paid the full amount of fringe benefits listed on the wage determination for the applicable classification. If the Administrator determines that a different practice prevails for the applicable apprentice classification, fringes shall be paid in accordance with that determination. In the event the Office of Apprenticeship Training, Employer and Labor Services, or a State Apprenticeship Agency recognized by the Office, withdraws approval of an apprenticeship program, the contractor will no longer be permitted to utilize apprentices at less than the applicable predetermined rate for the work performed until an acceptable program is approved.

(ii) **Trainees.** Except as provided in 29 CFR 5.16, trainees will not be permitted to work at less than the predetermined rate for the work performed unless they are employed pursuant to and individually registered in a program which has received prior approval, evidenced by formal certification by the U.S. Department of Labor, Employment and Training Administration. The ratio of trainees to journeymen on the job site shall not be greater than permitted under the plan approved by the Employment and Training Administration. Every trainee must be paid at not less than the rate specified in the approved program for the trainee's level of progress, expressed as a percentage of the journeyman hourly rate specified in the applicable wage determination. Trainees shall be paid fringe benefits in accordance with the provisions of the trainee program. If the trainee program does not mention fringe benefits, trainees shall be paid the full amount of fringe benefits listed on the wage determination unless the Administrator of the Wage and Hour Division determines that there is an apprenticeship program associated with the corresponding journeyman wage rate on the wage determination which provides for less than full fringe benefits for apprentices. Any employee listed on the payroll at a trainee rate who is not registered and participating in a training plan approved by

the Employment and Training Administration shall be paid not less than the applicable wage rate on the wage determination for the work actually performed. In addition, any trainee performing work on the job site in excess of the ratio permitted under the registered program shall be paid not less than the applicable wage rate on the wage determination for the work actually performed. In the event the Employment and Training Administration withdraws approval of a training program, the contractor will no longer be permitted to utilize trainees at less than the applicable predetermined rate for the work performed until an acceptable program is approved.

(iii) Equal employment opportunity. The utilization of apprentices, trainees and journeymen under 29 CFR Part 5 shall be in conformity with the equal employment opportunity requirements of Executive Order 11246, as amended, and 29 CFR Part 30.

5. Compliance with Copeland Act requirements. The contractor shall comply with the requirements of 29 CFR Part 3 which are incorporated by reference in this contract

6. Subcontracts. The contractor or subcontractor will insert in any subcontracts the clauses contained in subparagraphs 1 through 11 in this paragraph A and such other clauses as HUD or its designee may by appropriate instructions require, and a copy of the applicable prevailing wage decision, and also a clause requiring the subcontractors to include these clauses in any lower tier subcontracts. The prime contractor shall be responsible for the compliance by any subcontractor or lower tier subcontractor with all the contract clauses in this paragraph.

7. Contract termination; debarment. A breach of the contract clauses in 29 CFR 5.5 may be grounds for termination of the contract and for debarment as a contractor and a subcontractor as provided in 29 CFR 5.12.

8. Compliance with Davis-Bacon and Related Act Requirements. All rulings and interpretations of the Davis-Bacon and Related Acts contained in 29 CFR Parts 1, 3, and 5 are herein incorporated by reference in this contract

9. Disputes concerning labor standards. Disputes arising out of the labor standards provisions of this contract shall not be subject to the general disputes clause of this contract. Such disputes shall be resolved in accordance with the procedures of the Department of Labor set forth in 29 CFR Parts 5, 6, and 7. Disputes within the meaning of this clause include disputes between the contractor (or any of its subcontractors) and HUD or its designee, the U.S. Department of Labor, or the employees or their representatives.

10. (i) Certification of Eligibility. By entering into this contract the contractor certifies that neither it (nor he or she) nor any person or firm who has an interest in the contractor's firm is a person or firm ineligible to be awarded Government contracts by virtue of Section 3(a) of the Davis-Bacon Act or 29 CFR 5.12(a)(1) or to be

awarded HUD contracts or participate in HUD programs pursuant to 24 CFR Part 24.

(ii) No part of this contract shall be subcontracted to any person or firm ineligible for award of a Government contract by virtue of Section 3(a) of the Davis-Bacon Act or 29 CFR 5.12(a)(1) or to be awarded HUD contracts or participate in HUD programs pursuant to 24 CFR Part 24.

(iii) The penalty for making false statements is prescribed in the U.S. Criminal Code, 18 U.S.C. 1001. Additionally, U.S. Criminal Code, Section 1 01 0, Title 18, U.S.C., "Federal Housing Administration transactions", provides in part: "Whoever, for the purpose of . . . influencing in any way the action of such Administration..... makes, utters or publishes any statement knowing the same to be false..... shall be fined not more than \$5,000 or imprisoned not more than two years, or both."

11. Complaints, Proceedings, or Testimony by Employees. No laborer or mechanic to whom the wage, salary, or other labor standards provisions of this Contract are applicable shall be discharged or in any other manner discriminated against by the Contractor or any subcontractor because such employee has filed any complaint or instituted or caused to be instituted any proceeding or has testified or is about to testify in any proceeding under or relating to the labor standards applicable under this Contract to his employer.

B. Contract Work Hours and Safety Standards Act. The provisions of this paragraph B are applicable where the amount of the prime contract exceeds \$100,000. As used in this paragraph, the terms "laborers" and "mechanics" include watchmen and guards.

(1) Overtime requirements. No contractor or subcontractor contracting for any part of the contract work which may require or involve the employment of laborers or mechanics shall require or permit any such laborer or mechanic in any workweek in which the individual is employed on such work to work in excess of 40 hours in such workweek unless such laborer or mechanic receives compensation at a rate not less than one and one-half times the basic rate of pay for all hours worked in excess of 40 hours in such workweek.

(2) Violation; liability for unpaid wages; liquidated damages. In the event of any violation of the clause set forth in subparagraph (1) of this paragraph, the contractor and any subcontractor responsible therefor shall be liable for the unpaid wages. In addition, such contractor and subcontractor shall be liable to the United States (in the case of work done under contract for the District of Columbia or a territory, to such District or to such territory), for liquidated damages. Such liquidated damages shall be computed with respect to each individual laborer or mechanic, including watchmen and guards, employed in violation of the clause set forth in subparagraph (1) of this paragraph, in the sum of \$10 for each calendar day on which such individual was required or permitted to work in excess of the standard workweek of 40 hours without payment of the overtime wages required by the clause set forth in sub paragraph (1) of this paragraph.

(3) Withholding for unpaid wages and liquidated damages. HUD or its designee shall upon its own action or upon written request of an authorized representative of the Department of Labor withhold or cause to be withheld, from any moneys payable on account of work performed by the contractor or subcontractor under any such contract or any other Federal contract with the same prime contract, or any other Federally-assisted contract subject to the Contract Work Hours and Safety Standards Act which is held by the same prime contractor such sums as may be determined to be necessary to satisfy any liabilities of such contractor or subcontractor for unpaid wages and liquidated damages as provided in the clause set forth in subparagraph (2) of this paragraph.

(4) Subcontracts. The contractor or subcontractor shall insert in any subcontracts the clauses set forth in subparagraph (1) through (4) of this paragraph and also a clause requiring the subcontractors to include these clauses in any lower tier subcontracts. The prime contractor shall be responsible for compliance by any subcontractor or lower tier subcontractor with the clauses set forth in subparagraphs (1) through (4) of this paragraph.

C. Health and Safety. The provisions of this paragraph C are applicable where the amount of the prime contract exceeds \$100,000.

(1) No laborer or mechanic shall be required to work in surroundings or under working conditions which are unsanitary, hazardous, or dangerous to his health and safety as determined under construction safety and health standards promulgated by the Secretary of Labor by regulation.

(2) The Contractor shall comply with all regulations issued by the Secretary of Labor pursuant to Title 29 Part 1926 and failure to comply may result in imposition of sanctions pursuant to the Contract Work Hours and Safety Standards Act, (Public Law 91-54, 83 Stat 96). 40 USC 3701 et seq.

(3) The contractor shall include the provisions of this paragraph in every subcontract so that such provisions will be binding on each subcontractor. The contractor shall take such action with respect to any subcontractor as the Secretary of Housing and Urban Development or the Secretary of Labor shall direct as a means of enforcing such provisions.

EXHIBIT 3

Federal Equal Employment Opportunity / Affirmative Action Provisions

1. **EQUAL OPPORTUNITY CLAUSE.** During the performance of this contract, the contractor agrees as follows:
 - a. The contractor will not discriminate against any employee or applicant for employment because of race, color, religion, sex, or national origin. The contractor will take affirmative action to ensure that applicants are employed, and that employees are treated during employment without regard to their race, color, religion, sex, or national origin. Such action shall include, but not be limited to the following: employment, upgrading, demotion, or transfer; recruitment or recruitment advertising; layoff or termination; rates of pay or other forms of compensation; and selection for training, including apprenticeship. The contractor agrees to post in conspicuous places, available to employees and applicants for employment, notices to be provided setting forth the provisions of this nondiscrimination clause.
 - b. The contractor will, in all solicitations or advertisements for employees placed by or on behalf of the contractor, state that all qualified applicants will receive consideration for employment without regard to race, color, religion, sex, or national origin.
 - c. The contractor will send to each labor union or representative of workers with which he/she has a collective bargaining agreement or other contract or understanding, a notice to be provided, advising the said labor union or workers' representative of the contractor's commitments under this section, and shall post copies of the notice in conspicuous places available to employees and applicants for employment.
 - d. The contractor will comply with all provisions of Executive Order 11246 of September 24, 1965, and of the rules, regulations, and relevant orders of the Secretary of Labor.
 - e. The contractor will furnish all information and reports required by Executive Order 11246 of September 24, 1965, and by the rules, regulations, and orders of the Secretary of Labor, or pursuant thereto, and will permit access to his/her books, records, and accounts by the administering agency and the Secretary of Labor for purposes of investigation to ascertain compliance with such rules, regulations, and orders.
 - f. In the event of the contractor's noncompliance with the nondiscrimination clause of this contract or with any of the said rules, regulations, or orders, this contract may be canceled, terminated, or suspended in whole, or in part, and the contractor may be declared ineligible for further government contracts or federally assisted construction contracts in accordance with procedures authorized in Executive Order 11246 of September 24, 1965, or by rule, regulation, or order of the Secretary of Labor, or as otherwise provided by law.
 - g. The contractor will include the provisions of Paragraph 1a through 1g in every subcontract or purchase order unless exempted by rule, regulations, or orders of

the Secretary of Labor issued pursuant to Section 204 of Executive Order 11246 of September 24, 1965, so that such provisions will be binding upon each subcontractor or vendor. The contractor will take such action with respect to any subcontract or purchase order as the administering agency may direct as a means of enforcing such provisions, including sanctions for noncompliance. Provided, however, that in the event a contractor becomes involved in, or is threatened with, litigation with a subcontractor or vendor as a result of such direction by the administering agency, the contractor may request the United States to enter into such litigation to protect the interests of the United States.

2. **NOTICE OF REQUIREMENT FOR AFFIRMATIVE ACTION TO ENSURE EQUAL EMPLOYMENT OPPORTUNITY** (Executive Order 11246)

- a. The Offeror's or Bidder's attention is called to the Equal Opportunity Clause and the Standard Federal Equal Employment Specifications set forth herein.
- b. The goals and timetables for minority and female participation, expressed in percentage terms for the contractor's aggregated work force in each trade on all construction work in the covered area, are as follows:

Timetables

Location of Work by Standard Metropolitan Statistical Area (SMSA)	Goals for Minority Participation in Each Trade	Goals for Female Participation in Each Trade
0360 Anaheim-Santa Ana-Garden Grove, CA	11.9%	6.9%
4480 Los Angeles-Long Beach, CA	28.3%	6.9%
6000 Oxnard-Simi Valley-Ventura, CA	21.5%	6.9%
6780 Riverside-San Bernardino-Ontario, CA	19.0%	6.9%
7480 Santa Barbara-Santa Maria-Lompoc, CA	19.7%	6.9%
7320 San Diego, CA	16.9%	6.9%
6920 Sacramento, CA	16.1%	6.9%
8520 Tucson, Pima AZ	24.1%	6.9%
6200 Phoenix, Maricopa AZ	15.8%	6.9%

These goals are applicable to all the contractor's construction work (whether or not it is Federal or federally assisted) performed in the covered area. If the contractor performs construction work in a geographical area located outside of the covered area, it shall apply the goals established for such geographical area where the work is actually performed. With regard to this second area, the contractor also is subject to the goals for both its federally involved and non-federally involved construction.

The contractor's compliance with the Executive Order and the regulations in 41 CFR Part 60-4 shall be based on its implementation of the Equal Opportunity Clause, specific affirmative action obligations required by the specifications set forth in 41 CFR Part 60-4.3(a), and its efforts to meet the goals. The hours of minority and female employment and training must be substantially uniform throughout the length of the contract and in each trade, and the contractor shall make a good faith effort to employ minorities and women evenly on each of its projects. The transfer of minority or female employees or trainees from contractor to contractor or from project to project for the sole purpose of meeting the contractor's goals shall be a violation of the contract, the Executive

Order, and the regulations of 41 CFR Part 60-4. Compliance with the goals will be measured against the total work hours performed.

- c. The contractor shall provide written notification to the Director of the Office of Federal Contract Compliance Programs within ten (10) working days of award of any construction subcontract in excess of \$10,000 at any tier for construction work under the contract resulting from this solicitation. The notification shall list the name, address, and telephone number of the subcontractor; employer identification number of the subcontractor; estimated dollar amount of the subcontract; estimated starting and completion dates of the subcontract; and the geographical area in which the contract is to be performed.
- d. As used in this notice, and in the contract resulting from this solicitation, the covered area is the Standard Metropolitan Statistical Area of Los Angeles-Long Beach, specifically the County of Los Angeles, State of California.

3. **STANDARD FEDERAL EQUAL EMPLOYMENT SPECIFICATIONS** (Executive Order 11246).

- a. As used in these specifications:
 - (1) Covered area means the geographical area described in the solicitation from which this contract resulted;
 - (2) Director means Director, Office of Federal Contract Compliance Programs, United States Department of Labor, or any person to whom the Director delegates authority;
 - (3) Employer Identification Number (EIN) means the Federal Social Security Number used on the Employer's Quarterly Federal Tax Return, United States Treasury Department Form 941.
 - (4) Minority includes:
 - (a) Black (all persons having origins in any of the Black African racial groups not of Hispanic origin)
 - (b) Hispanic (all persons of Mexican, Puerto Rican, Cuban, Central or South American or other Spanish culture or origin, regardless of race);
 - (c) Asian and Pacific Islander (all persons having origins in any of the original peoples of the Far East, Southeast Asia, the Indian Subcontinent, or the Pacific Islands); and
 - (d) American Indian or Alaskan Native (all persons having origins in any of the original peoples of North America and maintaining identifiable tribal affiliations through membership and participation or community identification).
- b. Whenever the contractor, or any subcontractor at any tier, subcontracts a portion of the work involving any construction trade, it shall physically include in each subcontract in excess of \$10,000 the provisions of these specifications and

the notice which contains the applicable goals for minority and female participation and which is set forth in the solicitations from which this contract resulted.

- c. If the contractor is participating (pursuant to 41 CFR Part 60-4.5) in a Hometown Plan approved by the United States Department of Labor in the covered area either individually or through an association, its affirmative action obligations on all work in the Plan area (including goals and time tables) shall be in accordance with that Plan for those trades which have unions participating in the Plan. Contractors must be able to demonstrate their participation in and compliance with the provisions of any such Hometown Plan. Each contractor or subcontractor participating in an approved Plan is individually required to comply with its obligations under the EEO Clause, and to make a good faith effort to achieve each goal under the Plan in each trade in which it has employees. The overall good faith performance by other contractors or subcontractors toward a goal in an approved Plan does not excuse any covered contractor's or subcontractor's failure to take good faith efforts to achieve the Plan goals and timetables.
- d. The contractor shall implement the specific affirmative action standards provided in paragraphs 3g (1) through 3g (16) of these specifications. The goals set forth in the solicitation from which this contract resulted are expressed as percentages of the total hours of employment and training of minority and female utilization the contractor should reasonable be able to achieve in each construction trade in which it has employees in the covered area. Covered construction contractors performing construction work in geographical areas where they do not have a Federal or federally assisted construction contract shall apply the minority and female goals established for the geographical area where the work is being performed. Goals are published periodically in the Federal Register in notice form, and such notices may be obtained from any Office of Federal Contract Compliance Programs office or from Federal procurement contracting officers. The contractor is expected to make substantially uniform progress in meeting its goals in each craft during the period specified.
- e. Neither the provisions of any collective bargaining agreement nor the failure by a union with whom the contractor has a collective bargaining agreement, to refer either minority or women shall excuse the contractor's obligations under these specifications, Executive Order 11246, or the regulations promulgated pursuant thereto.
- f. In order for the nonworking training hours of apprentices and trainees to be counted in meeting the goals, such apprentices and trainees must be employed by the contractor during the training period, and the contractor must have made a commitment to employ the apprentices and trainees at the completion of their training, subject to the availability of employment opportunities. Trainees must be trained pursuant to training programs approved by the United States Department of Labor.
- g. The contractor shall take specific affirmative actions to ensure equal employment opportunity. The evaluation of the contractor's compliance with these specifications shall be based upon its effort to achieve maximum results from its

actions. The contractor shall document these efforts fully, and shall implement affirmative action steps at least as extensive as the following:

- (1) Ensure and maintain working environment free of harassment, intimidation, and coercion at all sites, and in all facilities at which the contractor's employees are assigned to work. The contractor, where possible, will assign two or more women to each construction project. The contractor shall specifically ensure that all foremen, superintendents, and other on-site supervisory personnel are aware of and carry out the contractor's obligation to maintain such a working environment, with specific attention to minority or female individuals working at such sites or in such facilities.
- (2) Establish and maintain a current list of minority and female recruitment sources, provide written notification to minority and female recruitment sources and to community organizations when the contractor or its unions have employment opportunities available, and maintain a record of the organization's responses.
- (3) Maintain a current file of the name, address, and telephone numbers of each minority and female off-the-street applicant and minority or female referral from a union, a recruitment source, or community organization and of what action was taken with respect to each such individual. If such individual was sent to the union hiring hall for referral and was not referred back to the contractor by the union or, if referred, not employed by the contractor, this shall be documented in the file with the reason therefore, along with whatever additional actions the contractor may have taken.
- (4) Provide immediate written notification to the Director when the union or unions with which the contractor has a collective bargaining agreement has not referred to the contractor a minority person or woman sent by the contractor, or when the contractor has other information that the union referral process has impeded the contractor's efforts to meet its obligations.
- (5) Develop on-the-job training opportunities and/or participate in training programs for the area which expressly include minorities and women, including upgrading programs and apprenticeship and trainee programs relevant to the contractor's employment needs, especially those programs funded or approved by the Department of Labor. The contractor shall provide notice of these programs to the sources compiled under 3g (2) above.
- (6) Disseminate the contractor's EEO policy by providing notice of the policy to unions and training programs and requesting their cooperation in assisting the contractor in meeting its EEO obligations; by including it in any policy manual and collective bargaining agreement; by publicizing it in the company newspaper, annual report, etc.; by specific review of the policy with all management personnel and with all minority and female employees at least once a year; and by posting the company EEO policy

on bulletin boards accessible to all employees at each location where construction work is performed.

- (7) Review, at least annually, the company's EEO policy and affirmative action obligations under these specifications with all employees having any responsibility for hiring, assignment, layoff, termination or other employment decisions including specific review of these items with on-site supervisory personnel such as Superintendents, General Foremen, etc., prior to the initiation of construction work at any job site. A written record shall be made and maintained identifying the time and place of these meetings, persons attending, subject matter discussed, and disposition of the subject matter.
- (8) Disseminate the contractor's EEO policy externally by including it in any advertising in the news media, specifically including minority and female news media, and providing written notification to and discussing the contractor's EEO policy with other contractors and subcontractors with whom the contractor does or anticipates doing business.
- (9) Direct its recruitment efforts, both oral and written, to minority, female, and community organizations; to schools with minority and female students; and to minority and female recruitment and training organizations serving the contractor's recruitment area and employment needs. Not later than one month prior to the date for the acceptance of applications for apprenticeship or other training by any recruitment sources, the contractor shall send written notification to organizations such as the above, describing the opening, screening procedures, and tests to be used in the selection process.
- (10) Encourage present minority and female employees to recruit other minority persons and women and, where reasonable, provide after school, summer, and vacation employment to minority and female youth, both on the site and in other areas of a contractor's work force.
- (11) Validate all tests and other selection requirements where there is an obligation to do so under 41 CFR Part 60-3, Uniform Guidelines on Employee Selection Procedures.
- (12) Conduct, at least annually, an inventory and evaluation at least of all minority and female personnel for promotional opportunities and encourage these employees to seek or to prepare for, through appropriate training, etc., such opportunities.
- (13) Ensure that seniority practices, job classifications, work assignments, and other personnel practices do not have a discriminatory effect by continually monitoring all personnel and employment-related activities to ensure that the EEO policy and the contractor's obligations under these specifications are being carried out.
- (14) Ensure that all facilities and company activities are non-segregated except that separate or single-user toilet and necessary changing facilities shall be provided to assure privacy between the sexes.

- (15) Document and maintain a record of all solicitations of offers for subcontracts from minority and female construction contractors and suppliers, including circulation of solicitations to minority and female contractor associations and other business associations.
 - (16) Conduct a review, at least annually, of all supervisors' adherence to and performance under the contractor's EEO policies and affirmative action obligations.
- h. Contractors are encouraged to participate in voluntary associations which assist in fulfilling one or more of their affirmative action obligations 3g(1) through (16). The efforts of a contractor association, joint contractor-union, contractor-community, or other similar group of which the contractor is a member and participant, may be asserted as fulfilling any one or more of its obligations under 3g(1) through (16) of these specifications provided that the contractor actively participates in the group, makes every effort to ensure that the group has a positive impact on the employment of minorities and women in the industry, ensures that the concrete benefits of the program are reflected in the contractor's minority and female work force participation, makes a good faith effort to meet its individual goals and timetables, and can provide access to documentation which demonstrates the effectiveness of actions taken on behalf of the contractor. The obligation to comply, however, is the contractor's, and failure of such a group to fulfill an obligation shall not be a defense for the contractor's noncompliance.
- i. A single goal for minorities and a separate single goal for women have been established. The contractor, however, is required to provide equal employment opportunity and to take affirmative action for all minority groups, both male and female, and all women, both minority and non-minority. Consequently, the contractor may be in violation of the Executive Order if a particular group is employed in a substantially disparate manner (for example, even though the contractor has achieved its goals for women generally, the contractor may be in violation of the Executive Order if a specific minority group of women is underutilized).
- j. The contractor shall not use the goals and timetables of affirmative action standards to discriminate against any person because of race, color, religion, sex or national origin.
- k. The contractor shall not enter into any subcontract with any person or firm debarred from Government contracts pursuant to Executive Order 11246.
- l. The contractor shall carry out such sanctions and penalties for violation of these specifications and of the Equal Opportunity Clause, including suspension, termination, and cancellation of existing subcontracts as may be imposed or ordered pursuant to Executive Order 11246, as amended, and its implementing regulations, by the Office of Federal Contract Compliance Programs. Any contractor who fails to carry out such sanctions and penalties shall be in violation of these specifications and Executive Order 11246, as amended.

- m. The contractor, in fulfilling its obligations under these specifications, shall implement specific affirmative actions steps, at least as extensive as those standards prescribed in Paragraph 3g of these specifications, so as to achieve maximum results from its efforts to ensure equal employment opportunity. If the contractor fails to comply with the requirements of the Executive Order, the implementing regulations, or these specifications, the Director shall proceed in accordance with 41 CFR Part 60-1.8 (Show Cause Notice).
 - n. The contractor shall designate a responsible official to monitor all employment related activity to ensure that the company EEO policy is being carried out, to be required by the Government and to keep records. Records shall at least include for each employee the name, address, telephone numbers, construction trade, union affiliation, if any, employee identification number when assigned, social security number, race, sex, status (e.g., mechanic, apprentice, trainee, helper, or laborer), dates of changes in status, hours worked per week in the indicated trade, rate of pay, and locations at which the work was performed. Records shall be maintained in an easily understandable and retrievable form; however, to the degree that existing records satisfy this requirement, contractors shall not be required to maintain separate records.
 - o. Nothing herein provided shall be construed as a limitation upon the application of other laws which establish different standards of compliance or upon the application of requirements for the hiring of local or other area residents (e.g., those under the Public Works Employment Act of 1977 and the Community Development Block Grant Program).
 - p. The Director, from time to time, shall issue goals and timetables for minority and female utilization which shall be based on appropriate work force, demographic or other relevant data and which shall cover construction projects or construction contracts performed in specific geographic areas. The goals, which shall be applicable to each construction trade in a covered contractor's or subcontractor's entire work force which is working in the area covered by the goals and timetables, shall be published as notices in the Federal Register, and shall be inserted by the contracting officers and applicants, as applicable, in the Notice required by 41 CFR 60-4.2.
4. **SPECIFIC EEO REQUIREMENTS.** For a federally assisted construction contract in excess of \$10,000, the contractor/subcontractor shall:
- a. Forward the following EEO certification forms to the contract awarding authority prior to contract award: Certification of Non-segregated Facilities and Certification with Regard to the Performance of Previous Contracts or Subcontracts Subject to the Equal Opportunity Clause and the Filing of Required Reports.
 - b. Submit a notification of subcontracts awarded to the Director, Office of Federal Contract Compliance Programs, United States Department of Labor - ESA, 200 Constitutional Avenue, NW, Room C3325, Washington, D.C., 20210, within 10 working days of award of any subcontract in excess of \$10,000, listing the name, address, and telephone number of the subcontractor; employer identification number; estimated dollar amount of the subcontract; estimated starting date

and completion dates of the subcontract; and the geographical area in which the contract is to be performed.

- c. Send a notice of the contractor's commitment to equal employment opportunity to labor unions or representatives of workers prior to commencement of construction work.
 - d. Display an equal employment opportunity poster in a conspicuous place available to employees and applicants for employment.
 - e. For contracts in excess of \$10,000, bind subcontractors to the Federal Equal Employment Opportunity requirements by including the provisions of Paragraphs 1 through 3, above, in the subcontract.
 - f. Upon commencement of construction work and until the work is completed, forward the Monthly Employment Utilization Report (Form CC-257) to the contract awarding authority by the end of each work month. With the initial monthly report, the contractor/subcontractor shall attach the Contractor's List of Federal and Non-Federal Work in Bid Condition Area to the monthly report.
5. **CIVIL RIGHTS ACT OF 1964.** Under Title VI of the Civil Rights Act of 1964, no person shall, on the grounds of race, color, or national origin, be excluded from participation in, be denied the benefits of, or be subjected to discrimination under any program or activity receiving Federal financial assistance.
6. **SECTION 109 OF THE HOUSING AND COMMUNITY DEVELOPMENT ACT OF 1974.** No person in the United States on the grounds of race, color, national origin, or sex be excluded from participation in, be denied the benefits of, or be subjected to discrimination under any program or activity funded in whole or in part with funds made available under this title.
7. **THE AGE DISCRIMINATION ACT OF 1975.** No person in the United States shall, on the basis of age, be excluded from participation in, be denied the benefits of, or be subjected to discrimination under any program or activity receiving Federal financial assistance.
8. **REHABILITATION ACT OF 1973.** No otherwise qualified individual with handicaps in the United States shall, solely by reason of his or her handicap, be excluded from the participation in, be denied the benefits of, or be subjected to discrimination under any program or activity receiving Federal assistance.

EXHIBIT 4

Minority and Women-Owned Business Enterprise Plan

A. Background

The Awarding Agency is a recipient of federal housing and community development assistance through the U.S. Department of Housing and Urban Development (HUD). OMB Circular A-102 states that "It is national policy to award a fair share of contracts to small and minority business firms. Grantees shall take similar appropriate affirmative action to support of women's enterprises and are encouraged to procure goods and services from labor surplus areas." The Uniform Administrative Requirements of 24 CFR 85.36(e) require the Awarding Agency to "take all necessary affirmative steps to assure that minority firms, women's business enterprises, and labor surplus area firms are used when possible." This requirement is applicable to contracting and subcontracting opportunities funded in whole or in part with the federal housing and community development assistance.

Further, the Awarding Agency is required to submit a report to HUD pertaining to the Awarding Agency's Minority Business Enterprise (MBE) and Women's Business Enterprise (WBE) contracting and subcontracting activity generated through the expenditure of HUD funds.

B. Policy

For the purpose of this contract award, the Awarding Agency shall utilize MBE/WBE firms to the greatest extent possible, feasible and legally permissible. This MBE/WBE Plan is guided by the preceding federal regulations and all other related federal and state laws and regulations governing discrimination, equal opportunity and affirmative action pertaining to federally-funded contract and subcontract activities.

The Awarding Agency requires all bidders to abide by these provisions and to make every effort to obtain MBE/WBE participation on this project. Failure to provide required MBE/WBE information to the Awarding Agency as required or requested in this bid solicitation may result in a determination by the Awarding Agency that the bidder is not a responsible bidder.

A successful bidder does not have to be a member of a minority group. What the Awarding Agency is attempting to do is make every possible effort to ensure the participation of MBE/WBE firms on this federally-funded contracting opportunity. This does not preclude the participation of firms that are not MBE/WBE. However, the MBE and WBE performing or providing services must not act merely as a passive conduit. In the event the Awarding Body has reason to question the authenticity of ownership of an MBE/WBE, the burden of proof is on the claimant and/or contracting party to provide documentation to substantiate the ownership and management of a particular MBE or WBE.

Whenever a joint venture MBE/WBE involves a business owned by minorities or women, the contractor shall provide the Awarding Agency with a full account of the nature of the relationship, the basis for creation, the particular financial participation and administrative responsibilities of the parties. The nature of the relationship shall be in writing, and conform to pertinent laws governing the relationships. The Awarding Agency shall have the right to review and make a determination on the propriety of same.

C. Definitions

- a. Minority and women business enterprises are defined as any financial institution, business, service, contracting business which is solely owned and operated by a minority group member or women or that is more than 50% owned by minority group members or women. If the enterprise is publicly owned, the minority/women members or stockholders must have at least 51% interest and possess control over management, capital and earnings.
- b. Minority Group Member- Black, Hispanic, Asian or Pacific Islander, American Indian or Alaskan Native, and women.
 - Black: A person with origins in any of the black racial groups of Africa.
 - Hispanic: A person of Mexican, Puerto Rican, Cuban, Central or South American descent and Spanish culture. Portuguese are excluded from the Hispanic category and are classified according to their race.
 - Asian or Pacific Islander: A person having origins in the Far East, Southeast Asia, Indian subcontinent or Pacific Islands.
 - American Indian or Alaskan Native: A person with origins in original peoples of North America, and who maintain cultural identifications through tribal affiliation or community recognition.
- c. Other
 - Small Business Enterprise: A business which meets the definition of minority business enterprise or women business enterprise, and in addition, meets the small business size standards of the Small Business Administration.
 - Contractor/Subcontractor/Supplier: The individual, partnership, corporation or other legal entity entering into a contract with the City or the City's contractor to perform a portion of the work.

D. Outreach Efforts

Non MBE/WBE bidders must notify minority and women contractors, associations, minority interest groups, etc., of their intention to solicit bids for subcontracts from MBE/WBE firms. This may be accomplished in a variety of ways; however, the non-MBE/WBE bidder must demonstrate that good faith efforts were made to secure the participation of MBE/WBE firms.

E. Documentation Required from Bidders to Document Responsible MBE/WBE Outreach

As part of this contract opportunity, non MBE/WBE bidders must demonstrate that they have made the subcontracting opportunity known to at least three (3) MBE/WBE firms listed in a bona-fide listing of MBE/WBE firms. Such notification must be made at least two (2) weeks prior to bid opening via registered or certified mail. If the contractor has not achieved the participation goal, the Awarding Agency will determine whether the contractor made a good faith effort based on the outreach efforts that are documented on the MBE/WBE Tiered Compliance Plan.

1. To be considered responsible, bidders must submit the MBE/WBE Tiered Compliance Plan (included in this Bid Document/Solicitation) and all supporting documentation to:
 - Document their own MBE or WBE status, or
 - Document the award of MBE and WBE subcontracts to bona-fide firms, or

- Document the required minimum three (3) firm outreach effort and any other outreach efforts.

The good-faith effort Affidavit on the MBE/WBE Tiered Compliance Plan must be notarized.

2. Some examples of acceptable good-faith supporting documentation include:
 - Responses, proposals, bids from MBE and WBE, rejections and contractor's responses.
 - Contracts with MBE and WBE organizations, associations, related agencies, disseminating bid information.
 - Copies of registered/certified letters, etc.
 - Efforts undertaken by contractor(s) to assist MBE/WBE with obtaining plans, specification, sub bid requirements and bonding.
 - Assistance and encouragement of MBE/WBE and subcontractor participation in all areas of business environment.
 - Methods used in soliciting bids from MBE/WBE, subcontractors and suppliers by advertisements, trade publications, media, etc.
 - Contracts with MBE/WBE brokers, agents, owners, operators of equipment, etc.
 - Other efforts taken by contractor to encourage MBE/WBE participation.

F. Contract Award / Protest

Where a determination is made by Awarding Agency staff as part of the MBE/WBE Bid Evaluation that a bidder is not a MBE/WBE firm or has not made the good faith effort to ensure participation by eligible, WBE and MBE subcontractors, the bid may be deemed not responsible. A bidder whose bid is deemed not responsible may protest to the Contracting Officer of the Awarding Body in writing within 72 hours of the notification of such a determination. The Contracting Officer shall review the facts presented in the written appeal, including any supporting materials, and shall issue a determination and response on the merits of the appeal within ten (10) calendar days. The decision of the Contracting Officer shall be final.

EXHIBIT 7

Certification of Understanding and Authorization

PROJECT NAME/NUMBER _____

AWARDING AGENCY _____

COMPANY NAME _____

COMPANY ADDRESS _____

LICENSE NUMBER _____

EMPLOYER IDENTIFICATION NUMBER _____

DUNS NUMBER _____

This is to certify that the principal(s), and the authorized payroll officer listed below, have read the "Contractor's Guide to Prevailing Wage Requirements for Federally Assisted Construction" and the Federal Labor Standards Provisions (HUD-4010 form) and that both parties understand these requirements.

The following person is designated as the payroll officer for the company and is authorized to sign the Statement of Compliance that will accompany each weekly Certified Payroll Report for the project:

PAYROLL OFFICER: (Individual Responsible for Signing Statements of Compliance)

NAME _____

TITLE _____

SIGNATURE _____

DATE _____

PRINCIPAL OWNER / GENERAL PARTNER: (Listed on CSLB Personnel List)

NAME _____

TITLE _____

SIGNATURE _____

DATE _____

EXHIBIT 8

Request for Additional Classification and Rate

(Next Page)

U.S. DEPARTMENT OF HOUSING AND URBAN DEVELOPMENT REPORT OF ADDITIONAL CLASSIFICATION AND RATE		HUD FORM 423C-A <small>C.P.L.S. 1-1-81, effective 1-1-81 0113113 10j</small>				
1. PROJECT NAME AND NUMBER	2. PROJECT NAME AND NUMBER					
4. BRIEF DESCRIPTION OF PROJECT	5. CHARACTER OF CONSTRUCTION <input type="checkbox"/> Building <input type="checkbox"/> Residential <input type="checkbox"/> Heavy <input type="checkbox"/> Other (specify) <input type="checkbox"/> Highway					
6. COPY ATTACHED	7. WAGE DECISION EFFECTIVE DATE					
8. WORK CLASSIFICATION(S)	HOURLY WAGE RATES <table border="1" style="width: 100%; border-collapse: collapse;"> <thead> <tr> <th style="width: 50%;">BASIC WAGE</th> <th style="width: 50%;">FRINGE BENEFIT(S) (if any)</th> </tr> </thead> <tbody> <tr> <td style="height: 100px;"> </td> <td> </td> </tr> </tbody> </table>		BASIC WAGE	FRINGE BENEFIT(S) (if any)		
BASIC WAGE	FRINGE BENEFIT(S) (if any)					
Signature: _____	Signature: _____					
Check All That Apply: <ul style="list-style-type: none"> <input type="checkbox"/> The work to be performed by the additional classification(s) is not performed by a classification in the applicable wage decision. <input type="checkbox"/> The proposed classification is utilized in the area by the construction industry. <input type="checkbox"/> The proposed wage rate(s), including any bona fide fringe benefits, bears a reasonable relationship to the wage rates contained in the wage decision. <input type="checkbox"/> The interested parties, including the employees or their authorized representatives, agree on the classification(s) and wage rate(s). <input type="checkbox"/> Supporting documentation attached, including applicable wage decision. 						
Check One: <ul style="list-style-type: none"> <input type="checkbox"/> Approved, meets all criteria. DOL confirmation requested. <input type="checkbox"/> One or more classifications fail to meet all criteria as explained in agency referral. DOL decision requested. 						
_____ Agency Representative <small>(Typed name and signature)</small>	FOR HUD USE ONLY LR2000: Log in: Log out:					

HUD-4230A (2-03) PREVIOUS EDITION IS OBSOLETE

EXHIBIT 9

Non-Segregated Facilities Certification

PROJECT NAME _____

PROJECT NUMBER _____

BID/CONTRACT DOLLAR AMOUNT _____

COMPANY NAME _____

COMPANY ADDRESS _____

LICENSE NUMBER _____

EMPLOYER IDENTIFICATION NUMBER _____

DUNS NUMBER _____

The federally-assisted construction contractor certifies that he/she does not and will not:

1. Maintain or provide, for his/her employees, any segregated facilities at any of his/her establishments.
2. Permit his/her employees to perform their services at any location, under his/her control, where segregated facilities are maintained.

The federally assisted contractor agrees that a breach of this certification is a violation of the Equal Opportunity Clause in this contract. As used in this certification, the term segregated facilities means any waiting room, work areas, restrooms and washrooms, restaurants and other eating areas, time clocks, locker rooms and other storage or dressing areas, parking lots, drinking fountains, recreation or entertainment areas, transportation, and housing facilities provided for employees which are segregated by explicit directive or are in fact segregated on the basis of race, creed, color, or national origin, because of habit, local custom, or otherwise.

The federally-assisted contractor agrees that (except where he/she has obtained identical certifications from proposed subcontractors for specific time periods) he/she will obtain identical certifications from proposed subcontractors prior to the award of subcontracts exceeding \$10,000 which are not exempt from the provisions of the Equal Opportunity Clause, and that he/she will retain such certifications in his/her files.

NOTE: The penalty for making false statements in offers is prescribed in 18 U.S.C. 1001.

AUTHORIZED OFFICIAL NAME _____

AUTHORIZED OFFICIAL TITLE/CAPACITY _____

AUTHORIZED OFFICIAL SIGNATURE _____

DATE _____

EXHIBIT 10

Past Performance Certification

PROJECT NAME PROJECT NUMBER NUMBER OF EMPLOYEES

COMPANY NAME

COMPANY ADDRESS

LICENSE NUMBER EMPLOYER IDENTIFICATION NUMBER DUNS NUMBER

The bidder, proposed sub-contractor, hereby certifies that he/she has, has not, participated in a previous contract or subcontract subject to the Equal Opportunity Clause, as required by Executive Orders 10925, 11114, or 11246, and that he/she has, has not, filed with the Joint Reporting Committee, the Director of the Office of Federal Contract Compliance, a Federal Government contracting or administering agency, or the former President's Committee on Equal Employment Opportunity, all reports due under the applicable filing requirements.

NOTE: The penalty for making false statements in offers is prescribed in 18 U.S.C. 1001.

AUTHORIZED OFFICIAL NAME AUTHORIZED OFFICIAL TITLE/CAPACITY

AUTHORIZED OFFICIAL SIGNATURE DATE

NOTE: The above certification is required by the Equal Employment Opportunity Regulations of the Secretary of Labor (41 CFR 60-1.7(b)(1)), and must be submitted by bidders and proposed subcontractors only in connection with contracts and subcontracts which are subject to the equal opportunity clause. Contracts and subcontracts which are exempt from the equal opportunity clause are set forth in 41 CFR 60-1.5 (Generally only contracts or subcontracts of \$10,000 or under are exempt). Proposed prime contractors and subcontractors who have participated in a previous contract or subcontract subject to the Executive Orders and have not filed the required reports should note that 41 CFR 60-1.7(b)(1) prevents the award of contracts and subcontracts unless such contractor submits a report covering the delinquent period or such other period specified by the U.S. Department of the Interior or by the Director, Office of Federal Contract Compliance, U.S. Department of Labor.

SF-100 (EEO-1) must be filed by:

- (A) All private employers who are:
(1) Subject to Title VII of the Civil Rights Act of 1964 (as amended) with 100 or more employees.
(2) Subject to Title VII who has fewer than 100 employees, if the company is owned or affiliated with another company, or there is centralized ownership, control or management so that the group legally constitutes a single enterprise, and the entire enterprise employs a total of 100 or more employees.
(B) All federal contractors (private employers), who:
(1) Are not exempt as provided for by 41 CFR 60-1.5
(2) Have 50 or more employees, and
a. Are prime contractors or first-tier subcontractors, and have a contract, subcontract, or purchase order amounting to \$50,000 or more; or
b. Serve as a depository of Government funds in any amount, or
c. Is a financial institution, which is an issuing, and paying agent for U.S. Savings Bonds and Notes.

EXHIBIT 11

Notice of Equal Employment Opportunity

TO:

NAME OF LABOR UNION, WORKERS REPRESENTATIVE, ETC.

ADDRESS

PROJECT NAME

PROJECT NUMBER

BID/CONTRACT DOLLAR AMOUNT

COMPANY NAME

COMPANY ADDRESS

LICENSE NUMBER

EMPLOYER IDENTIFICATION NUMBER

DUNS NUMBER

The Undersigned currently holds a contract with _____ involving funds of the U. S. Government, or a subcontract with a prime contractor holding such contract.

You are advised that under the provisions of the above contract or subcontract, and in accordance with Executive Order 11246, the undersigned is obligated not to discriminate against any employee or applicant for employment because of race, color, religion, sex or national origin. This obligation not to discriminate in employment includes, but is not limited to the follow:

1. Hiring, placement, upgrading, transfer or demotion;
2. Recruitment, advertising or solicitation for employment;
3. Treatment during employment;
4. Rates of pay or other forms of compensation;
5. Selection for training, including apprenticeship; and
6. Layoff or termination.

This notice is furnished to you pursuant to the provisions of the above contract or subcontract and Executive Order 11246. Copies of this notice will be posted by the undersigned in conspicuous places available to employees or applicants for employment.

NOTE: The penalty for making false statements in offers is prescribed in 18 U.S.C. 1001.

AUTHORIZED OFFICIAL NAME

AUTHORIZED OFFICIAL TITLE/CAPACITY

AUTHORIZED OFFICIAL SIGNATURE

DATE

EXHIBIT 12

Minority and Women's Business Enterprise Tiered Compliance Plan

THIS PLAN MUST BE SUBMITTED WITH YOUR BID FOR THIS FEDERALLY-FUNDED CONTRACT OPPORTUNITY

PART 1

DATE _____ PROJECT NAME _____ PROJECT NUMBER _____

FIRM NAME _____ PHONE _____

BUSINESS ADDRESS _____

TYPE OF FIRM:

(Check One and Provide Information)

- Individual Name of Owner _____
- Corporation State of Incorporation: _____
- Partnership Indicate General "G", Limited "L": _____
- Name of Partners: _____
- Joint Venture Joint Venture Participants: _____

Number of year(s) firm has been in business under present ownership: _____

OWNERSHIP DEMOGRAPHICS:

(Provide the number of owners by category and the percentage of ownership interest of those individuals by category)

	Black	Hispanic	Alaskan Native/ American Indian	Asian/ Pacific Islander	White	Women
Number						
% of Assets Owned						

OWNERSHIP INFORMATION:

(List each owner of the firm that has 5 percent or more of the shares in the firm)

Name	Race	Sex	Years of Ownership	Ownership Percentage	Voting Percentage

I certify that the information provided herein is true and correct.

Federal EIN: _____

License Number: _____

DUNS Number: _____

SIGNATURE

DATE

**IF MORE THAN 50% MINORITY OR WOMEN OWNED, PROCEED TO PART 3.
IF LESS, PROCEED TO PART 2 AND PROVIDE INFORMATION ON SUBCONTRACTS AWARDED TO MBE/WBE FIRMS.**

PART 3

CONTRACTING/GOOD-FAITH EFFORT AFFIDAVIT

This Affidavit must be signed, notarized and submitted with your bid or proposal. In addition, documentation must be attached to demonstrate that a good-faith effort was made to secure MBE/WBE participation. Your good-faith effort will be evaluated in accordance with the various criteria listed below.

Please initial where indicated that you have read and complied with each requirement. Complete the requested forms and provide the requested documentation as a part of this affidavit.

Good Faith Effort Evaluation Criteria	Initial here If true and correct
1. The Bidder/Firm attended a pre-bid meeting hosted by the awarding agency to gain knowledge of the project requirements and goals.	_____
2. The Bidder/Firm advertised the availability of subcontracting or supply opportunities for MBE/WBE firms in connection with this project. If so, complete the following: Media where advertised: _____ Media contact information: _____ _____ Date(s) of advertisement: _____ Attach copies of the advertisement(s) to this form and submit with bid.	_____
3. Interested potential MBE/WBE subcontractors were provided with the project plans and specifications. Attach a list of MBE/WBE firms that received project plans and specifications. Include their address, city, state, zip code, contact person, telephone number. Provide a notation of any responses received from those firms.	_____
4. Follow-up contacts were made with potential MBE/WBE firms which expressed an interest in the project. Attach a list of MBE/WBE firms that your company followed-up with. Include their address, city, state, zip code, contact person, telephone number. Provide a notation of any responses received from those firms.	_____
5. Assistance was requested from organizations which identify potential MBE/WBE firms. Attach a list of organizations consulted to include the name of the organization, address, city, state, zip code, contact person, time and dates contracted, method contacted, and results.	_____

Good Faith Effort Evaluation Criteria

**Initial here
If true and correct**

6. Potential MBE/WBE firms were contacted and negotiation was made in good faith.

Attach a list of MBE/WBE firms that your company negotiated with. Include the name of the MBE/WBE firm, address, city, state, zip code, contact person, whether MBE or WBE, if plans or specifications were provided to the other party, and the results of your negotiations. Also attach copies of any internal documents that will evidence the same and submit with bid.

7. Potential MBE/WBE subcontractors were given technical assistance by the bidder or advised that technical assistance was available from the bidder to facilitate understanding of the contract requirements and to complete the paperwork necessary to participate in this contract.

Attach a list of MBE/WBE firms that your company provided assistance to. Include the name of the MBE/WBE firm, address, city, state, zip code, contact person, and a description of the technical assistance provided.

According to Title 18, Section 1001 of the U.S. Code, it is a felony for any person to knowingly and willingly make false or fraudulent statements to any department of the United States Government. I, the undersigned, hereby certify that all statements contained herein, are true and correct to the best of my knowledge and belief.

Under the penalty of perjury, I certify that the above information is true and correct.

SIGNATURE

DATE

TITLE

PHONE

(NOTARY SEAL)

EXHIBIT 13

County Lobbyist Certification

Los Angeles County Compliance Form – To be submitted with Bid

COUNTY LOBBYIST CODE CHAPTER 2.160

COUNTY ORDINANCE NO. 93-0031

Name of Firm: _____

Address: _____

State: _____ Zip Code: _____ Telephone Number: () _____

Acting on behalf of the above named firm, as its Authorized Official, I make the following Certification to the County of Los Angeles and the Community Development Commission, County of Los Angeles:

1) It is understood that each person/entity/firm who applies for a Community Development Commission contract, and as part of that process, shall certify that they are familiar with the requirements of the Los Angeles County Code, Chapter 2.160 (Los Angeles County Ordinance 93-0031) and;

2) That all persons/entities/firms acting on behalf of the above named firm have and will comply with the County Code, and;

3) That any person/entity/firm who seeks a contract with the Community Development Commission shall be disqualified therefrom and denied the contract and, shall be liable in civil action, if any lobbyist, lobbying firm, lobbyist employer or any other person or entity acting on behalf of the named firm fails to comply with the provisions of the County Code.

This certification is a material representation of fact upon which reliance was placed when this transaction was made or entered into. Submission of this certification is a prerequisite for making or entering into contract with the Los Angeles County and the Community Development Commission, County of Los Angeles.

Authorized Official:

(Contractor/Subcontractor)

By: _____
(Signature)

(Date)

(Title)

EXHIBIT 14

Fringe Benefit Statement

(Next Page)

Fringe Benefit Payment Certification

PROJECT NAME _____

AWARDING AGENCY / CONTRACTOR _____

PROJECT LOCATION _____

COMPANY NAME _____

COMPANY ADDRESS _____

LICENSE NUMBER _____

EMPLOYER IDENTIFICATION NUMBER _____

DUNS NUMBER _____

WORK CLASSIFICATION	HOURLY FRINGE BENEFITS PROVIDED	NAME, ADDRESS, AND TELEPHONE NUMBER OF THE APPROVED PLAN, FUND, OR PROGRAM
	Health & Welfare	\$
	Pension	\$
	Vacation	\$
	Apprenticeship/Training	\$
	Other (explain)	\$
	TOTAL HOURLY FRINGE	\$
	Health & Welfare	\$
	Pension	\$
	Vacation	\$
	Apprenticeship/Training	\$
	Other (explain)	\$
	TOTAL HOURLY FRINGE	\$
	Health & Welfare	\$
	Pension	\$
	Vacation	\$
	Apprenticeship/Training	\$
	Other (explain)	\$
	TOTAL HOURLY FRINGE	\$
	Pension	\$
	Vacation	\$
	Apprenticeship/Training	\$
	Other (explain)	\$
TOTAL HOURLY FRINGE	\$	

I Certify under penalty of perjury that:

- I make payments to approved fringe benefit plans, funds, or programs as listed above.
- OR-
- I DO NOT make payments to approved fringe benefit plans, funds, or programs. Benefits are added to hourly rates and paid each week to the employees.

AUTHORIZED OFFICIAL NAME _____

AUTHORIZED OFFICIAL TITLE/CAPACITY _____

AUTHORIZED OFFICIAL SIGNATURE _____

DATE _____

EXHIBIT 15

Payroll Report & Statement of Compliance

(Next Page)

EXHIBIT 16

Agency Report of Contract Award

(Next Page)

AGENCY REPORT OF CONSTRUCTION CONTRACT AWARD

(03/21/17)

TO: Contract Compliance Officer, Grants Management Unit
Community Development Commission, County of Los Angeles

Date: _____

FROM: _____ **Local Contracting Agency Name:** _____

Project Name: _____ **Project Number:** _____

A formal bid opening, or informal solicitation for this construction contract was held on: **Date:** _____

A Contract Subcontract was awarded to the contractor identified below on: **Date:** _____

The contract amount for the scope of work to be performed by this Contractor, as detailed below, is: **Amount:** _____

This is or is not a *Section 3 qualified construction contract* _____

A *Section 3* Pre-Bid Meeting was held on: **Date:** _____

A copy of the completed *Section 3 Bid Evaluation* form was provided to the CDC on: **Date:** _____

The Contractor's Eligibility was verified prior to the contract with search results from:

California Contractors State Licensing Board (CSLB) website (<http://www.cslb.ca.gov>) on: **Date:** _____

California Department of Industrial Relations (DIR) website (<https://efiling.dir.ca.gov/PWCR/Search>) on: **Date:** _____

California Department of Industrial Relations (DIR) website (<https://www.dir.ca.gov/dlse/debar>) on: **Date:** _____

Federal List of Parties Excluded from federal contract award website (<https://www.sam.gov>) on: **Date:** _____

A *Notice of Contract Award* letter was sent to the U.S. Dept. of Labor, OFCCP (contracts \$10,000 or more) on: **Date:** _____

► Identify the detailed scope of work FOR THIS CONTRACTOR

Estimated Start Date: _____

Estimated Completion Date: _____

► Identify the work classifications to be USED BY THIS CONTRACTOR at the construction site

Estimated Workforce size: _____

- | | | | | |
|--|---|-------------|--|---|
| <input type="checkbox"/> Asbestos Worker | <input type="checkbox"/> Equipment Operator | Group _____ | <input type="checkbox"/> Lather | <input type="checkbox"/> Roofer |
| <input type="checkbox"/> Bricklayer | <input type="checkbox"/> Glazier | | <input type="checkbox"/> Marble setter | <input type="checkbox"/> Sheet metal worker |
| <input type="checkbox"/> Carpenter | <input type="checkbox"/> Ironworker | | <input type="checkbox"/> Painter | <input type="checkbox"/> Terrazzo Worker |
| <input type="checkbox"/> Cement Mason | <input type="checkbox"/> Laborer | Group _____ | <input type="checkbox"/> Plasterer | <input type="checkbox"/> Tile layer |
| <input type="checkbox"/> Electrician | <input type="checkbox"/> Labor/Striper | Group _____ | <input type="checkbox"/> Plumber | _____ (other) |

The Contractor(s) acknowledge, by signature below, that: "This construction project is funded in whole or in part with Federal funds."

A copy of the *Federal Labor Standards Provisions* (HUD-4010 form), is attached to the contractor's copy of this form.

A copy of the assigned *Federal Wage Decision* identified below, is attached to the contractor's copy of this form.

Federal Wage Decision Number: CA _____ Mod. _____, DATED _____ (<http://www.wdol.gov>).

The Contractor(s) further acknowledge that federal prevailing wage and fringe benefit rates must be paid to all workers each week.

Print Company Name above – Prime Contractor Subcontractor

Print Company Name above – Subcontractor Lower-tier

Employer Identification Number: _____

Employer Identification Number: _____

Contractor License Number: _____

Contractor License Number: _____

Authorized Signature of Company Representative

Authorized Signature of Company Representative

- | | | |
|--|---|---|
| <input type="checkbox"/> Black American | <input type="checkbox"/> Women Owned Business | <input type="checkbox"/> Native American |
| <input type="checkbox"/> White American | <input type="checkbox"/> Minority Owned Business | <input type="checkbox"/> Hasidic Jews |
| <input type="checkbox"/> Hispanic American | <input type="checkbox"/> Section 3 Qualified Business | <input type="checkbox"/> Asian/Pacific American |

- | | | |
|--|---|---|
| <input type="checkbox"/> Black American | <input type="checkbox"/> Women Owned Business | <input type="checkbox"/> Native American |
| <input type="checkbox"/> White American | <input type="checkbox"/> Minority Owned Business | <input type="checkbox"/> Hasidic Jews |
| <input type="checkbox"/> Hispanic American | <input type="checkbox"/> Section 3 Qualified Business | <input type="checkbox"/> Asian/Pacific American |

EXHIBIT 17

Federal Wage Decision

(Next Page)

General Decision Number: CA180033 02/23/2018 CA33

Superseded General Decision Number: CA20170033

State: California

Construction Types: Building, Heavy (Heavy and Dredging) and Highway

County: Los Angeles County in California.

BUILDING CONSTRUCTION PROJECTS; DREDGING PROJECTS (does not include hopper dredge work); HEAVY CONSTRUCTION PROJECTS (does not include water well drilling); HIGHWAY CONSTRUCTION PROJECTS

Note: Under Executive Order (EO) 13658, an hourly minimum wage of \$10.35 for calendar year 2018 applies to all contracts subject to the Davis-Bacon Act for which the contract is awarded (and any solicitation was issued) on or after January 1, 2015. If this contract is covered by the EO, the contractor must pay all workers in any classification listed on this wage determination at least \$10.35 per hour (or the applicable wage rate listed on this wage determination, if it is higher) for all hours spent performing on the contract in calendar year 2018. The EO minimum wage rate will be adjusted annually. Please note that this EO applies to the above-mentioned types of contracts entered into by the federal government that are subject to the Davis-Bacon Act itself, but it does not apply to contracts subject only to the Davis-Bacon Related Acts, including those set forth at 29 CFR 5.1(a)(2)-(60). Additional information on contractor requirements and worker protections under the EO is available at www.dol.gov/whd/govcontracts.

Modification Number	Publication Date
0	01/05/2018
1	01/12/2018
2	01/19/2018
3	02/09/2018
4	02/23/2018

ASBE0005-002 07/03/2017

	Rates	Fringes
Asbestos Workers/Insulator (Includes the application of all insulating materials, protective coverings, coatings, and finishes to all types of mechanical systems).....	\$ 39.72	20.81
Fire Stop Technician (Application of Firestopping Materials for wall openings and penetrations in walls, floors, ceilings and curtain walls).....	\$ 26.96	17.81

ASBE0005-004 07/03/2017

	Rates	Fringes
Asbestos Removal worker/hazardous material handler (Includes preparation, wetting, stripping, removal, scrapping, vacuuming, bagging and disposing of all insulation materials from mechanical systems, whether they contain asbestos or not)....	\$ 19.26	11.27

BOIL0092-003 10/01/2012

	Rates	Fringes
BOILERMAKER.....	\$ 41.17	28.27

* BRCA0004-007 05/01/2017

	Rates	Fringes
BRICKLAYER; MARBLE SETTER.....	\$ 39.91	15.45

*The wage scale for prevailing wage projects performed in Blythe, China lake, Death Valley, Fort Irwin, Twenty-Nine Palms, Needles and 1-15 corridor (Barstow to the Nevada State Line) will be Three Dollars (\$3.00) above the standard San Bernardino/Riverside County hourly wage rate

BRCA0018-004 07/01/2017

	Rates	Fringes
MARBLE FINISHER.....	\$ 30.93	12.95
TILE FINISHER.....	\$ 25.98	11.23
TILE LAYER.....	\$ 37.76	16.37

BRCA0018-010 09/01/2017

	Rates	Fringes
TERRAZZO FINISHER.....	\$ 29.75	12.91
TERRAZZO WORKER/SETTER.....	\$ 36.75	13.82

CARP0409-001 07/01/2016

	Rates	Fringes
CARPENTER (1) Carpenter, Cabinet Installer, Insulation Installer, Hardwood Floor		

Worker and acoustical installer.....	\$ 39.83	15.50
(2) Millwright.....	\$ 40.90	15.50
(3) Piledrivermen/Derrick Bargeman, Bridge or Dock Carpenter, Heavy Framer, Rock Bargeman or Scowman, Rockslinger, Shingler (Commercial).....	\$ 40.53	15.50
(4) Pneumatic Nailer, Power Stapler.....	\$ 40.09	15.50
(5) Sawfiler.....	\$ 39.83	15.50
(6) Scaffold Builder.....	\$ 31.60	15.50
(7) Table Power Saw Operator.....	\$ 40.93	15.50

FOOTNOTE: Work of forming in the construction of open cut sewers or storm drains, on operations in which horizontal lagging is used in conjunction with steel H-Beams driven or placed in pre- drilled holes, for that portion of a lagged trench against which concrete is poured, namely, as a substitute for back forms (which work is performed by piledrivers): \$0.13 per hour additional.

 CARP0409-002 07/01/2016

	Rates	Fringes
Diver		
(1) Wet.....	\$ 712.48	17.03
(2) Standby.....	\$ 356.24	17.03
(3) Tender.....	\$ 348.24	17.03
(4) Assistant Tender.....	\$ 324.24	17.03

Amounts in "Rates" column are per day

 CARP0409-005 07/01/2015

	Rates	Fringes
Drywall		
DRYWALL INSTALLER/LATHER....	\$ 40.40	15.03
STOCKER/SCRAPPER.....	\$ 10.00	7.17

 CARP0409-008 08/01/2010

	Rates	Fringes
Modular Furniture Installer.....	\$ 17.00	7.41

 * ELEC0011-004 01/29/2018

	Rates	Fringes
ELECTRICIAN (INSIDE ELECTRICAL WORK)		
Journeyman Electrician.....	\$ 43.35	3%+27.87

ELECTRICIAN (INTELLIGENT
 TRANSPORTATION SYSTEMS Street
 Lighting, Traffic Signals,
 CCTV, and Underground Systems)

Journeyman Transportation		
Electrician.....	\$ 43.40	3%+27.82
Technician.....	\$ 32.55	3%+27.82

FOOT NOTE:

CABLE SPLICER & INSTRUMENT PERSON: Recieve 5% additional per hour above Journeyman Electrician basic hourly rate.
 TUNNEL WORK: 10% additional per hour.

SCOPE OF WORK - TRANSPORTATION SYSTEMS

ELECTRICIAN:

Installation of street lights and traffic signals, including electrical circuitry, programmable controllers, pedestal-mounted electrical meter enclosures and laying of pre-assembled multi-conductor cable in ducts, layout of electrical systems and communication installation, including proper position of trench depths and radius at duct banks, location for man holes, pull boxes, street lights and traffic signals. Installation of underground ducts for electrical, telephone, cable television and communication systems. Pulling, termination and splicing of traffic signal and street lighting conductors and electrical systems including interconnect, detector loop, fiber optic cable and video/cable.

TECHNICIAN:

Distribution of material at job site, manual excavation and backfill, installation of system conduits and raceways for electrical, telephone, cable television and communication systems. Pulling, terminating and splicing of traffic signal and street lighting conductors and electrical systems including interconnect, detector loop, fiber optic cable and video/data.

 * ELEC0011-005 01/01/2018

COMMUNICATIONS & SYSTEMS WORK (excludes any work on Intelligent Transportation Systems or CCTV highway systems)

	Rates	Fringes
Communications System		
Installer.....	\$ 33.64	3%+14.33
Technician.....	\$ 32.18	3%+27.32

SCOPE OF WORK The work covered shall include the installation, testing, service and maintenance, of the following systems that utilize the transmission and/or transference of voice, sound, vision and digital for commercial, education, security and entertainment purposes

for TV monitoring and surveillance, background foreground music, intercom and telephone interconnect, inventory control systems, microwave transmission, multi-media, multiplex, nurse call system, radio page, school intercom and sound, burglar alarms and low voltage master clock systems.

A. Communication systems that transmit or receive information and/or control systems that are intrinsic to the above listed systems SCADA (Supervisory control/data acquisition PCM (Pulse code modulation) Inventory control systems Digital data systems Broadband & baseband and carriers Point of sale systems VSAT data systems Data communication systems RF and remote control systems Fiber optic data systems

B. Sound and Voice Transmission/Transference Systems Background-Foreground Music Intercom and Telephone Interconnect Systems Sound and Musical Entertainment Systems Nurse Call Systems Radio Page Systems School Intercom and Sound Systems Burglar Alarm Systems Low-Voltage Master Clock Systems Multi-Media/Multiplex Systems Telephone Systems RF Systems and Antennas and Wave Guide

C. *Fire Alarm Systems-installation, wire pulling and testing.

D. Television and Video Systems Television Monitoring and Surveillance Systems Video Security Systems Video Entertainment Systems Video Educational Systems CATV and CCTV

E. Security Systems, Perimeter Security Systems, Vibration Sensor Systems Sonar/Infrared Monitoring Equipment, Access Control Systems, Card Access Systems

*Fire Alarm Systems

1. Fire Alarms-In Raceways: Wire and cable pulling in raceways performed at the current electrician wage rate and fringe benefits.
2. Fire Alarms-Open Wire Systems: installed by the Technician.

 ELEC1245-001 06/01/2017

	Rates	Fringes
LINE CONSTRUCTION		
(1) Lineman; Cable splicer..\$	55.49	16.62
(2) Equipment specialist (operates crawler tractors, commercial motor vehicles, backhoes, trenchers, cranes (50 tons and below), overhead & underground distribution		

line equipment).....	\$ 44.32	3%+17.65
(3) Groundman.....	\$ 33.89	3%+17.65
(4) Powderman.....	\$ 49.55	3%+17.65

HOLIDAYS: New Year's Day, M.L. King Day, Memorial Day, Independence Day, Labor Day, Veterans Day, Thanksgiving Day and day after Thanksgiving, Christmas Day

ELEV0018-001 01/01/2018

	Rates	Fringes
ELEVATOR MECHANIC.....	\$ 53.85	32.645

FOOTNOTE:

PAID VACATION: Employer contributes 8% of regular hourly rate as vacation pay credit for employees with more than 5 years of service, and 6% for 6 months to 5 years of service.
PAID HOLIDAYS: New Years Day, Memorial Day, Independence Day, Labor Day, Veterans Day, Thanksgiving Day, Friday after Thanksgiving, and Christmas Day.

ENGI0012-003 07/01/2017

	Rates	Fringes
OPERATOR: Power Equipment (All Other Work)		
GROUP 1.....	\$ 44.00	24.25
GROUP 2.....	\$ 44.78	24.25
GROUP 3.....	\$ 45.07	24.25
GROUP 4.....	\$ 46.56	24.25
GROUP 5.....	\$ 47.66	24.25
GROUP 6.....	\$ 46.78	24.25
GROUP 8.....	\$ 46.89	24.25
GROUP 9.....	\$ 47.99	24.25
GROUP 10.....	\$ 48.01	24.25
GROUP 11.....	\$ 48.11	24.25
GROUP 12.....	\$ 47.18	24.25
GROUP 13.....	\$ 47.28	24.25
GROUP 14.....	\$ 47.31	24.25
GROUP 15.....	\$ 47.39	24.25
GROUP 16.....	\$ 47.51	24.25
GROUP 17.....	\$ 47.68	24.25
GROUP 18.....	\$ 47.78	24.25
GROUP 19.....	\$ 47.89	24.25
GROUP 20.....	\$ 48.01	24.25
GROUP 21.....	\$ 48.18	24.25
GROUP 22.....	\$ 48.28	24.25
GROUP 23.....	\$ 48.39	24.25
GROUP 24.....	\$ 48.51	24.25
GROUP 25.....	\$ 48.68	24.25
OPERATOR: Power Equipment (Cranes, Piledriving & Hoisting)		
GROUP 1.....	\$ 45.35	24.25

GROUP 2.....	\$ 46.13	24.25
GROUP 3.....	\$ 46.42	24.25
GROUP 4.....	\$ 46.56	24.25
GROUP 5.....	\$ 46.78	24.25
GROUP 6.....	\$ 46.89	24.25
GROUP 7.....	\$ 47.01	24.25
GROUP 8.....	\$ 47.18	24.25
GROUP 9.....	\$ 47.35	24.25
GROUP 10.....	\$ 48.35	24.25
GROUP 11.....	\$ 49.35	24.25
GROUP 12.....	\$ 50.35	24.25
GROUP 13.....	\$ 51.35	24.25
OPERATOR: Power Equipment		
(Tunnel Work)		
GROUP 1.....	\$ 41.80	23.35
GROUP 2.....	\$ 42.58	23.35
GROUP 3.....	\$ 42.87	23.35
GROUP 4.....	\$ 43.01	23.35
GROUP 5.....	\$ 43.23	23.35
GROUP 6.....	\$ 43.34	23.35
GROUP 7.....	\$ 43.46	23.35

PREMIUM PAY:

\$3.75 per hour shall be paid on all Power Equipment Operator work on the following Military Bases: China Lake Naval Reserve, Vandenberg AFB, Point Arguello, Seely Naval Base, Fort Irwin, Nebo Annex Marine Base, Marine Corp Logistics Base Yermo, Edwards AFB, 29 Palms Marine Base and Camp Pendleton

Workers required to suit up and work in a hazardous material environment: \$2.00 per hour additional. Combination mixer and compressor operator on gunite work shall be classified as a concrete mobile mixer operator.

SEE ZONE DEFINITIONS AFTER CLASSIFICATIONS

POWER EQUIPMENT OPERATORS CLASSIFICATIONS

GROUP 1: Bargeman; Brakeman; Compressor operator; Ditch Witch, with seat or similar type equipment; Elevator operator-inside; Engineer Oiler; Forklift operator (includes loed, lull or similar types under 5 tons; Generator operator; Generator, pump or compressor plant operator; Pump operator; Signalman; Switchman

GROUP 2: Asphalt-rubber plant operator (nurse tank operator); Concrete mixer operator-skip type; Conveyor operator; Fireman; Forklift operator (includes loed, lull or similar types over 5 tons; Hydrostatic pump operator; oiler crusher (asphalt or concrete plant); Petromat laydown machine; PJU side dum jack; Screening and conveyor machine operator (or similar types); Skiploader (wheel type up to 3/4 yd. without attachment); Tar pot fireman; Temporary heating plant operator; Trenching machine oiler

GROUP 3: Asphalt-rubber blend operator; Bobcat or similar type (Skid steer); Equipment greaser (rack); Ford Ferguson

(with dragtype attachments); Helicopter radioman (ground);
Stationary pipe wrapping and cleaning machine operator

GROUP 4: Asphalt plant fireman; Backhoe operator (mini-max or similar type); Boring machine operator; Boxman or mixerman (asphalt or concrete); Chip spreading machine operator; Concrete cleaning decontamination machine operator; Concrete Pump Operator (small portable); Drilling machine operator, small auger types (Texoma super economatic or similar types - Hughes 100 or 200 or similar types - drilling depth of 30' maximum); Equipment greaser (grease truck); Guard rail post driver operator; Highline cableway signalman; Hydra-hammer-aero stomper; Micro Tunneling (above ground tunnel); Power concrete curing machine operator; Power concrete saw operator; Power-driven jumbo form setter operator; Power sweeper operator; Rock Wheel Saw/Trencher; Roller operator (compacting); Screed operator (asphalt or concrete); Trenching machine operator (up to 6 ft.); Vacuum or much truck

GROUP 5: Equipment Greaser (Grease Truck/Multi Shift).

GROUP 6: Articulating material hauler; Asphalt plant engineer; Batch plant operator; Bit sharpener; Concrete joint machine operator (canal and similar type); Concrete planer operator; Dandy digger; Deck engine operator; Derrickman (oilfield type); Drilling machine operator, bucket or auger types (Calweld 100 bucket or similar types - Watson 1000 auger or similar types - Texoma 330, 500 or 600 auger or similar types - drilling depth of 45' maximum); Drilling machine operator; Hydrographic seeder machine operator (straw, pulp or seed), Jackson track maintainer, or similar type; Kalamazoo Switch tamper, or similar type; Machine tool operator; Maginnis internal full slab vibrator, Mechanical berm, curb or gutter (concrete or asphalt); Mechanical finisher operator (concrete, Clary-Johnson-Bidwell or similar); Micro tunnel system (below ground); Pavement breaker operator (truck mounted); Road oil mixing machine operator; Roller operator (asphalt or finish), rubber-tired earth moving equipment (single engine, up to and including 25 yds. struck); Self-propelled tar pipelining machine operator; Skiploader operator (crawler and wheel type, over 3/4 yd. and up to and including 1-1/2 yds.); Slip form pump operator (power driven hydraulic lifting device for concrete forms); Tractor operator-bulldozer, tamper-scraper (single engine, up to 100 h.p. flywheel and similar types, up to and including D-5 and similar types); Tugger hoist operator (1 drum); Ultra high pressure waterjet cutting tool system operator; Vacuum blasting machine operator

GROUP 8: Asphalt or concrete spreading operator (tamping or finishing); Asphalt paving machine operator (Barber Greene or similar type); Asphalt-rubber distribution operator; Backhoe operator (up to and including 3/4 yd.), small ford, Case or similar; Cast-in-place pipe laying machine operator; Combination mixer and compressor operator (gunite work); Compactor operator (self-propelled); Concrete mixer

operator (paving); Crushing plant operator; Drill Doctor; Drilling machine operator, Bucket or auger types (Calweld 150 bucket or similar types - Watson 1500, 2000 2500 auger or similar types - Texoma 700, 800 auger or similar types - drilling depth of 60' maximum); Elevating grader operator; Grade checker; Gradall operator; Grouting machine operator; Heavy-duty repairman; Heavy equipment robotics operator; Kalamazoo balliste regulator or similar type; Kolman belt loader and similar type; Le Tourneau blob compactor or similar type; Loader operator (Athey, Euclid, Sierra and similar types); Mobark Chipper or similar; Ozzie padder or similar types; P.C. slot saw; Pneumatic concrete placing machine operator (Hackley-Presswell or similar type); Pumpcrete gun operator; Rock Drill or similar types; Rotary drill operator (excluding caisson type); Rubber-tired earth-moving equipment operator (single engine, caterpillar, Euclid, Athey Wagon and similar types with any and all attachments over 25 yds. up to and including 50 cu. yds. struck); Rubber-tired earth-moving equipment operator (multiple engine up to and including 25 yds. struck); Rubber-tired scraper operator (self-loading paddle wheel type-John Deere, 1040 and similar single unit); Self-propelled curb and gutter machine operator; Shuttle buggy; Skiploader operator (crawler and wheel type over 1-1/2 yds. up to and including 6-1/2 yds.); Soil remediation plant operator; Surface heaters and planer operator; Tractor compressor drill combination operator; Tractor operator (any type larger than D-5 - 100 flywheel h.p. and over, or similar-bulldozer, tamper, scraper and push tractor single engine); Tractor operator (boom attachments), Traveling pipe wrapping, cleaning and bending machine operator; Trenching machine operator (over 6 ft. depth capacity, manufacturer's rating); trenching Machine with Road Miner attachment (over 6 ft depth capacity); Ultra high pressure waterjet cutting tool system mechanic; Water pull (compaction) operator

GROUP 9: Heavy Duty Repairman

GROUP 10: Drilling machine operator, Bucket or auger types (Calweld 200 B bucket or similar types-Watson 3000 or 5000 auger or similar types-Texoma 900 auger or similar types-drilling depth of 105' maximum); Dual drum mixer, dynamic compactor LDC350 (or similar types); Monorail locomotive operator (diesel, gas or electric); Motor patrol-blade operator (single engine); Multiple engine tractor operator (Euclid and similar type-except Quad 9 cat.); Rubber-tired earth-moving equipment operator (single engine, over 50 yds. struck); Pneumatic pipe ramming tool and similar types; Prestressed wrapping machine operator; Rubber-tired earth-moving equipment operator (single engine, over 50 yds. struck); Rubber tired earth moving equipment operator (multiple engine, Euclid, caterpillar and similar over 25 yds. and up to 50 yds. struck), Tower crane repairman; Tractor loader operator (crawler and wheel type over 6-1/2 yds.); Woods mixer operator (and similar Pugmill equipment)

GROUP 11: Heavy Duty Repairman - Welder Combination, Welder - Certified.

GROUP 12: Auto grader operator; Automatic slip form operator; Drilling machine operator, bucket or auger types (Calweld, auger 200 CA or similar types - Watson, auger 6000 or similar types - Hughes Super Duty, auger 200 or similar types - drilling depth of 175' maximum); Hoe ram or similar with compressor; Mass excavator operator less than 750 cu. yards; Mechanical finishing machine operator; Mobile form traveler operator; Motor patrol operator (multi-engine); Pipe mobile machine operator; Rubber-tired earth-moving equipment operator (multiple engine, Euclid, Caterpillar and similar type, over 50 cu. yds. struck); Rubber-tired self-loading scraper operator (paddle-wheel-auger type self-loading - two (2) or more units)

GROUP 13: Rubber-tired earth-moving equipment operator operating equipment with push-pull system (single engine, up to and including 25 yds. struck)

GROUP 14: Canal liner operator; Canal trimmer operator; Remote-control earth-moving equipment operator (operating a second piece of equipment: \$1.00 per hour additional); Wheel excavator operator (over 750 cu. yds.)

GROUP 15: Rubber-tired earth-moving equipment operator, operating equipment with push-pull system (single engine, Caterpillar, Euclid, Athey Wagon and similar types with any and all attachments over 25 yds. and up to and including 50 yds. struck); Rubber-tired earth-moving equipment operator, operating equipment with push-pull system (multiple engine-up to and including 25 yds. struck)

GROUP 16: Rubber-tired earth-moving equipment operator, operating equipment with push-pull system (single engine, over 50 yds. struck); Rubber-tired earth-moving equipment operator, operating equipment with push-pull system (multiple engine, Euclid, Caterpillar and similar, over 25 yds. and up to 50 yds. struck)

GROUP 17: Rubber-tired earth-moving equipment operator, operating equipment with push-pull system (multiple engine, Euclid, Caterpillar and similar, over 50 cu. yds. struck); Tandem tractor operator (operating crawler type tractors in tandem - Quad 9 and similar type)

GROUP 18: Rubber-tired earth-moving equipment operator, operating in tandem (scrapers, belly dumps and similar types in any combination, excluding compaction units - single engine, up to and including 25 yds. struck)

GROUP 19: Rotex concrete belt operator (or similar types); Rubber-tired earth-moving equipment operator, operating in tandem (scrapers, belly dumps and similar types in any combination, excluding compaction units - single engine, Caterpillar, Euclid, Athey Wagon and similar types with any and all attachments over 25 yds. and up to and including 50

cu. yds. struck); Rubber-tired earth-moving equipment operator, operating in tandem (scrapers, belly dumps and similar types in any combination, excluding compaction units - multiple engine, up to and including 25 yds. struck)

GROUP 20: Rubber-tired earth-moving equipment operator, operating in tandem (scrapers, belly dumps and similar types in any combination, excluding compaction units - single engine, over 50 yds. struck); Rubber-tired earth-moving equipment operator, operating in tandem (scrapers, belly dumps, and similar types in any combination, excluding compaction units - multiple engine, Euclid, Caterpillar and similar, over 25 yds. and up to 50 yds. struck)

GROUP 21: Rubber-tired earth-moving equipment operator, operating in tandem (scrapers, belly dumps and similar types in any combination, excluding compaction units - multiple engine, Euclid, Caterpillar and similar type, over 50 cu. yds. struck)

GROUP 22: Rubber-tired earth-moving equipment operator, operating equipment with the tandem push-pull system (single engine, up to and including 25 yds. struck)

GROUP 23: Rubber-tired earth-moving equipment operator, operating equipment with the tandem push-pull system (single engine, Caterpillar, Euclid, Athey Wagon and similar types with any and all attachments over 25 yds. and up to and including 50 yds. struck); Rubber-tired earth-moving equipment operator, operating with the tandem push-pull system (multiple engine, up to and including 25 yds. struck)

GROUP 24: Rubber-tired earth-moving equipment operator, operating equipment with the tandem push-pull system (single engine, over 50 yds. struck); Rubber-tired earth-moving equipment operator, operating equipment with the tandem push-pull system (multiple engine, Euclid, Caterpillar and similar, over 25 yds. and up to 50 yds. struck)

GROUP 25: Concrete pump operator-truck mounted; Rubber-tired earth-moving equipment operator, operating equipment with the tandem push-pull system (multiple engine, Euclid, Caterpillar and similar type, over 50 cu. yds. struck)

CRANES, PILEDIVING AND HOISTING EQUIPMENT CLASSIFICATIONS

GROUP 1: Engineer oiler; Fork lift operator (includes loed, lull or similar types)

GROUP 2: Truck crane oiler

GROUP 3: A-frame or winch truck operator; Ross carrier operator (jobsite)

GROUP 4: Bridge-type unloader and turntable operator;

Helicopter hoist operator

GROUP 5: Hydraulic boom truck; Stinger crane (Austin-Western or similar type); Tugger hoist operator (1 drum)

GROUP 6: Bridge crane operator; Cretor crane operator; Hoist operator (Chicago boom and similar type); Lift mobile operator; Lift slab machine operator (Vagtborg and similar types); Material hoist and/or manlift operator; Polar gantry crane operator; Self Climbing scaffold (or similar type); Shovel, backhoe, dragline, clamshell operator (over 3/4 yd. and up to 5 cu. yds. mrc); Tugger hoist operator

GROUP 7: Pedestal crane operator; Shovel, backhoe, dragline, clamshell operator (over 5 cu. yds. mrc); Tower crane repair; Tugger hoist operator (3 drum)

GROUP 8: Crane operator (up to and including 25 ton capacity); Crawler transporter operator; Derrick barge operator (up to and including 25 ton capacity); Hoist operator, stiff legs, Guy derrick or similar type (up to and including 25 ton capacity); Shovel, backhoe, dragline, clamshell operator (over 7 cu. yds., M.R.C.)

GROUP 9: Crane operator (over 25 tons and up to and including 50 tons mrc); Derrick barge operator (over 25 tons up to and including 50 tons mrc); Highline cableway operator; Hoist operator, stiff legs, Guy derrick or similar type (over 25 tons up to and including 50 tons mrc); K-crane operator; Polar crane operator; Self erecting tower crane operator maximum lifting capacity ten tons

GROUP 10: Crane operator (over 50 tons and up to and including 100 tons mrc); Derrick barge operator (over 50 tons up to and including 100 tons mrc); Hoist operator, stiff legs, Guy derrick or similar type (over 50 tons up to and including 100 tons mrc), Mobile tower crane operator (over 50 tons, up to and including 100 tons M.R.C.); Tower crane operator and tower gantry

GROUP 11: Crane operator (over 100 tons and up to and including 200 tons mrc); Derrick barge operator (over 100 tons up to and including 200 tons mrc); Hoist operator, stiff legs, Guy derrick or similar type (over 100 tons up to and including 200 tons mrc); Mobile tower crane operator (over 100 tons up to and including 200 tons mrc)

GROUP 12: Crane operator (over 200 tons up to and including 300 tons mrc); Derrick barge operator (over 200 tons up to and including 300 tons mrc); Hoist operator, stiff legs, Guy derrick or similar type (over 200 tons, up to and including 300 tons mrc); Mobile tower crane operator (over 200 tons, up to and including 300 tons mrc)

GROUP 13: Crane operator (over 300 tons); Derrick barge operator (over 300 tons); Helicopter pilot; Hoist operator, stiff legs, Guy derrick or similar type (over 300 tons); Mobile tower crane operator (over 300 tons)

TUNNEL CLASSIFICATIONS

GROUP 1: Skiploader (wheel type up to 3/4 yd. without attachment)

GROUP 2: Power-driven jumbo form setter operator

GROUP 3: Dinkey locomotive or motorperson (up to and including 10 tons)

GROUP 4: Bit sharpener; Equipment greaser (grease truck); Slip form pump operator (power-driven hydraulic lifting device for concrete forms); Tugger hoist operator (1 drum); Tunnel locomotive operator (over 10 and up to and including 30 tons)

GROUP 5: Backhoe operator (up to and including 3/4 yd.); Small Ford, Case or similar; Drill doctor; Grouting machine operator; Heading shield operator; Heavy-duty repairperson; Loader operator (Athey, Euclid, Sierra and similar types); Mucking machine operator (1/4 yd., rubber-tired, rail or track type); Pneumatic concrete placing machine operator (Hackley-Presswell or similar type); Pneumatic heading shield (tunnel); Pumpcrete gun operator; Tractor compressor drill combination operator; Tugger hoist operator (2 drum); Tunnel locomotive operator (over 30 tons)

GROUP 6: Heavy Duty Repairman

GROUP 7: Tunnel mole boring machine operator

ENGINEERS ZONES

\$1.00 additional per hour for all of IMPERIAL County and the portions of KERN, RIVERSIDE & SAN BERNARDINO Counties as defined below:

That area within the following Boundary: Begin in San Bernardino County, approximately 3 miles NE of the intersection of I-15 and the California State line at that point which is the NW corner of Section 1, T17N,m R14E, San Bernardino Meridian. Continue W in a straight line to that point which is the SW corner of the northwest quarter of Section 6, T27S, R42E, Mt. Diablo Meridian. Continue North to the intersection with the Inyo County Boundary at that point which is the NE corner of the western half of the northern quarter of Section 6, T25S, R42E, MDM. Continue W along the Inyo and San Bernardino County boundary until the intersection with Kern County, as that point which is the SE corner of Section 34, T24S, R40E, MDM. Continue W along the Inyo and Kern County boundary until the intersection with Tulare County, at that point which is the SW corner of the SE quarter of Section 32, T24S, R37E, MDM. Continue W along the Kern and Tulare County boundary, until that point which is the NW corner of T25S, R32E, MDM. Continue S following R32E lines to the NW corner of T31S, R32E, MDM. Continue W to the NW corner of T31S, R31E, MDM. Continue S to the SW corner of T32S, R31E, MDM. Continue

W to SW corner of SE quarter of Section 34, T32S, R30E, MDM. Continue S to SW corner of T11N, R17W, SBM. Continue E along south boundary of T11N, SBM to SW corner of T11N, R7W, SBM. Continue S to SW corner of T9N, R7W, SBM. Continue E along south boundary of T9N, SBM to SW corner of T9N, R1E, SBM. Continue S along west boundary of R1E, SMB to Riverside County line at the SW corner of T1S, R1E, SBM. Continue E along south boundary of T1S, SBM (Riverside County Line) to SW corner of T1S, R10E, SBM. Continue S along west boundary of R10E, SBM to Imperial County line at the SW corner of T8S, R10E, SBM. Continue W along Imperial and Riverside county line to NW corner of T9S, R9E, SBM. Continue S along the boundary between Imperial and San Diego Counties, along the west edge of R9E, SBM to the south boundary of Imperial County/California state line. Follow the California state line west to Arizona state line, then north to Nevada state line, then continuing NW back to start at the point which is the NW corner of Section 1, T17N, R14E, SBM

\$1.00 additional per hour for portions of SAN LUIS OBISPO, KERN, SANTA BARBARA & VENTURA as defined below:

That area within the following Boundary: Begin approximately 5 miles north of the community of Cholame, on the Monterey County and San Luis Obispo County boundary at the NW corner of T25S, R16E, Mt. Diablo Meridian. Continue south along the west side of R16E to the SW corner of T30S, R16E, MDM. Continue E to SW corner of T30S, R17E, MDM. Continue S to SW corner of T31S, R17E, MDM. Continue E to SW corner of T31S, R18E, MDM. Continue S along West side of R18E, MDM as it crosses into San Bernardino Meridian numbering area and becomes R30W. Follow the west side of R30W, SBM to the SW corner of T9N, R30W, SBM. Continue E along the south edge of T9N, SBM to the Santa Barbara County and Ventura County boundary at that point which is the SW corner of Section 34. T9N, R24W, SBM, continue S along the Ventura County line to that point which is the SW corner of the SE quarter of Section 32, T7N, R24W, SBM. Continue E along the south edge of T7N, SBM to the SE corner to T7N, R21W, SBM. Continue N along East side of R21W, SBM to Ventura County and Kern County boundary at the NE corner of T8N, R21W. Continue W along the Ventura County and Kern County boundary to the SE corner of T9N, R21W. Continue North along the East edge of R21W, SBM to the NE corner of T12N, R21W, SBM. Continue West along the north edge of T12N, SBM to the SE corner of T32S, R21E, MDM. [T12N SBM is a think strip between T11N SBM and T32S MDM]. Continue North along the East side of R21E, MDM to the Kings County and Kern County border at the NE corner of T25S, R21E, MDM, continue West along the Kings County and Kern County Boundary until the intersection of San Luis Obispo County. Continue west along the Kings County and San Luis Obispo County boundary until the intersection with Monterey County. Continue West along the Monterey County and San Luis Obispo County boundary to the beginning point at the NW corner of T25S, R16E, MDM.

\$2.00 additional per hour for INYO and MONO Counties and the Northern portion of SAN BERNARDINO County as defined below:

That area within the following Boundary: Begin at the intersection of the northern boundary of Mono County and the California state line at the point which is the center of Section 17, T10N, R22E, Mt. Diablo Meridian. Continue S then SE along the entire western boundary of Mono County, until it reaches Inyo County at the point which is the NE corner of the Western half of the NW quarter of Section 2, T8S, R29E, MDM. Continue SSE along the entire western boundary of Inyo County, until the intersection with Kern County at the point which is the SW corner of the SE 1/4 of Section 32, T24S, R37E, MDM. Continue E along the Inyo and Kern County boundary until the intersection with San Bernardino County at that point which is the SE corner of section 34, T24S, R40E, MDM. Continue E along the Inyo and San Bernardino County boundary until the point which is the NE corner of the Western half of the NW quarter of Section 6, T25S, R42E, MDM. Continue S to that point which is the SW corner of the NW quarter of Section 6, T27S, R42E, MDM. Continue E in a straight line to the California and Nevada state border at the point which is the NW corner of Section 1, T17N, R14E, San Bernardino Meridian. Then continue NW along the state line to the starting point, which is the center of Section 18, T10N, R22E, MDM.

REMAINING AREA NOT DEFINED ABOVE RECIEVES BASE RATE

 ENGI0012-004 08/01/2015

	Rates	Fringes
OPERATOR: Power Equipment		
(DREDGING)		
(1) Leverman.....	\$ 49.50	23.60
(2) Dredge dozer.....	\$ 43.53	23.60
(3) Deckmate.....	\$ 43.42	23.60
(4) Winch operator (stern winch on dredge).....	\$ 42.87	23.60
(5) Fireman-Oiler, Deckhand, Bargeman, Leveehand.....	\$ 42.33	23.60
(6) Barge Mate.....	\$ 42.94	23.60

 IRON0377-002 01/01/2017

	Rates	Fringes
Ironworkers:		
Fence Erector.....	\$ 29.58	21.59
Ornamental, Reinforcing and Structural.....	\$ 36.00	30.15

PREMIUM PAY:

\$6.00 additional per hour at the following locations:

China Lake Naval Test Station, Chocolate Mountains Naval

Reserve-Niland,
 Edwards AFB, Fort Irwin Military Station, Fort Irwin Training
 Center-Goldstone, San Clemente Island, San Nicholas Island,
 Susanville Federal Prison, 29 Palms - Marine Corps, U.S. Marine
 Base - Barstow, U.S. Naval Air Facility - Sealey, Vandenberg AFB

\$4.00 additional per hour at the following locations:

Army Defense Language Institute - Monterey, Fallon Air Base,
 Naval Post Graduate School - Monterey, Yermo Marine Corps
 Logistics Center

\$2.00 additional per hour at the following locations:

Port Hueneme, Port Mugu, U.S. Coast Guard Station - Two Rock

 LABO0300-001 07/01/2017

	Rates	Fringes
Brick Tender.....	\$ 31.36	17.82

 LABO0300-003 07/03/2017

	Rates	Fringes
LABORER (TUNNEL)		
GROUP 1.....	\$ 39.04	18.24
GROUP 2.....	\$ 39.36	18.24
GROUP 3.....	\$ 39.82	18.24
GROUP 4.....	\$ 40.51	18.24
LABORER		
GROUP 1.....	\$ 33.19	18.24
GROUP 2.....	\$ 33.74	18.24
GROUP 3.....	\$ 34.29	18.24
GROUP 4.....	\$ 35.84	18.24
GROUP 5.....	\$ 36.19	18.24

LABORER CLASSIFICATIONS

GROUP 1: Cleaning and handling of panel forms; Concrete screeding for rough strike-off; Concrete, water curing; Demolition laborer, the cleaning of brick if performed by a worker performing any other phase of demolition work, and the cleaning of lumber; Fire watcher, limber, brush loader, piler and debris handler; Flag person; Gas, oil and/or water pipeline laborer; Laborer, asphalt-rubber material loader; Laborer, general or construction; Laborer, general clean-up; Laborer, landscaping; Laborer, jetting; Laborer, temporary water and air lines; Material hose operator (walls, slabs, floors and decks); Plugging, filling of shee bolt holes; Dry packing of concrete; Railroad maintenance, repair track person and road beds; Streetcar and railroad construction track laborers; Rigging and signaling; Scaler; Slip form raiser; Tar and mortar; Tool crib or tool house laborer; Traffic control by any method; Window cleaner;

Wire mesh pulling - all concrete pouring operations

GROUP 2: Asphalt shoveler; Cement dumper (on 1 yd. or larger mixer and handling bulk cement); Cesspool digger and installer; Chucktender; Chute handler, pouring concrete, the handling of the chute from readymix trucks, such as walls, slabs, decks, floors, foundation, footings, curbs, gutters and sidewalks; Concrete curer, impervious membrane and form oiler; Cutting torch operator (demolition); Fine grader, highways and street paving, airport, runways and similar type heavy construction; Gas, oil and/or water pipeline wrapper - pot tender and form person; Guinea chaser; Headerboard person - asphalt; Laborer, packing rod steel and pans; Membrane vapor barrier installer; Power broom sweeper (small); Riprap stonepaver, placing stone or wet sacked concrete; Roto scraper and tiller; Sandblaster (pot tender); Septic tank digger and installer(lead); Tank scaler and cleaner; Tree climber, faller, chain saw operator, Pittsburgh chipper and similar type brush shredder; Underground laborer, including caisson bellower

GROUP 3: Buggymobile person; Concrete cutting torch; Concrete pile cutter; Driller, jackhammer, 2-1/2 ft. drill steel or longer; Dri-pak-it machine; Gas, oil and/or water pipeline wrapper, 6-in. pipe and over, by any method, inside and out; High scaler (including drilling of same); Hydro seeder and similar type; Impact wrench multi-plate; Kettle person, pot person and workers applying asphalt, lay-kold, creosote, lime caustic and similar type materials ("applying" means applying, dipping, brushing or handling of such materials for pipe wrapping and waterproofing); Operator of pneumatic, gas, electric tools, vibrating machine, pavement breaker, air blasting, come-alongs, and similar mechanical tools not separately classified herein; Pipelayer's backup person, coating, grouting, making of joints, sealing, caulking, diapering and including rubber gasket joints, pointing and any and all other services; Rock slinger; Rotary scarifier or multiple head concrete chipping scarifier; Steel headerboard and guideline setter; Tamper, Barko, Wacker and similar type; Trenching machine, hand-propelled

GROUP 4: Asphalt raker, lute person, ironer, asphalt dump person, and asphalt spreader boxes (all types); Concrete core cutter (walls, floors or ceilings), grinder or sander; Concrete saw person, cutting walls or flat work, scoring old or new concrete; Cribber, shorer, lagging, sheeting and trench bracing, hand-guided lagging hammer; Head rock slinger; Laborer, asphalt- rubber distributor boot person; Laser beam in connection with laborers' work; Oversize concrete vibrator operator, 70 lbs. and over; Pipelayer performing all services in the laying and installation of pipe from the point of receiving pipe in the ditch until completion of operation, including any and all forms of tubular material, whether pipe, metallic or non-metallic, conduit and any other stationary type of tubular device used for the conveying of any substance or element, whether water, sewage, solid gas, air, or other product whatsoever

and without regard to the nature of material from which the tubular material is fabricated; No-joint pipe and stripping of same; Prefabricated manhole installer; Sandblaster (nozzle person), water blasting, Porta Shot-Blast

GROUP 5: Blaster powder, all work of loading holes, placing and blasting of all powder and explosives of whatever type, regardless of method used for such loading and placing; Driller: All power drills, excluding jackhammer, whether core, diamond, wagon, track, multiple unit, and any and all other types of mechanical drills without regard to the form of motive power; Toxic waste removal

TUNNEL LABORER CLASSIFICATIONS

GROUP 1: Batch plant laborer; Changehouse person; Dump person; Dump person (outside); Swamper (brake person and switch person on tunnel work); Tunnel materials handling person; Nipper; Pot tender, using mastic or other materials (for example, but not by way of limitation, shotcrete, etc.)

GROUP 2: Chucktender, cabetender; Loading and unloading agitator cars;; Vibrator person, jack hammer, pneumatic tools (except driller); Bull gang mucker, track person; Concrete crew, including rodder and spreader

GROUP 3: Blaster, driller, powder person; Chemical grout jet person; Cherry picker person; Grout gun person; Grout mixer person; Grout pump person; Jackleg miner; Jumbo person; Kemper and other pneumatic concrete placer operator; Miner, tunnel (hand or machine); Nozzle person; Operating of troweling and/or grouting machines; Powder person (primer house); Primer person; Sandblaster; Shotcrete person; Steel form raiser and setter; Timber person, retimber person, wood or steel; Tunnel Concrete finisher

GROUP 4: Diamond driller; Sandblaster; Shaft and raise work

LABO0300-005 01/01/2018

	Rates	Fringes
Asbestos Removal Laborer.....	\$ 33.19	17.78

SCOPE OF WORK: Includes site mobilization, initial site cleanup, site preparation, removal of asbestos-containing material and toxic waste, encapsulation, enclosure and disposal of asbestos- containing materials and toxic waste by hand or with equipment or machinery; scaffolding, fabrication of temporary wooden barriers and assembly of decontamination stations.

LABO0345-001 07/02/2017

	Rates	Fringes
--	-------	---------

LABORER (GUNITE)

GROUP 1.....	\$ 41.08	17.39
GROUP 2.....	\$ 40.13	17.39
GROUP 3.....	\$ 36.59	17.39

FOOTNOTE: GUNITE PREMIUM PAY: Workers working from a Bosn'n's Chair or suspended from a rope or cable shall receive 40 cents per hour above the foregoing applicable classification rates. Workers doing gunite and/or shotcrete work in a tunnel shall receive 35 cents per hour above the foregoing applicable classification rates, paid on a portal-to-portal basis. Any work performed on, in or above any smoke stack, silo, storage elevator or similar type of structure, when such structure is in excess of 75'-0" above base level and which work must be performed in whole or in part more than 75'-0" above base level, that work performed above the 75'-0" level shall be compensated for at 35 cents per hour above the applicable classification wage rate.

GUNITE LABORER CLASSIFICATIONS

- GROUP 1: Rodmen, Nozzlemen
- GROUP 2: Gunmen
- GROUP 3: Reboundmen

LABO1184-001 07/01/2017

	Rates	Fringes
Laborers: (HORIZONTAL DIRECTIONAL DRILLING)		
(1) Drilling Crew Laborer...	\$ 34.65	13.20
(2) Vehicle Operator/Hauler.	\$ 34.82	13.20
(3) Horizontal Directional Drill Operator.....	\$ 36.67	13.20
(4) Electronic Tracking Locator.....	\$ 38.67	13.20
Laborers: (STRIPING/SLURRY SEAL)		
GROUP 1.....	\$ 35.86	16.21
GROUP 2.....	\$ 37.16	16.21
GROUP 3.....	\$ 39.17	16.21
GROUP 4.....	\$ 40.91	16.21

LABORERS - STRIPING CLASSIFICATIONS

- GROUP 1: Protective coating, pavement sealing, including repair and filling of cracks by any method on any surface in parking lots, game courts and playgrounds; carstops; operation of all related machinery and equipment; equipment repair technician
- GROUP 2: Traffic surface abrasive blaster; pot tender - removal of all traffic lines and markings by any method

(sandblasting, waterblasting, grinding, etc.) and preparation of surface for coatings. Traffic control person: controlling and directing traffic through both conventional and moving lane closures; operation of all related machinery and equipment

GROUP 3: Traffic delineating device applicator: Layout and application of pavement markers, delineating signs, rumble and traffic bars, adhesives, guide markers, other traffic delineating devices including traffic control. This category includes all traffic related surface preparation (sandblasting, waterblasting, grinding) as part of the application process. Traffic protective delineating system installer: removes, relocates, installs, permanently affixed roadside and parking delineation barricades, fencing, cable anchor, guard rail, reference signs, monument markers; operation of all related machinery and equipment; power broom sweeper

GROUP 4: Striper: layout and application of traffic stripes and markings; hot thermo plastic; tape traffic stripes and markings, including traffic control; operation of all related machinery and equipment

LABO1414-001 08/02/2017

	Rates	Fringes
LABORER		
PLASTER CLEAN-UP LABORER....	\$ 32.50	18.29
PLASTER TENDER.....	\$ 35.05	18.29

Work on a swing stage scaffold: \$1.00 per hour additional.

PAIN0036-001 01/01/2018

	Rates	Fringes
Painters: (Including Lead Abatement)		
(1) Repaint (excludes San Diego County).....	\$ 27.59	14.14
(2) All Other Work.....	\$ 31.12	14.14

REPAINT of any previously painted structure. Exceptions: work involving the aerospace industry, breweries, commercial recreational facilities, hotels which operate commercial establishments as part of hotel service, and sports facilities.

PAIN0036-006 10/01/2017

	Rates	Fringes
DRYWALL FINISHER/TAPER		
Antelope Valley North of		

the following Boundary:

Kern County Line to Hwy.

#5, South on Hwy. #5 to

Hwy. N2, East on N2 to

Palmdale Blvd., to Hwy.

#14, South to Hwy. #18,

East to Hwy. #395.....\$ 32.05

16.82

Remainder of Los Angeles

County.....\$ 38.58

18.64

PAIN0036-015 06/01/2017

Rates

Fringes

GLAZIER.....\$ 40.95

24.40

FOOTNOTE: Additional \$1.25 per hour for work in a condor,
from the third (3rd) floor and up Additional \$1.25 per
hour for work on the outside of the building from a swing
stage or any suspended contrivance, from the ground up

PAIN1247-002 01/01/2018

Rates

Fringes

SOFT FLOOR LAYER.....\$ 32.35

14.56

PLAS0200-009 08/02/2017

Rates

Fringes

PLASTERER.....\$ 41.26

14.46

PLAS0500-002 07/01/2016

Rates

Fringes

CEMENT MASON/CONCRETE FINISHER...\$ 33.30

23.33

PLUM0016-001 07/01/2017

Rates

Fringes

PLUMBER/PIPEFITTER

Plumber and Pipefitter

All other work except

work on new additions and

remodeling of bars,

restaurant, stores and

commercial buildings not

to exceed 5,000 sq. ft.

of floor space and work

on strip malls, light

commercial, tenant

improvement and remodel

work.....\$ 49.28

21.61

Work ONLY on new additions

and remodeling of bars,
 restaurant, stores and
 commercial buildings not
 to exceed 5,000 sq. ft. of
 floor space.....\$ 47.76 20.63
 Work ONLY on strip malls,
 light commercial, tenant
 improvement and remodel
 work.....\$ 36.91 18.96

 PLUM0078-001 07/01/2016

	Rates	Fringes
PLUMBER		
Landscape/Irrigation Fitter.\$ 44.16	44.16	25.19
Sewer & Storm Drain Work....\$ 44.16	44.16	25.19

 ROOF0036-002 08/01/2017

	Rates	Fringes
ROOFER.....\$ 37.07	37.07	16.17

FOOTNOTE: Pitch premium: Work on which employees are exposed to pitch fumes or required to handle pitch, pitch base or pitch impregnated products, or any material containing coal tar pitch, the entire roofing crew shall receive \$1.75 per hour "pitch premium" pay.

 SFCA0669-013 04/01/2017

DOES NOT INCLUDE THE CITY OF POMONA, CATALINA ISLAND, AND THAT PART OF LOS ANGELES COUNTY WITHIN 25 MILES OF THE CITY LIMITS OF LOS ANGELES:

	Rates	Fringes
SPRINKLER FITTER.....\$ 39.07	39.07	15.84

 SFCA0709-005 07/01/2015

THE CITY OF POMOMA, CATALINA ISLAND, AND THAT PART OF LOS ANGELES COUNTY WITHIN 25 MILES OF THE CITY LIMITS OF LOS ANGELES:

	Rates	Fringes
SPRINKLER FITTER (Fire).....\$ 42.93	42.93	24.04

 SHEE0105-002 01/01/2018

LOS ANGELES (South of a straight line between gorman and Big Pines including Catalina Island)

	Rates	Fringes
SHEET METAL WORKER		
(1) Light Commercial: Work on general sheet metal and heating and AC up to 4000 sq ft.....	\$ 25.67	10.42
(2) Modernization : Excluding New Construction - Under 5000 sq. ft. Does not include modification, upgrades, energy management, or conservation improvements of central heating and AC equipment.....	\$ 42.78	27.96

SHEE0105-003 01/01/2018

LOS ANGELES (South of a straight line drawn between Gorman and Big Pines) and Catalina Island, INYO, KERN (Northeast part, East of Hwy 395), MONO ORANGE, RIVERSIDE, AND SAN BERNARDINO COUNTIES

	Rates	Fringes
SHEET METAL WORKER		
(1) Commercial - New Construction and Remodel work.....	\$ 42.78	27.96
(2) Industrial work including air pollution control systems, noise abatement, hand rails, guard rails, excluding aritechtrual sheet metal work, excluding A-C, heating, ventilating systems for human comfort....	\$ 42.78	27.96

SHEE0105-004 01/01/2018

KERN (Excluding portion East of Hwy 395) & LOS ANGELES (North of a straight line drawn between Gorman and Big Pines including Cities of Lancaster and Palmdale) COUNTIES

	Rates	Fringes
SHEET METAL WORKER.....	\$ 32.38	26.99

TEAM0011-002 07/01/2017

	Rates	Fringes
TRUCK DRIVER GROUP 1.....	\$ 29.59	27.74

GROUP 2.....	\$ 29.74	27.74
GROUP 3.....	\$ 29.87	27.74
GROUP 4.....	\$ 30.06	27.74
GROUP 5.....	\$ 30.09	27.74
GROUP 6.....	\$ 30.12	27.74
GROUP 7.....	\$ 30.37	27.74
GROUP 8.....	\$ 30.62	27.74
GROUP 9.....	\$ 30.82	27.74
GROUP 10.....	\$ 31.12	27.74
GROUP 11.....	\$ 31.62	27.74
GROUP 12.....	\$ 32.05	27.74

WORK ON ALL MILITARY BASES:

PREMIUM PAY: \$3.00 per hour additional.

[29 palms Marine Base, Camp Roberts, China Lake, Edwards AFB, El Centro Naval Facility, Fort Irwin, Marine Corps Logistics Base at Nebo & Yermo, Mountain Warfare Training Center, Bridgeport, Point Arguello, Point Conception, Vandenberg AFB]

TRUCK DRIVERS CLASSIFICATIONS

GROUP 1: Truck driver

GROUP 2: Driver of vehicle or combination of vehicles - 2 axles; Traffic control pilot car excluding moving heavy equipment permit load; Truck mounted broom

GROUP 3: Driver of vehicle or combination of vehicles - 3 axles; Boot person; Cement mason distribution truck; Fuel truck driver; Water truck - 2 axle; Dump truck, less than 16 yds. water level; Erosion control driver

GROUP 4: Driver of transit mix truck, under 3 yds.; Dumpcrete truck, less than 6-1/2 yds. water level

GROUP 5: Water truck, 3 or more axles; Truck greaser and tire person (\$0.50 additional for tire person); Pipeline and utility working truck driver, including winch truck and plastic fusion, limited to pipeline and utility work; Slurry truck driver

GROUP 6: Transit mix truck, 3 yds. or more; Dumpcrete truck, 6-1/2 yds. water level and over; Vehicle or combination of vehicles - 4 or more axles; Oil spreader truck; Dump truck, 16 yds. to 25 yds. water level

GROUP 7: A Frame, Swedish crane or similar; Forklift driver; Ross carrier driver

GROUP 8: Dump truck, 25 yds. to 49 yds. water level; Truck repair person; Water pull - single engine; Welder

GROUP 9: Truck repair person/welder; Low bed driver, 9 axles or over

GROUP 10: Dump truck - 50 yds. or more water level; Water pull - single engine with attachment

GROUP 11: Water pull - twin engine; Water pull - twin engine with attachments; Winch truck driver - \$1.25 additional when operating winch or similar special attachments

GROUP 12: Boom Truck 17K and above

WELDERS - Receive rate prescribed for craft performing operation to which welding is incidental.
=====

Note: Executive Order (EO) 13706, Establishing Paid Sick Leave for Federal Contractors applies to all contracts subject to the Davis-Bacon Act for which the contract is awarded (and any solicitation was issued) on or after January 1, 2017. If this contract is covered by the EO, the contractor must provide employees with 1 hour of paid sick leave for every 30 hours they work, up to 56 hours of paid sick leave each year. Employees must be permitted to use paid sick leave for their own illness, injury or other health-related needs, including preventive care; to assist a family member (or person who is like family to the employee) who is ill, injured, or has other health-related needs, including preventive care; or for reasons resulting from, or to assist a family member (or person who is like family to the employee) who is a victim of, domestic violence, sexual assault, or stalking. Additional information on contractor requirements and worker protections under the EO is available at www.dol.gov/whd/govcontracts.

Unlisted classifications needed for work not included within the scope of the classifications listed may be added after award only as provided in the labor standards contract clauses (29CFR 5.5 (a) (1) (ii)).

The body of each wage determination lists the classification and wage rates that have been found to be prevailing for the cited type(s) of construction in the area covered by the wage determination. The classifications are listed in alphabetical order of "identifiers" that indicate whether the particular rate is a union rate (current union negotiated rate for local), a survey rate (weighted average rate) or a union average rate (weighted union average rate).

Union Rate Identifiers

A four letter classification abbreviation identifier enclosed in dotted lines beginning with characters other than "SU" or "UAVG" denotes that the union classification and rate were prevailing for that classification in the survey. Example:

PLUM0198-005 07/01/2014. PLUM is an abbreviation identifier of the union which prevailed in the survey for this classification, which in this example would be Plumbers. 0198 indicates the local union number or district council number where applicable, i.e., Plumbers Local 0198. The next number, 005 in the example, is an internal number used in processing the wage determination. 07/01/2014 is the effective date of the most current negotiated rate, which in this example is July 1, 2014.

Union prevailing wage rates are updated to reflect all rate changes in the collective bargaining agreement (CBA) governing this classification and rate.

Survey Rate Identifiers

Classifications listed under the "SU" identifier indicate that no one rate prevailed for this classification in the survey and the published rate is derived by computing a weighted average rate based on all the rates reported in the survey for that classification. As this weighted average rate includes all rates reported in the survey, it may include both union and non-union rates. Example: SULA2012-007 5/13/2014. SU indicates the rates are survey rates based on a weighted average calculation of rates and are not majority rates. LA indicates the State of Louisiana. 2012 is the year of survey on which these classifications and rates are based. The next number, 007 in the example, is an internal number used in producing the wage determination. 5/13/2014 indicates the survey completion date for the classifications and rates under that identifier.

Survey wage rates are not updated and remain in effect until a new survey is conducted.

Union Average Rate Identifiers

Classification(s) listed under the UAVG identifier indicate that no single majority rate prevailed for those classifications; however, 100% of the data reported for the classifications was union data. EXAMPLE: UAVG-OH-0010 08/29/2014. UAVG indicates that the rate is a weighted union average rate. OH indicates the state. The next number, 0010 in the example, is an internal number used in producing the wage determination. 08/29/2014 indicates the survey completion date for the classifications and rates under that identifier.

A UAVG rate will be updated once a year, usually in January of each year, to reflect a weighted average of the current negotiated/CBA rate of the union locals from which the rate is based.

WAGE DETERMINATION APPEALS PROCESS

1.) Has there been an initial decision in the matter? This can

be:

- * an existing published wage determination
- * a survey underlying a wage determination
- * a Wage and Hour Division letter setting forth a position on a wage determination matter
- * a conformance (additional classification and rate) ruling

On survey related matters, initial contact, including requests for summaries of surveys, should be with the Wage and Hour Regional Office for the area in which the survey was conducted because those Regional Offices have responsibility for the Davis-Bacon survey program. If the response from this initial contact is not satisfactory, then the process described in 2.) and 3.) should be followed.

With regard to any other matter not yet ripe for the formal process described here, initial contact should be with the Branch of Construction Wage Determinations. Write to:

Branch of Construction Wage Determinations
Wage and Hour Division
U.S. Department of Labor
200 Constitution Avenue, N.W.
Washington, DC 20210

2.) If the answer to the question in 1.) is yes, then an interested party (those affected by the action) can request review and reconsideration from the Wage and Hour Administrator (See 29 CFR Part 1.8 and 29 CFR Part 7). Write to:

Wage and Hour Administrator
U.S. Department of Labor
200 Constitution Avenue, N.W.
Washington, DC 20210

The request should be accompanied by a full statement of the interested party's position and by any information (wage payment data, project description, area practice material, etc.) that the requestor considers relevant to the issue.

3.) If the decision of the Administrator is not favorable, an interested party may appeal directly to the Administrative Review Board (formerly the Wage Appeals Board). Write to:

Administrative Review Board
U.S. Department of Labor
200 Constitution Avenue, N.W.
Washington, DC 20210

4.) All decisions by the Administrative Review Board are final.

=====
END OF GENERAL DECISION

APPENDIX F

LOS ANGELES COUNTY FLOOD CONTROL PERMIT



**COUNTY OF LOS ANGELES
DEPARTMENT OF PUBLIC WORKS**
900 SOUTH FREMONT AVENUE
ALHAMBRA, CALIFORNIA 91803

PERMIT#: FCDP2017006814
PERMIT STATUS: Issued
Page 1 of 11
ISSUE DATE: 03/11/2018
BY: Karlo Manalo
PERMIT OFFICE: PO3
5530 W. 83rd Street
Los Angeles, CA 90045
(310)-649-6300
(310) 215-3952 Fax

PERMIT TYPE: Flood
PERMIT CLASS/SUBCLASS: Construction

APPLICANT City of Agoura Hills Robert Cortes	ADDRESS 30001 Ladyface Court Agoura Hills, CA 91301	Business: (818)597-7329 email: rcortes@ci.agoura-hills.ca.us
LOCATION: INTERSECTION OF CHESEBORO CYN CHANNEL AND W DRIVER AVE, AGOORA HILLS FLOOD FACILITY NAME: CHESEBORO CANYON CHANNEL		PROJECT/WORK ORDER NO.

INSPECTION REQUIRED

CALL PERMIT OFFICE AT LEAST ONE (1) WORKING DAY BEFORE STARTING WORK UNDER THIS PERMIT.
FAILURE TO DO SO IS CAUSE FOR REVOCATION OF THIS PERMIT. THIS PERMIT IS VOID IF WORK IS NOT
STARTED BY 09/07/2018

<p>PROJECT DESCRIPTION: To authorize the work described below affecting the subject facility in accordance with the submitted plans, Los Angeles County Flood Control District (LACFCD) Drawing No. 422-F53 (Los Angeles County Department of Public Works Drawing No. PF577268).</p> <p>WORK DESCRIPTION: Construct a 64-ft pre-fabricated pedestrian bridge resting on two 14' L x 36" W abutment cap on caissons over the subject LACFCD facility and over LACFCD fee-owned property, per approved plans.</p> <p>WORK SHALL NOT START UNTIL THE DISTRICT HAS APPROVED THE CONTRACTOR'S INSURANCE (INCLUDING ADDITIONAL INSURED ENDORSEMENT).</p> <p>=====</p> <p>LEGACY PERMIT CREATED IN EDAPTS Permit No.: PCFL 201700602</p>

PROJECT CONDITIONS:

1. The City of Agoura Hills and its contractors acknowledge that during construction of the pedestrian bridge and its appurtenant structures and subsequent maintenance of them no equipment or personnel shall be present in the channel during storm season. The City and its contractors must notify Stormwater Maintenance Division (Hansen Yard) at telephone (818) 896-0594 (8:00am to 4:00pm) and Stormwater Engineering Division (Operations Section) at telephone (626) 458-6177 and provide them with a schedule of activities at least 72 hours before starting any work under the permit(s).
2. The City of Agoura Hills acknowledges that Cheseboro Canyon Channel and its laterals and appurtenant structures are working flood control facilities, and the use of the LACFCD's right of way for the proposed pedestrian bridge, including any features proposed within LACFCD's right of way, shall not decrease the storm drains' capacity, or interfere with LACFCD or its contractors' operation and maintenance activities of the storm drains and their appurtenant structures.
3. The City of Agoura Hills acknowledges it is using LACFCD's right of way that is associated with working flood protection facilities that serve an overarching public safety benefit. The City of Agoura Hills also acknowledges that it, its contractors, and the pedestrian bridge users and their horses or pets may be subject to impacts, including but not limited to visual, noise, dust and other noisome or inconvenient impacts during periods when LACFCD or its contractors operate, maintain, repair or rehabilitate the facilities. The City of Agoura Hills also acknowledges that LACFCD has facilities that connect to, are tributary to or support the channel. Therefore, the City of Agoura Hills shall not oppose or interfere with LACFCD's activities for the operation, maintenance, repair or rehabilitation of the channel, its laterals, and other LACFCD facilities that connect to, are tributary to or support the channel.
4. The City of Agoura Hills shall be solely responsible for complying with all local, State and Federal laws in its use of LACFCD's right of way, including but not limited to the proposed pedestrian bridge and any features and their operation and maintenance.
5. The City of Agoura Hills shall not install any features that impose any additional regulatory burden on the LACFCD in its operation and maintenance of the channel and its appurtenant structures (e.g., stream gages, fences, access ramps, etc.). Examples of potential additional regulatory burdens include but are not limited to:
 - Preparation of CEQA documents
 - Acquisition of permits or amendments to existing permits
 - Compensatory mitigation
 - Bird nesting season restriction
6. The City of Agoura Hills shall defend and hold the LACFCD harmless for any damages or violation of local, State and Federal laws that result from its or its contractors' use of LACFCD's right of way.
7. In the event LACFCD, at its sole discretion, has need for its right of way in the area where the proposed improvement is located, or the City of Agoura Hills' use of LACFCD's right of way is causing increased damages or nuisance to other properties, the City shall at no cost to the LACFCD remove from LACFCD's right of way all features it has installed or accommodate LACFCD's request to its satisfaction.
8. The Contractor shall be extra cautious working in the vicinity of the existing storm drain. For the purpose of soil compaction, the Contractor shall use hand-held equipment when working adjacent to the existing storm drain and wing wall in order to not cause any structural damage to the existing structures.
9. Extra precautions shall be exercised to prevent damage to the District's structures by reason of crossing/bridge construction operations. If in the opinion of the Director permittee fails to take proper precautions, the Director may direct all operations on the District's right of way.
10. Unless otherwise indicated in this permit, all work authorized by this permit shall conform to the latest edition of the Standard Specifications for Public Works Construction (Greenbook), as amended, and the latest edition of the Los Angeles County Department of Public Works "Additions and Amendments to the Standard Specifications for Public Works Construction", as amended.
11. Permittee is notified that, in accordance with the STATE OF CALIFORNIA CONSTRUCTION SAFETY ORDERS, Section 1503, the Permittee or their contractor must have a permit from CAL/OSHA if the excavation authorized herein is more than 5 feet deep.
12. This permit shall not be exercised during inclement weather or when the 5-day forecast predicts rain. No activities will be allowed during storm events.
13. Any structure or portions thereof placed on District right of way must be removed, revised, and/or relocated by Permittee without cost to the District. or any other public agency the District shall so designate. should future activities or policy so require.
14. Permittee shall protect all District facilities where the proposed work comes in close proximity to the District's facilities
15. If any water-borne debris becomes deposited on the bridge/crossing structure, falsework, cofferdams, or other facilities installed by permittee, such debris shall be immediately removed from the channel at their expense. All equipment shall be removed from the channel during periods of precipitation.

16. In the event the District's facility fails or needs to be replaced or repaired after the improvements have been constructed, the permittee shall be responsible for all costs and expenses to the District in excess of costs that would have been incurred by the District to replace the facility had said land been left vacant.
17. No additional structures shall be constructed within the District's right of way without prior written permission from the Los Angeles County Department of Public Works/Flood Control District.
18. Issuance of this permit shall not be construed as an obligation on the part of this District for the operation and maintenance of the proposed facilities.
19. Issuance of this permit shall not be construed as an obligation on the part of the District to assume responsibility for any damages incurred to the permittee's improvements in the event of storm drain and/or channel failure or flooding from rain storms.
20. Prior to any construction work, the current condition of the existing storm drain and wing wall shall be inspected and documented. After the completion of construction, they shall be re-inspected and monitored for the possible damages. In the event that any damage is identified at any time, immediate replacement or repair to the satisfaction of LACDPW will be required at the Permittee's expense.
21. Permittee shall provide a minimum 48 hour advanced notice to all adjacent property owners or occupants within a 100 foot radius of the project site; and call the local Stormwater Maintenance Division yard at least 24 hours before starting work. The notice shall be written in the form of a letter, doorhanger, or flyer; and provide sufficient information regarding the project including the scope of work, schedule of work, working hours and a human contact to handle questions. Evidence of such notice must be produced upon demand by any District representative.
 - a. Hansen Yard (West) (818) 896-0594
 - b. Longden Yard (East) (626) 445-7630
 - c. Imperial Yard (South) (562) 861-0316
22. During the period of operations conducted under the permit, permittee shall maintain in effect an insurance policy (minimum of \$2 million) naming the Los Angeles County Flood Control District and Los Angeles County as co-insured with respect to the permitted operations. A copy of this policy shall be submitted to the District for inclusion in its files for the duration of the permit. Expiration or cancellation of the insurance policy shall result revocation of this permit.
23. Additional Attachment: Use Agreement No. 18-04 (Project No. M1723008)

Attachments: Los Angeles County Flood Permit Standard Provisions, Best Management Practices(BMPs)

FEE NAME	FEE CODE	AMOUNT
PCISSFLD	535656	\$122.00
Security Deposit - Flood	00041252	\$7,000.00
PCBRGPLCK1	535657	\$4,878.00
	TOTAL FEES:	\$12,000.00

Performance of work activity under this permit is tantamount to agreeing to the following terms:

1. Permittee is hereby permitted to perform the scope of work described above at the location described above, subject to all applicable provisions of the Flood Control Channels Ordinance (Chapter 20.94 of Title 20, Los Angeles County Code), County of Los Angeles Highway Permit Ordinance (Division 1 of Title 16, Los Angeles County Code), and/or any Municipal Code or Ordinance governing the area where this work is to be done.
2. Permittee's activities in connection with this Permit shall also be subject to the provisions and conditions contained in this Permit and any attachments, which are incorporated herein.
3. **INSPECTION REQUIRED** - Contact the Permit Office indicated on the Permit at least one (1) working day before starting any work. Failure to do so may result in this permit being suspended or revoked.
4. Compliance with Section 8771 of the State of California Business and Professions Code for the preservation and/or perpetuation of existing land survey monuments.
5. Compliance with Chapter 12.80 Stormwater and Runoff Pollution Control of the Los Angeles County Code, and the Best Management Practices (BMPs) Attachment.
6. This permit must be made available for inspection at the work site upon request by a County or District representative, or law enforcement official.
7. This permit will expire if the work is not commenced within 180 days from the date of permit issuance.
8. Upon completion of work, contact the Permit Office indicated in this Permit no later than the next working day. Failure to do so may result in additional fees assessed.
9. This Permit is revocable by the District if the District determines that the public interest and welfare require such revocation and shall be deemed void if the Permittee is not in compliance with Section 3800 of the Labor Code.

**LOS ANGELES COUNTY FLOOD CONTROL DISTRICT
STANDARD PERMIT PROVISIONS**

1. This permit is valid only for the purpose specified herein. No change of purpose as outlined in application or drawings submitted with application is permitted except upon written permission of the Chief Engineer or his representative.
2. Activities and uses authorized under this permit are subject to any instructions of the Chief Engineer or his representative. **ALL INSTRUCTIONS MUST BE STRICTLY OBSERVED.**
3. Permittee shall be responsible for notifying their contractor and all subcontractors of the provisions of this permit.
4. Permittee (including its contractors and subcontractors) shall indemnify, defend (with counsel reasonably satisfactory to District and the County of Los Angeles), and hold harmless District and the County of Los Angeles, and their elected and appointed officers, employees and agents, from and against any and all claims, expenses (including court costs and reasonable attorney and expert witness fees) demands, liabilities, losses, or causes of action of whatsoever nature or character, for injury, illness or death or loss of, damage to or destruction of property which arises out of, or is in any way connected to, the activities of Permittee described in this Permit.

This indemnification shall survive in its entirety the termination or revocation of this Permit, and shall remain in full force and effect in perpetuity, unless agreed to otherwise in writing by the District.

5. Permittee shall protect all District facilities where the proposed work comes in close proximity to the District facilities. Any damage caused to Flood Control structures by reason of exercise of this permit shall be repaired, at the permittee's sole expense, to the satisfaction of the District. Should the permittee neglect to promptly make repairs, the District may perform such work or have others perform the work, and the permittee agrees to reimburse the District for all costs of the work so performed upon receipt of a statement thereof.
6. Any structure or portions thereof or plantings placed on District rights of way or which affect District structures must be removed, revised, and/or relocated by permittee without cost to the District, or any other public agency the District shall so designate, should future activities or policy so require.
7. Unless authorized by this permit, permittee shall not prune, deface, destroy or remove any tree or landscaping growing or to grow upon the District right of way.
8. This permit is valid only to the extent of District jurisdiction. Acquisition of permits required by other affected agencies and consent of underlying fee owner(s) of District easement lands are the responsibility of the permittee. **NOTHING CONTAINED IN THIS PERMIT SHALL BE CONSTRUED AS A RELINQUISHMENT OF ANY RIGHTS NOW HELD BY THE DISTRICT.**
9. This permit is subject to all prior unexpired permits, agreements, easements, privileges, or other rights, whether recorded or unrecorded, in the area specified by this permit. Permittee shall make his own arrangements with holders of such prior rights.
10. Ingress and egress shall be at locations approved by the District's representative.
11. Permittee shall keep the District's right of way clear of obstructions for through access at all times and shall not interfere with the activities of the District's representative. Permittee shall be prepared to remove all material or equipment upon notice to accommodate District's operation and maintenance needs.

12. Permittee shall not use District's right of way for the temporary or permanent storage of excavated materials, rock, sand, cement, or other material, or any equipment, except as specifically noted.
13. Unless otherwise specified herein, this permit may be revoked or canceled at any time by the Chief Engineer or his representative when required for District purposes.
14. Upon written notice of cancellation or revocation of this permit for any cause whatsoever, permittee shall restore District right of way and structures to their condition prior to the issuance of the permit and then shall vacate District property. Should permittee neglect to restore the premises or structures to a condition satisfactory to the Chief Engineer or his representative, the District may perform such work or have others perform the work, and the permittee agrees to reimburse the District for all costs of the work so performed upon receipt of a statement thereof.
15. Permittee will be subject to fines from the California Regional Water Quality Control Board, the California Department of Fish and Wildlife, and the United States Coast Guard for any water pollution resulting from these activities.
16. In the event of a District employee work stoppage, the Chief Engineer or his representative reserves the right to suspend all activity authorized under this permit which requires inspection by the District. Activity authorized by the permit shall not resume until District approval to do so is given.
17. Unless otherwise specifically provided, all costs incurred by permittee as a result of the conditions of the permit or exercise by District of any right, authority, or reservation contained therein shall be the sole responsibility of and shall be borne entirely by the permittee.

**Best Management Practices (BMPs)
Attachment**

The Los Angeles County Department of Public Works (LACDPW) requires Permittees and their contractors to implement a program to effectively control water pollution during all Permit construction projects. This project shall conform with the requirements of the following County Code and Permits:

- Los Angeles, California County Code Chapter 12.80 Stormwater and Runoff Pollution Control
- Waste Discharge Requirements for Municipal Separate Storm Water System (MS4) and Discharges within the Coastal Watersheds of Los Angeles County, Except Those Discharges Originating from the City of Long Beach (Order No. R4-2012-0175 as amended by State Water Board Order WQ 2015-0075 and Los Angeles Water Board Order R4-2012-0175-A01, National Pollutant Discharge Elimination System [NPDES] No. CAS004001)
- NPDES General Permit for Storm Water Discharges Associated with Construction and Land Disturbance Activities (Order No. 2009-0009-DWQ amended by 2010-0014-DWQ and 2012-0006-DWQ, NPDES No. CAS000002)

The Permittee or Authorized Representative and their contractors shall know and fully comply with the applicable provisions of these permits and Federal, State and local regulations that govern the Permittee or Authorized Representative's operations and the storm water discharges from the project site.

In order to ensure a minimum level of water quality control, the Permittee or Authorized Representative and their contractors shall effectively implement and maintain appropriate Best

- Management Practices (BMPs) shown in Table 1. In addition, the Permittee or Authorized Representative and their contractors shall comply with the following requirements:
 - Sediments shall not be discharged to the storm drain system or receiving waters. Sediments generated on the construction site shall be retained.
 - No construction-related materials: waste, spills, or residue shall be discharged from the project site to streets, drainage facilities, receiving waters, or adjacent property by wind or runoff.
 - Non-storm water runoff from equipment, vehicle washing, or any other activity shall be contained within the project site using appropriate BMPs.
 - Erosion from slopes and channels shall be prevented.
 - Minimize grading during the wet season (October 15 through April 15). All erosion susceptible slopes shall be covered, planted, or protected in any way that prevents sediment discharge from the project site.

BMPs shall conform to the requirements in the LACDPW Construction Division's "Construction Site Best Management Practices (BMPs) Manual," and addenda thereto issued up to and including, the date of issuance of the Permit for the project. Copies of the Manual are available for purchase from:

Los Angeles County Department of Public Works
Cashier's Office
900 South Fremont Avenue
Alhambra, CA 91803
Telephone (626) 458-6959

Year-Round Implementation Requirements

The Permittee or Authorized Representative and their contractors shall have an effective program for implementing, inspecting, and maintaining water pollution control practices for wind erosion control, tracking control, non-storm water control, and waste management and materials pollution control.

Soil stabilization and sediment control practices shall be provided throughout the rainy season, defined as between October 15 and April 15, and whenever the National Weather Service predicts rain within 24 hours. The National Weather Service weather forecast shall be monitored and used by the Permittee on a daily basis.

The non-rainy season shall be defined as all days outside the defined rainy season. Disturbed soil areas within the project shall be protected in conformance with the requirements in the Construction Site BMP Manual with sediment controls implemented prior to a predicted rain event.

Maintenance and Inspection

The Permittee or Authorized Representative and their contractors shall be responsible throughout the duration of the project for installing, constructing, inspecting, maintaining, removing and disposing of the BMPs. Unless otherwise directed by LACDPW, the Permittee or Authorized Representative and their contractors are responsible for BMP implementation and maintenance throughout any temporary suspension of work. The Permittee or Authorized Representative shall reimburse LACDPW for the full costs of cleaning or repairing of storm drain, water course, or channel which may be necessary due to ineffective implementation of BMPs.

The project site shall be inspected by the Permittee or Authorized Representative or their contractors a minimum of once every week or at least once for projects that last only one week or less.

Report of Non-Permitted Discharge and Enforcement

If the Permittee or Authorized Representative or their contractors identify any non-permitted discharge into the storm drain system or receiving waters in a manner causing, or potentially causing, a condition of pollution, or if the project receives a written notice or order from any regulatory agency, the Permittee or Authorized Representative or their contractors shall immediately inform LACDPW Construction Division Permits Section by calling the assigned Field Office. The Permittee or Authorized Representative or their contractors shall submit a written report (see attached Notice of Non-Permitted Discharge) to the LACDPW within 5 days of the discharge event, notice or order.

The Permittee or Authorized Representative and their contractors are subject to enforcement action by Chapter 12.80 of the Los Angeles County Code that states, *corporation, municipality or district or any officer or agent of any firm, corporation, municipality or district violating any provision of this chapter shall be guilty of a misdemeanor. Such violation shall be punishable by a fine of not more than \$1,000 or by imprisonment in the county jail for a period not to exceed six months, or by both fine and imprisonment. Each day during any portion of which such violation is committed, continued or permitted shall constitute a separate offense and shall be punishable as such (Ord. 98-0021§1(part), 1998).*

In addition, the Permittee or Authorized Representative and their contractors are subject to enforcement action by the State Water Resources Control Board (SWRCB), Environmental Protection Agency, private citizens and citizen groups. The Permittee or Authorized Representative and their contractors shall be responsible for the costs and for liabilities imposed

by law as a result of the Permittee or Authorized Representative or their contractor's failure to

comply. Costs and liabilities include, but are not limited to, fines, penalties and damages whether assessed against LACDPW or the Permittee or Authorized Representative or their contractors, including those levied under the Federal Clean Water Act and the State Porter Cologne Water Quality Act.

Table 1 Construction Site BMPs		
ID	BMP Name	Minimum Requirement⁽¹⁾
Temporary Soil Stabilization		
SS-1	Scheduling	X ⁽²⁾
SS-2	Preservation of Existing Vegetation	X ⁽²⁾
SS-3	Hydraulic Mulch ⁽³⁾	
SS-4	Hydroseeding ⁽³⁾	
SS-5	Soil Binders ⁽³⁾	
SS-6	Straw Mulch ⁽³⁾	
SS-7	Geotextiles, Plastic Covers, & Erosion Control Blankets/Mats ⁽³⁾	
SS-8	Wood Mulching	
SS-9	Earth Dikes/Drainage Swales & Ditches	
SS-10	Outlet Protection/Velocity Dissipation Devices	
SS-11	Slope Drains	
SS-12	Streambank Stabilization	
Temporary Sediment Control		
SC-1	Silt Fence ⁽⁴⁾	
SC-2	Desilting Basin	
SC-3	Sediment Trap	
SC-4	Check Dam	
SC-5	Fiber Rolls ⁽⁴⁾	
SC-6	Gravel Bag Berm ⁽⁴⁾	
SC-7	Street Sweeping and Vacuuming	X ⁽²⁾
SC-8	Sandbag Barrier ⁽⁴⁾	
SC-9	Straw Bale Barrier ⁽⁴⁾	
SC-10	Storm Drain Protection	X ⁽²⁾
Wind Erosion Control		
WE-1	Wind Erosion Control	X ⁽²⁾
Tracking Control		
TC-1	Stabilized Construction Entrance/Exit	
TC-2	Stabilized Construction Roadway	
TC-3	Entrance/Outlet Tire Wash	

Table 1 (continued) Construction Site BMPs		
ID	BMP Name	Minimum Requirement⁽¹⁾
Non-Storm Water Management		
NS-1	Water Conservation Practices	
NS-2	Dewatering Operations ⁽⁵⁾	
NS-3	Paving and Grinding Operations	
NS-4	Temporary Stream Crossing	
NS-5	Clear Water Diversion	
NS-6	Illicit Connection/Illegal Discharge Detection and Reporting	X ⁽²⁾
NS-7	Potable Water/Irrigation	
NS-8	Vehicle Equipment Cleaning	X ⁽²⁾
NS-9	Vehicle Equipment Fueling	X ⁽²⁾
NS-10	Vehicle Equipment Maintenance	X ⁽²⁾
NS-11	Pile Driving Operations	
NS-12	Concrete Curing	
NS-13	Material and Equipment Use Over Water	
NS-14	Concrete Finishing	
NS-15	Structure Demolition/Removal Over or Adjacent to Waters	
NS-16	Temporary Batch Plant	
Waste Management and Material Pollution Control		
WM-1	Material Delivery	X ⁽²⁾
WM-2	Material Use	X ⁽²⁾
WM-3	Stockpile Management	
WM-4	Spill Prevention and Control	X ⁽²⁾
WM-5	Solid Waste Management	X ⁽²⁾
WM-6	Hazardous Waste Management	
WM-7	Contaminated Soil Management	
WM-8	Concrete Waste Management	
WM-9	Sanitary/Septic Waste Management	X ⁽²⁾
WM-10	Liquid Waste Management	

- (1) Additional BMPs may be required based on actual field condition, Contractor operations, or construction operations.
- (2) Not all minimum requirements may be applicable to every project. Applicability to a specific project shall be verified by the Permittee or Authorized Representative and their Contractor.
- (3) The Permittee or Authorized Representative and their Contractors shall select one of the identified soil stabilization BMPs or a combination thereof.
- (4) The Permittee or Authorized Representative and their Contractors shall select one of the identified sediment control barrier BMPs or a combination thereof.
- (5) Dewatering BMPs are required for discharging accumulated precipitation (rain and snow melt) and for potential contact with groundwater during

APPENDIX G

LOS ANGELES COUNTY LIABILITY INSURANCE REQUIREMENTS

LIABILITY INSURANCE:

The Permittee shall furnish the Agency a certificate of liability insurance with the Agency named as certificate holder and a copy of the Additional Insured Endorsement to the general liability insurance of the permittee's contractor. Notwithstanding any inconsistent statement in the policy or any subsequent endorsement attached thereto, the Agency shall be named as an additional insured covering the work, whether liability is attributable to the Permittee or the Agency.

1. The Permittee may file insurance acceptable to the Agency covering more than one permit. The coverage shall provide the following minimum limits:

General Aggregate Limit.....	\$2,000,000
Other than Products/Completed Operations Aggregate	\$2,000,000
Products/Completed Operations Aggregate Limit	\$2,000,000
Personal Injury Limit.....	\$1,000,000
Each Occurrence.....	\$1,000,000

2. A combined single limit policy with aggregate limits in the amount of \$ 2,000,000 will be considered equivalent to the required minimum limits.
3. Workers' Compensation and Employers' Liability insurance in an amount and form to meet all applicable requirements of the Labor Code of the State of California, which includes Employers' Liability coverage with limits of not less than \$1,000,000 per accident and which specifically covers the persons and risks involved in this Permit. Permittee understands and agrees that all persons furnishing services pursuant to this Permit are, for purposes of Workers' Compensation liability, employees solely of Permittee and not of County. Permittee shall bear the sole responsibility and liability for furnishing Workers' Compensation benefits to any person for injuries arising from or connected with services performed on behalf of Permittee pursuant to the Permit. The insurance company shall have a policy rating equal to or better than that of the California State Compensation Insurance Fund (SCIF).
4. Automobile Liability insurance with limits of not less than \$1,000,000 for bodily injury and property damage, in combined or equivalent split limits, for each single accident. Insurance shall cover liability arising out of Permittee's use of autos pursuant to the permit, including owned, leased, hired, and/or non-owned autos, as each may be applicable.

The Policy or Policies shall be endorsed to provide that the insurer waives all rights of subrogation against the Agency, and its respective elected officials, officers, employees, agents, and representatives for losses paid under the terms of the policy or policies and which arise from work performed by the named insured pursuant to this permit.

All liability insurance policies shall bear an endorsement or shall have attached rider whereby it is provided that, in the event of expiration or proposed cancellation of such policies for any reason whatsoever, the Agency shall be notified by mail, giving a sufficient time before the date thereof to comply with any applicable law or statute, but in no event less than 30 days before expiration or cancellation is effective.

The Additional Insured Endorsement to the general liability insurance must contain the following language:

"The County of Los Angeles and public entity or Special District for which the Los Angeles County Board of Supervisors is the Governing Body, and their Agents, Officers and Employees."

NOTE: Circled items MUST be filled out completely.

ACORDTM CERTIFICATE OF LIABILITY INSURANCE

DATE (MM/DD/YYYY)
01/01/2013

PRODUCER
INSURANCE BROKER OR COMPANY NAME AND CONTACT INFORMATION, INCLUDING EMAIL ADDRESS

THIS CERTIFICATE IS ISSUED AS A MATTER OF INFORMATION ONLY AND CONFERS NO RIGHTS UPON THE CERTIFICATE HOLDER. THIS CERTIFICATE DOES NOT AMEND, EXTEND OR ALTER THE COVERAGE AFFORDED BY THE POLICIES BELOW.

INSURED
COMPANY NAME AND CONTACT INFORMATION, INCLUDING A VALID EMAIL ADDRESS

INSURERS AFFORDING COVERAGE	NAIC #
INSURER A:	
INSURER B:	
INSURER C:	
INSURER D:	
INSURER E:	

COVERAGES

THE POLICIES OF INSURANCE LISTED BELOW HAVE BEEN ISSUED TO THE INSURED NAMED ABOVE FOR THE POLICY PERIOD INDICATED. NOTWITHSTANDING ANY REQUIREMENT, TERM OR CONDITION OF ANY CONTRACT OR OTHER DOCUMENT WITH RESPECT TO WHICH THIS CERTIFICATE MAY BE ISSUED OR MAY PERTAIN, THE INSURANCE AFFORDED BY THE POLICIES DESCRIBED HEREIN IS SUBJECT TO ALL THE TERMS, EXCLUSIONS AND CONDITIONS OF SUCH POLICIES. AGGREGATE LIMITS SHOWN MAY HAVE BEEN REDUCED BY PAID CLAIMS.

INSR LTR	ADD'L INSRD	TYPE OF INSURANCE	POLICY NUMBER	POLICY EFFECTIVE DATE (MM/DD/YY)	POLICY EXPIRATION DATE (MM/DD/YY)	LIMITS
		GENERAL LIABILITY <input checked="" type="checkbox"/> COMMERCIAL GENERAL LIABILITY <input type="checkbox"/> CLAIMS MADE <input checked="" type="checkbox"/> OCCUR GEN'L AGGREGATE LIMIT APPLIES PER: <input type="checkbox"/> POLICY <input type="checkbox"/> PRO-JECT <input checked="" type="checkbox"/> LOC	GL8050623	08/01/12	08/01/13	EACH OCCURRENCE \$ 1,000,000 DAMAGE TO RENTED PREMISES (Ea occurrence) \$ 500,000 MED EXP (Any one person) \$ 10,000 PERSONAL & ADV INJURY \$ 1,000,000 GENERAL AGGREGATE \$ 2,000,000 PRODUCTS - COMP/OP AGG \$ 2,000,000
		AUTOMOBILE LIABILITY <input type="checkbox"/> ANY AUTO <input checked="" type="checkbox"/> ALL OWNED AUTOS <input type="checkbox"/> SCHEDULED AUTOS <input checked="" type="checkbox"/> HIRED AUTOS <input checked="" type="checkbox"/> NON-OWNED AUTOS	TP988035201	08/01/12	08/01/13	COMBINED SINGLE LIMIT (Ea accident) \$ 1,000,000 BODILY INJURY (Per person) \$ BODILY INJURY (Per accident) \$ PROPERTY DAMAGE (Per accident) \$
		GARAGE LIABILITY <input type="checkbox"/> ANY AUTO				AUTO ONLY - EA ACCIDENT \$ OTHER THAN AUTO ONLY: EA ACC AGG \$
		EXCESS/UMBRELLA LIABILITY <input checked="" type="checkbox"/> OCCUR <input type="checkbox"/> CLAIMS MADE DEDUCTIBLE \$ RETENTION \$	006502599	08/01/12	08/01/13	EACH OCCURRENCE \$ 2,000,000 AGGREGATE \$ 2,000,000
		WORKERS COMPENSATION AND EMPLOYERS' LIABILITY ANY PROPRIETOR/PARTNER/EXECUTIVE OFFICER/MEMBER EXCLUDED? Yes / No If yes, describe under SPECIAL PROVISIONS below OTHER	FACRUB3175M68411	08/01/12	08/01/13	WC STATU-TORY LIMITS OTH-ER E.L. EACH ACCIDENT \$ 1,000,000 E.L. DISEASE - EA EMPLOYEE \$ 1,000,000 E.L. DISEASE - POLICY LIMIT \$ 1,000,000

All policy expirations MUST be valid until after permit expiration date

DESCRIPTION OF OPERATIONS / LOCATIONS / VEHICLES / EXCLUSIONS ADDED BY ENDORSEMENT / SPECIAL PROVISIONS

CERTIFICATE HOLDER

COUNTY OF LOS ANGELES
DEPARTMENT OF PUBLIC WORKS
LAND DEVELOPMENT DIVISION
P. O. BOX 1460
ALHAMBRA, CA 91802-1460
ATTENTION: _____

CANCELLATION

SHOULD ANY OF THE ABOVE DESCRIBED POLICIES BE CANCELLED BEFORE THE EXPIRATION DATE THEREOF, THE ISSUING INSURER SHALL MAIL 30 DAYS WRITTEN NOTICE TO THE CERTIFICATE HOLDER.

AUTHORIZED REPRESENTATIVE

MUST match with General Liability Policy Number on Certificate of Liability Insurance

POLICY NUMBER: _____

**COMMERCIAL GENERAL LIABILITY
CG 20 12 05 09**

THIS ENDORSEMENT CHANGES THE POLICY. PLEASE READ IT CAREFULLY.

**ADDITIONAL INSURED – STATE OR GOVERNMENTAL
AGENCY OR SUBDIVISION OR POLITICAL
SUBDIVISION – PERMITS OR AUTHORIZATIONS**

This endorsement modifies insurance provided under the following:

COMMERCIAL GENERAL LIABILITY COVERAGE PART

SCHEDULE

MUST include this section verbatim

State Or Governmental Agency Or Subdivision Or Political Subdivision:

The County of Los Angeles and public entity or Special District for which the Los Angeles County Board of Supervisors is the Governing Body, and their Agents, Officers and Employees.

Information required to complete this Schedule, if not shown above, will be shown in the Declarations.

Section II – Who Is An Insured is amended to include as an insured any state or governmental agency or subdivision or political subdivision shown in the Schedule, subject to the following provisions:

1. This insurance applies only with respect to operations performed by you or on your behalf for which the state or governmental agency or subdivision or political subdivision has issued a permit or authorization.

2. This insurance does not apply to:

- a. "Bodily injury", "property damage" or "personal and advertising injury" arising out of operations performed for the federal government, state or municipality; or
- b. "Bodily injury" or "property damage" included within the "products-completed operations hazard".

APPENDIX H

EXCEL BRIDGE ERECTING INSTRUCTIONS



BRIDGE MANUFACTURING CO.

www.excelbridge.com

12001 Shoemaker Ave
Santa Fe Springs CA 90670
(800) 548-0054
Fax (562) 944-4025

LIST OF TOOLS

suggested for bridge installation, in addition to the usual rigging.

NOTE! your most important tool is your phone:

- **At time of order and during fabrication, the customer should keep Excel abreast of the latest expected installation date. You must call Excel at least two weeks before the delivery date to confirm.** Coordination of the delivery is as much the contractors responsibility as it is Excel's. There are variables on both sides like weather, construction problems, right-of-way permits, material shortages, special truck trailer type coordination, over sized shipment permits, shipping curfews, etc. The telephone is your most important installation tool. Call Excel with your questions early and often.
- Excel Shop Drawings that were approved for fabrication. **READ** the installation instructions and notes on the drawings. If your project has a concrete deck, the re-bar design will be indicated in the notes or on the drawings.
- Wrenches for anchor bolt nuts
- Timbers
- lever bar
- Grease
- **If your project has a splice(s), you may need:**
- AISC manual which includes turn-of-the-nut method instructions
- Hand winches to pull splices together for spliced bridges
- Large tapered pins, wedges and lever bars
- Paint, crayon or scribe to mark bolt heads for spliced bridges
- Hammer and long chisel to remove nubs sometimes found on bolt holes inside tubes on spliced bridges
- If your project is painted: Straps instead of chains, and brushes etc. for touch up work
- If your project has a wood deck, a few deck planks must sometime be shipped loose at the splice area. To install them you may need: A drill with correct size bits, possibly a counter sink, and possibly a star driver for your drill. Wrenches will be needed for the nuts & bolts on these loose planks. If self tapping bolts are used, pay very close attention to drilling the correct sized holes in the correct order. Warning, if your project has an Ironwood® deck, this hard wood will shear bolts off if over tightened or if the drilled hole is too small.
- If your project comes with a concrete form pan, check the shop drawings for the method of attaching the loose sheets at the splice point, if any.

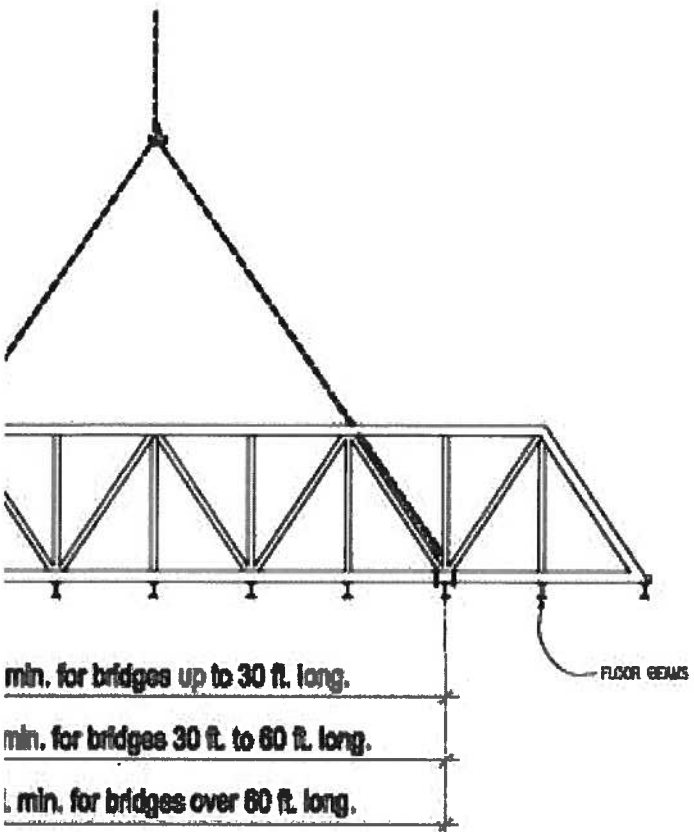

of thumb - attach strap or chain
of span length from each end.

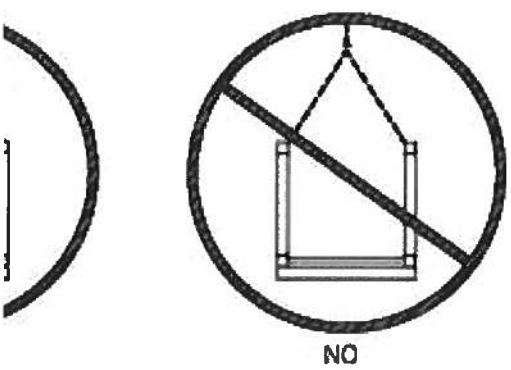

ERECTION PROCEDURE

- Run chain or cable through truss web and around floor beams at no more than 30' from each end. (See sketch matching your bridge type).
- Return chain or cable immediately inside truss and bring to one central point above center of bridge. **CAUTION: Chain or cable should not contact railing system or top chord.**
- Swing bridge into place and stop approximately 6" above bridge seat. "Clip" one mount plate over each corner of bridge.
- Set bridge making sure mount plates slide over anchor bolts.
- Install and tighten nuts on anchor bolts per instructions on your approved drawings.
- For bridge weight, see approval drawing.
- Depending on crane size, longer bridges may require two cranes.
- Bridge placement is to be performed by qualified crane operators and riggers only. Excel Bridge Mfg. is not responsible for damage and/or injury during bridge erection.

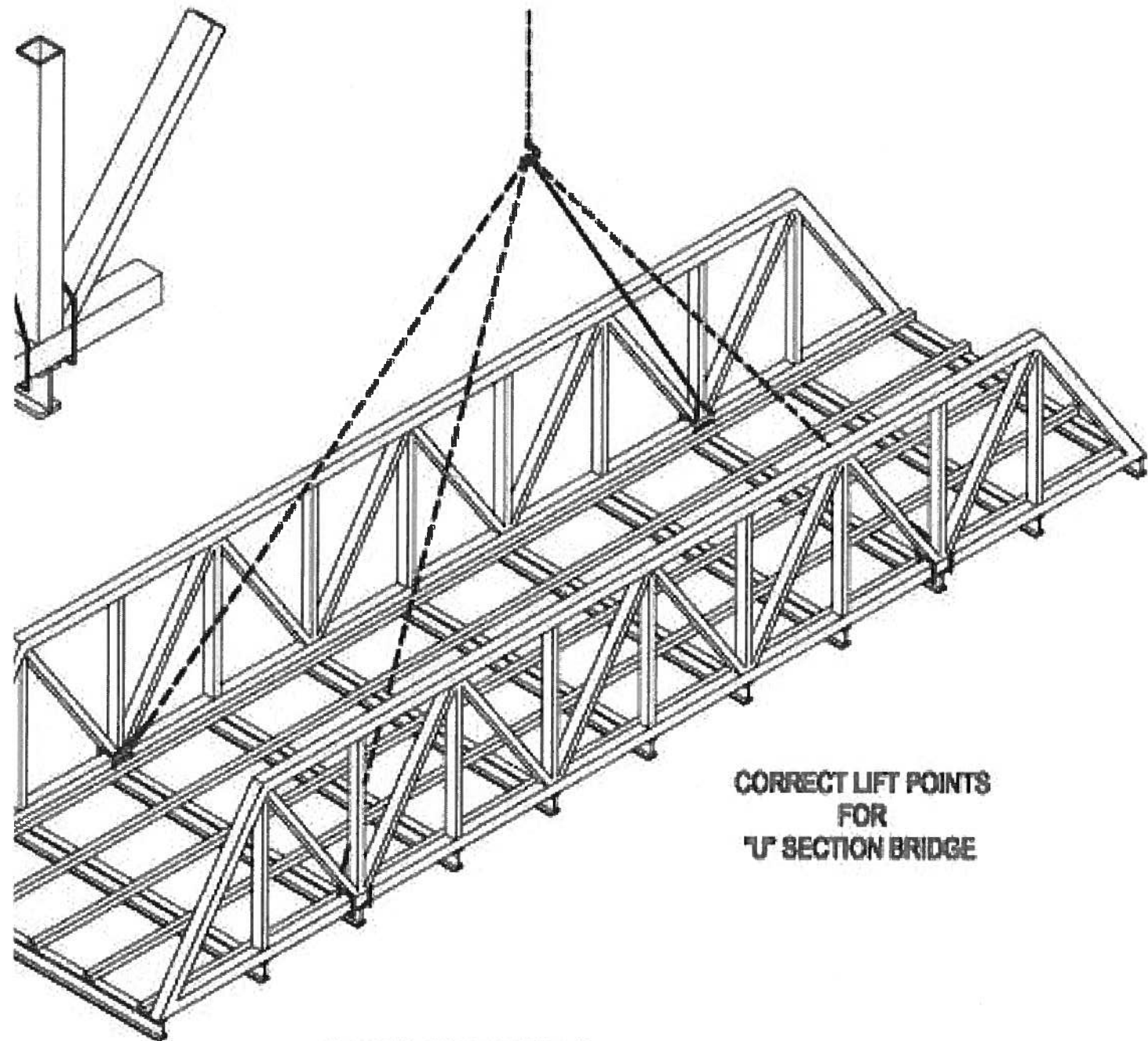

**CORRECT LIFT POINTS
FOR
"U" SECTION BRIDGE**

"U" SECTION BRIDGE

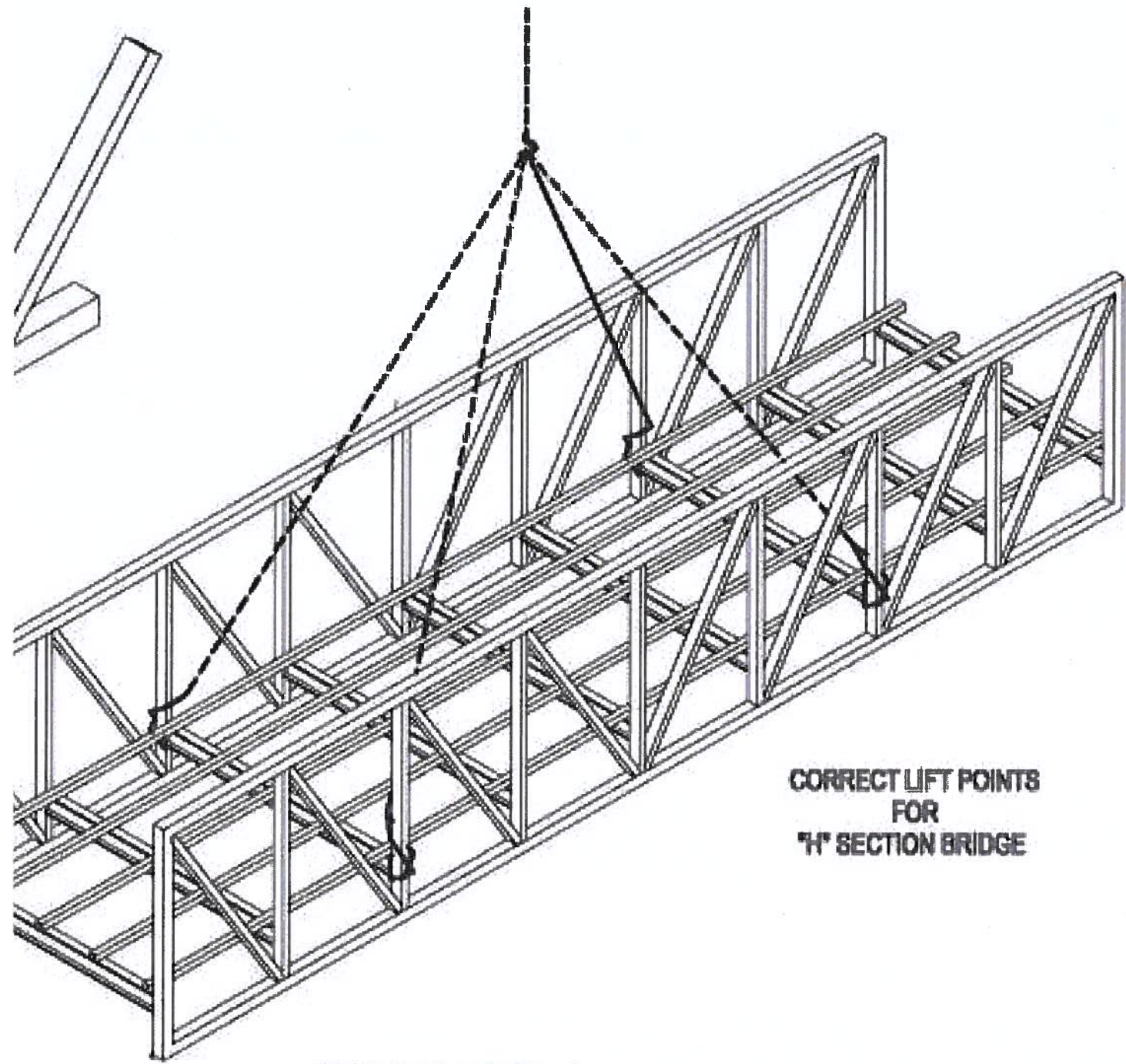

**CORRECT LIFT POINTS
FOR
"H" SECTION BRIDGE**

"H" SECTION BRIDGE

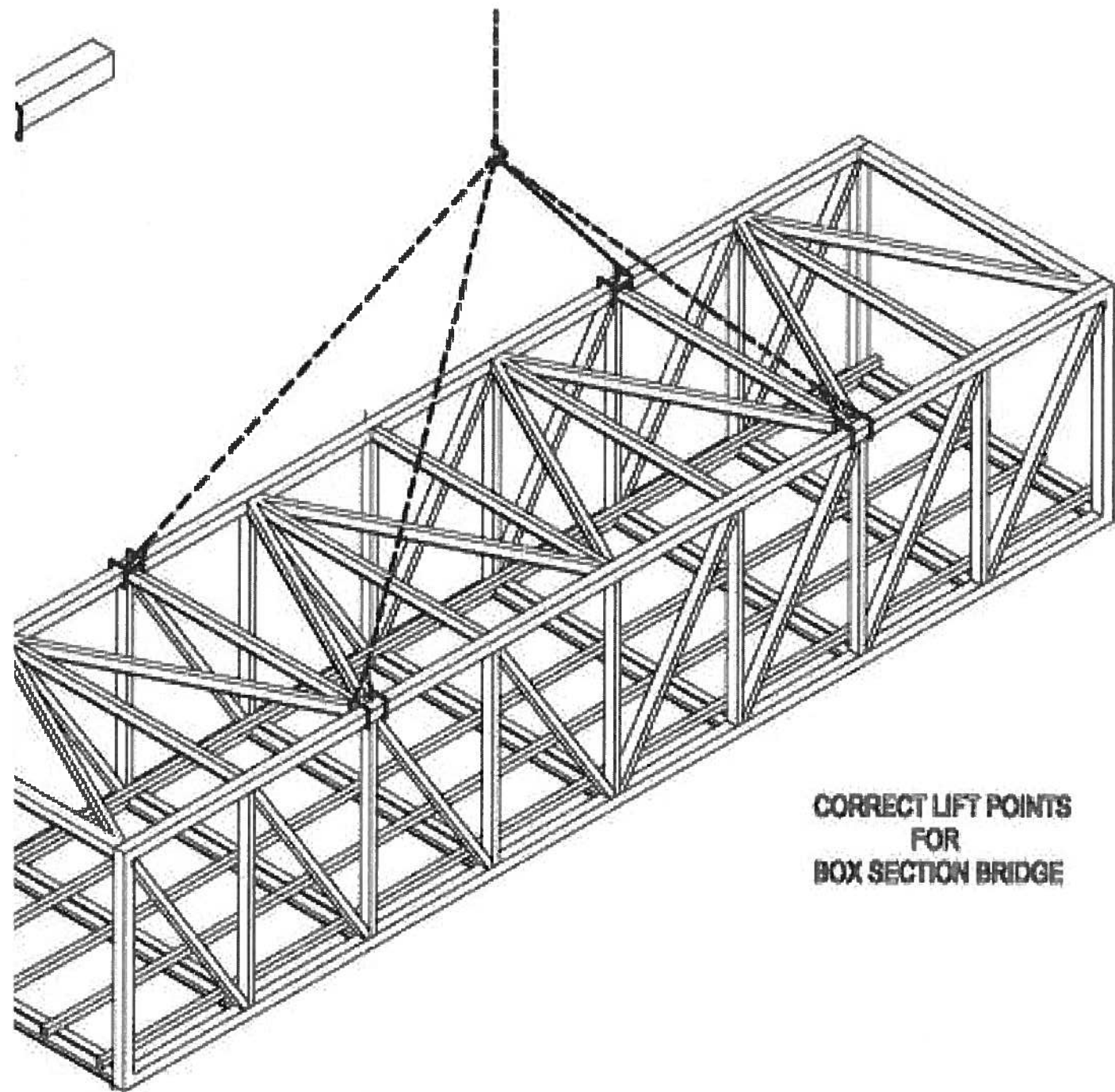

**CORRECT LIFT POINTS
FOR
BOX SECTION BRIDGE**

BOX SECTION BRIDGE

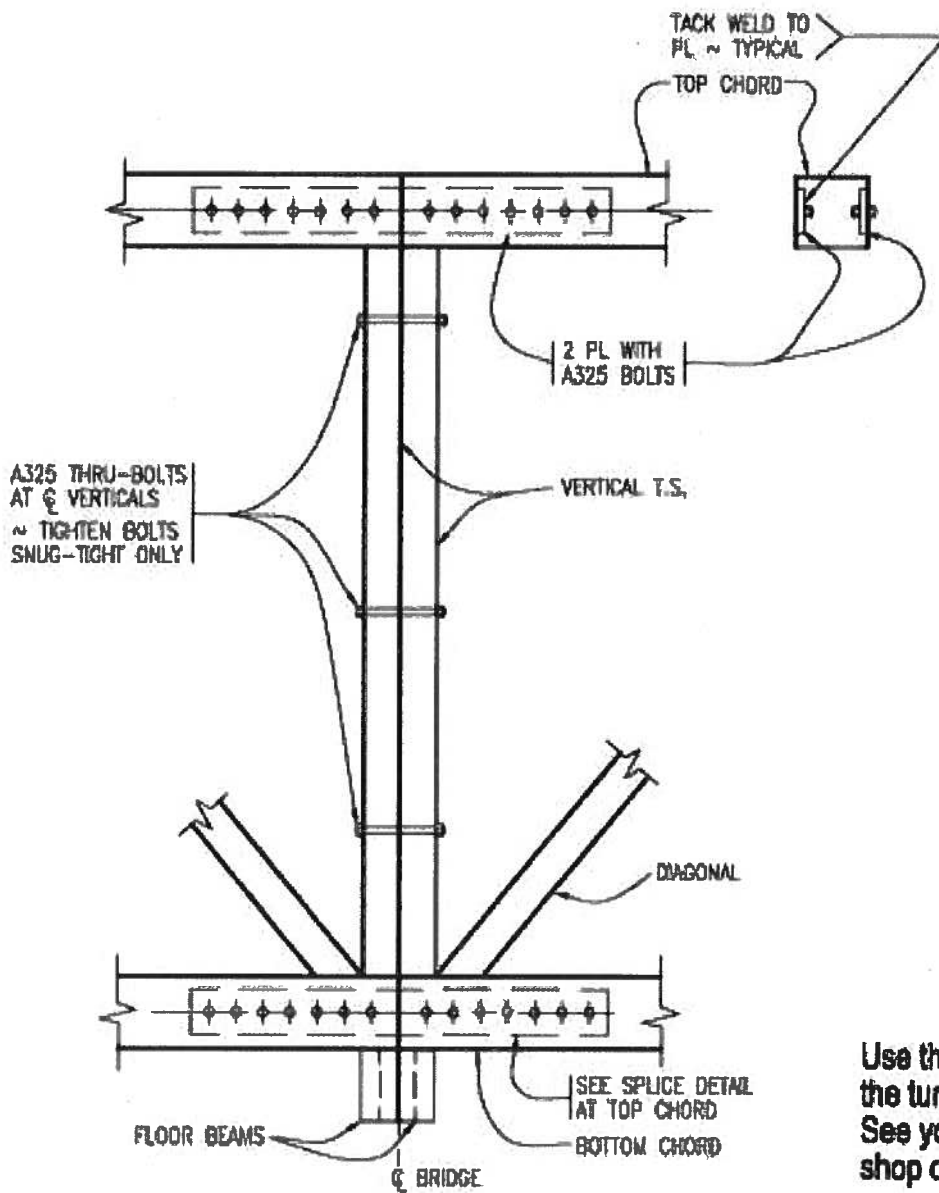

Use the AISC manual following the turn-of-the-nut method. See your Excel "approved" shop drawings for instruction.

TYPICAL SPLICE DETAIL

nd
j"

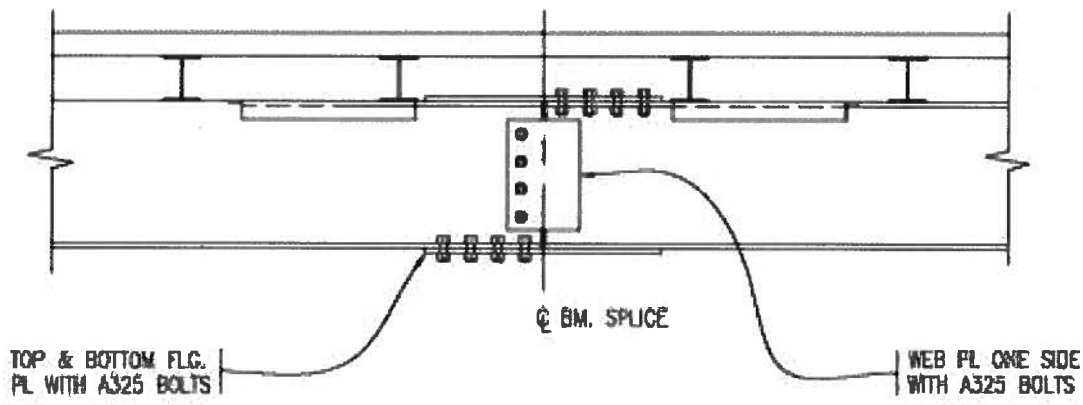

TYPICAL FLOOR BEAM - SPLICE

(COMMON ONLY WITH BRIDGE DECKS OVER 14' WIDE)