

FOOTING/BUILDING SETBACKS FROM SLOPES

IH-08

4-15-22

The placement of buildings and structures on or adjacent to slopes steeper than 3 horizontal to 1 vertical shall be in accordance with Section 1808.7 of the California Building Code (CBC) and Section R403.1.7 of the California Residential Code (CRC). When a geology and/or soils report is required by the Department, the setbacks prescribed by the code shall be considered sufficient only when the report has addressed the following:

1. The static, seismic (when required), and surficial stability of the slope. The factor of safety must meet a minimum of 1.5 for static and 1.0 for seismic.
2. The kinematic stability (when required) of rock slopes. The factor of safety must meet a minimum of 1.5 for potential planar, wedge, and/or topple failures where the kinematic analyses have demonstrated the geometric potential of such failure modes to occur.
3. The erosion potential of the soils. Appropriate mitigation measures must be provided as necessary.
4. The adequate performance of similar slopes in the general area.
5. Appropriate surface water drainage provisions.
6. Debris/mudflow potential.

Figures 1 through 8 show standard methods of providing the code required setback for buildings and footings for all structures except pools.

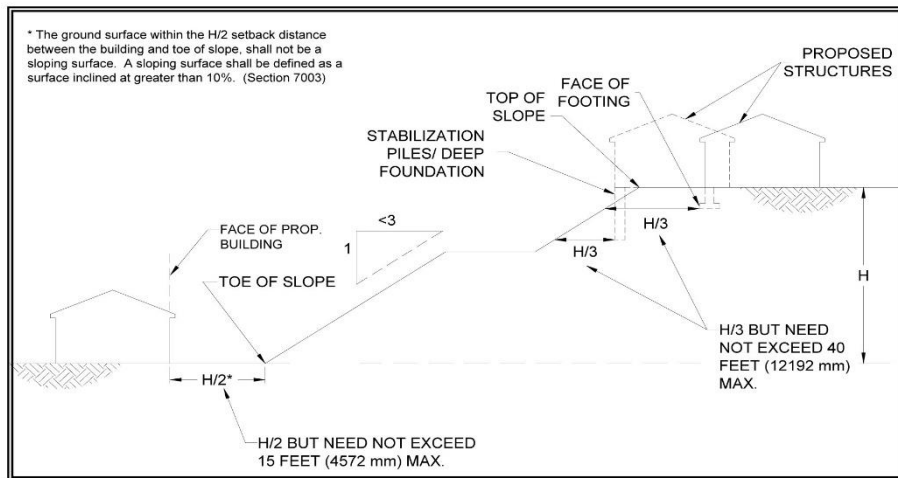

Figure 1 (Section 1808.7.1 & R403.1.7.1)

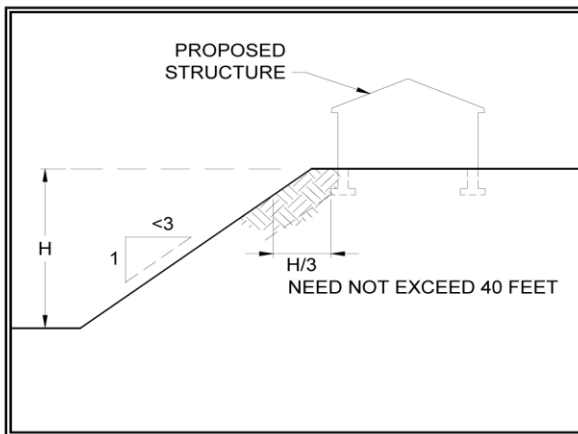

Figure 2 (Sections 1808.7.2 & R403.1.7.2)

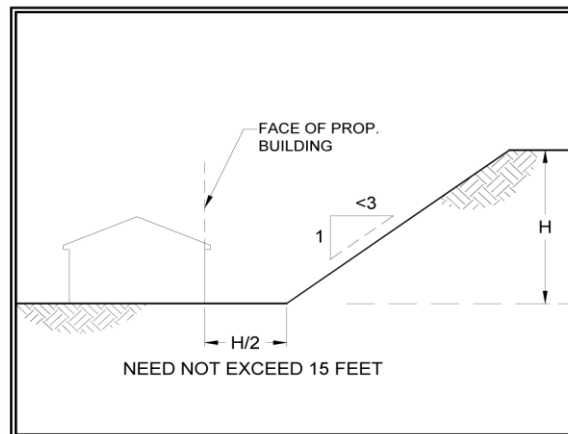

Figure 3 (Sections 1808.7.1 & R403.1.7.1)

FOOTING/BUILDING SETBACKS FROM SLOPES

IH-08

4-15-22

Where the slope is steeper than 1:1 (45 degrees), then the setback is measured from an imaginary line projected at an angle of 45 degrees and tangent to the slope (see Figures 4 & 5).

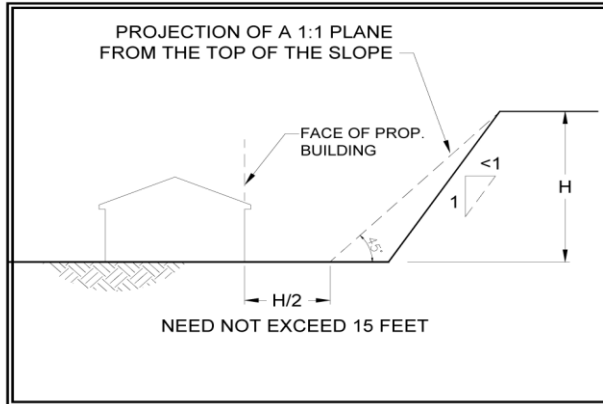

Figure 4 (Sections 1808.7.1 & R403.1.7.1)

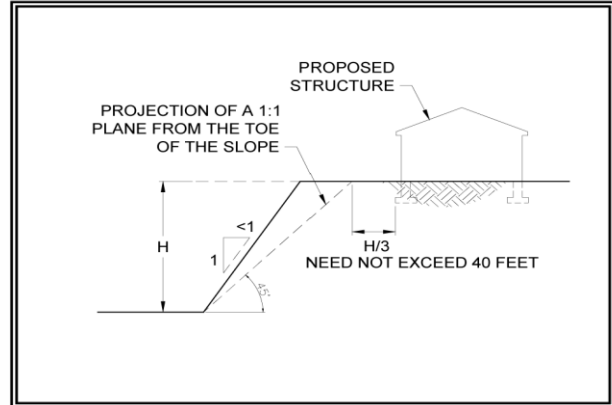

Figure 5 (Sections 1808.7.2 & R403.1.7.2)

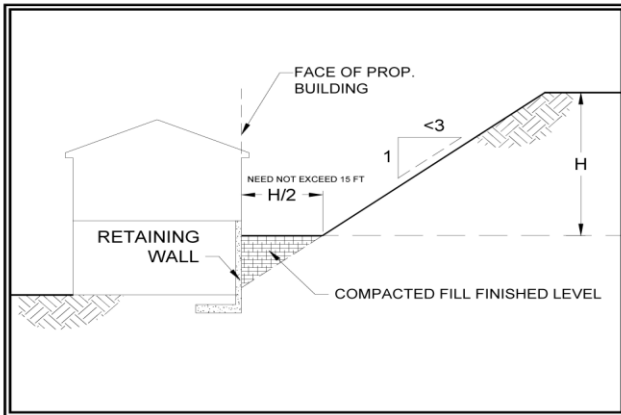

Figure 6 (Sections 1808.7.1 & R403.1.7.1)

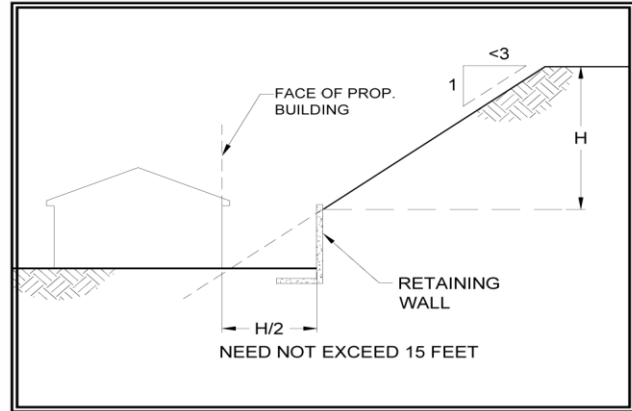

Figure 7 (Sections 1808.7.1 & R403.1.7.1)

The H/2 level setback may be partitioned into a maximum of two adjoining levels by the use of retaining walls, such that when the two levels are added together they equal the distance H/2 (as shown in Figure 8). Where the H/2 distance is less than or equal to 5 feet, only one level is allowed.

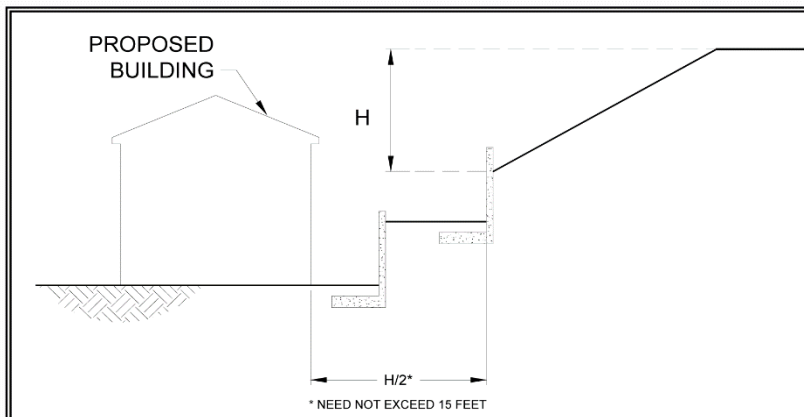

Figure 8 (Sections 1808.7.1 & R403.1.7.1)

As shown in Figures 6, 7, and 8, the building shall be provided with a level setback area from the ascending slope. The toe of the slope shall not be located against the building wall.

FOOTING/BUILDING SETBACKS FROM SLOPES

IH-08

4-15-22

POOL SETBACKS

Figures 9, 10, 11, and 12 show how the standard setback can be provided for pools adjacent to a slope steeper than 3 horizontal to 1 vertical but less than 1 horizontal to 1 vertical. Where the slope is steeper than 1:1, the setback shall be measured from an imaginary plane projected at an angle of 45 degrees and tangent to the slope. In addition to the footing setback, any portion of the pool wall within 7 feet of the top of the slope shall be designed for a freestanding condition, without soil support (see Figure 10).

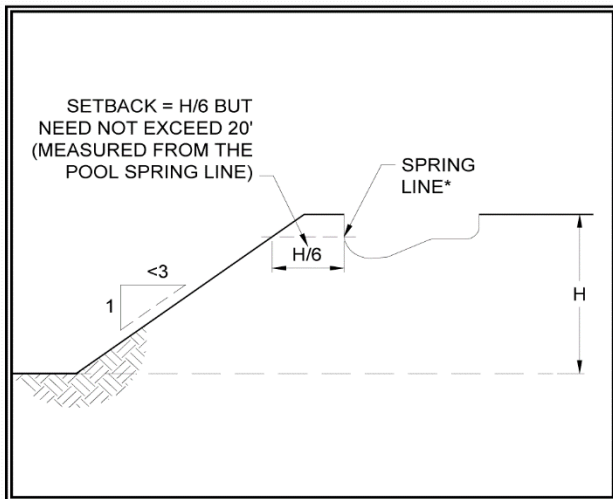

Figure 9 (Section 1808.7.3)

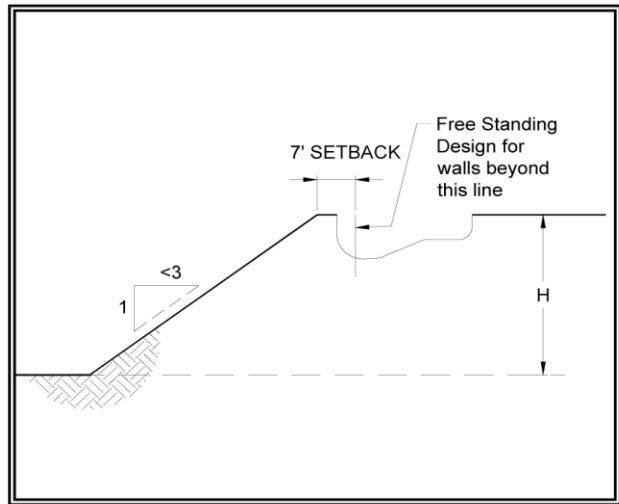

Figure 10 (Section 1808.7.3)

* The spring line is defined as the location on the pool shell where it changes curvature away from the adjacent slope. In addition, the pool clearance dimension is measured to the outside of the pool shell, not the inside finished surface.

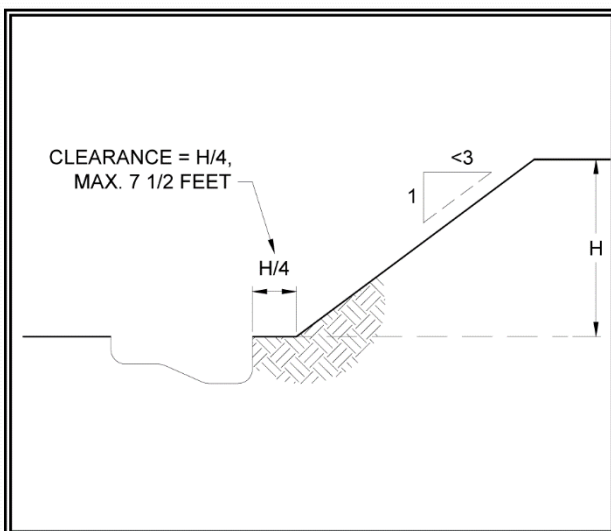

Figure 11 (Section 1808.7.3)

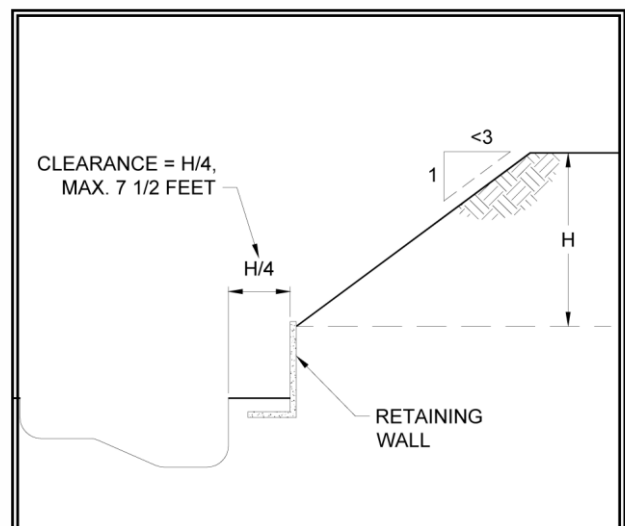

Figure 12 (Section 1808.7.3)