

## REPORT TO CITY COUNCIL

**DATE:** NOVEMBER 9, 2022

**TO:** HONORABLE MAYOR AND MEMBERS OF THE CITY COUNCIL

**FROM:** NATHAN HAMBURGER, CITY MANAGER

**BY:** DENICE THOMAS, AICP, COMMUNITY DEVELOPMENT DIRECTOR  
LUKAS QUACH, BUILDING OFFICIAL

**SUBJECT:** ADOPTION OF AN ORDINANCE OF THE CITY COUNCIL OF THE CITY OF AGOURA HILLS, STATE OF CALIFORNIA, ADOPTING BY REFERENCE THE 2022 EDITION OF THE CALIFORNIA BUILDING STANDARDS CODE COMPRISED OF THE 2022 EDITIONS OF THE ADMINISTRATIVE, BUILDING, RESIDENTIAL, ELECTRICAL, MECHANICAL, PLUMBING, ENERGY, HISTORICAL BUILDING, FIRE, EXISTING BUILDING, GREEN BUILDING STANDARDS, AND REFERENCED STANDARDS CODES, AND ADOPT A RESOLUTION MAKING FINDINGS THAT AMENDMENTS TO THE 2022 EDITIONS OF THE CALIFORNIA BUILDING, RESIDENTIAL, PLUMBING, FIRE, EXISTING BUILDING, AND GREEN BUILDING STANDARDS CODES, AS ADOPTED ARE REASONABLY NECESSARY BECAUSE OF LOCAL CLIMATIC, GEOLOGICAL, OR TOPOGRAPHICAL CONDITIONS

---

Every three years, the State of California adopts a new set of model codes to establish uniform standards for the construction and alteration of buildings, electrical systems, plumbing systems, mechanical systems, and fire and life safety systems. The California Building Standards Commission, in early 2022, adopted the Triennial 2022 Edition of the California Code of Regulations, Title 24, consisting of the Administrative Code, Building Code, Residential Code, Electrical Code, Mechanical Code, Plumbing Code, Energy Code, Historical Building Code, Fire Code, Existing Building Code, Green Building Standards Code, and Reference Standards Code, also known collectively as the 2022 California Building Standards Code. All jurisdictions in California are required to adopt the California Building Standards Code (California Codes).

The 2022 California Building Standard Code will go into effect statewide on January 1, 2023, and will be in effect in all jurisdictions in California as of that date, whether adopted by local jurisdictions or not. Local jurisdictions may adopt amended versions of the California Codes, but only if they are stricter than the base California Codes and such amendments are subsequently approved by the California Building Standards Commission. The State Building Standards Code provides the minimum construction

standards. Under state law, local jurisdictions are permitted to make amendments to the State Code if there are local conditions that make it reasonably necessary because of local climatic, geological, or topographical conditions.

The Building and Safety Division is proposing amendments to some building standards in the California Building, Residential, Plumbing, and California Green Building Standards (CALGreen) Codes. The amendments will affect the construction standards of new buildings, additions, and alterations to existing buildings and with the exception of the seismic earthquake valve provision, are generally not retroactive to existing buildings.

Administrative amendments are modifications to the Building Codes that do not establish building standards and may be enacted without having to provide justification to the State with express findings based on local climatic, geological, or topographical conditions. They are amended to facilitate the City's operation relating to civil, administrative, or criminal procedures for carrying out and enforcing building standards.

Below are some of the highlights of the proposed amendments to the Building Codes:

- **Administrative Amendments.** The majority of the “proposed” administrative amendments are carried over from the previous code cycle, such as extending plan check and permit expirations to 12 months; providing criteria for plan check and permit extension and refund; and imposing a penalty for doing work without a permit. Most of the new proposed administrative amendments are associated with the administration of the grading provisions of Appendix J.
- **Los Angeles Regional Uniform Code Program (LARUCP) Recommended Amendments.** LARUCP's recommended amendments are mostly structurally-related with specific provisions for hillside structures and shipping containers. Seismic provision for Hillside structures is proposed to be added to the Code to better mitigate and limit property damage that is the result of increased seismic forces which are imparted upon hillside buildings and structures. The proposed amendment relating to Intermodal Shipping Containers is to assist Building and Safety staff with a prescriptive path to ensure minimum design and safety standards associated with the repurposing of existing intermodal shipping containers as buildings or structures.
- **Grading and Drainage.** With the adoption of Appendix J of the California Building Code and its proposed amendments, the City will have the guidelines and technical provisions to enforce grading requirements.
- **Voluntary Seismic Retrofit.** Staff is proposing that the earthquake mitigation standards in Appendix A of the 2022 California Existing Building Code be adopted as a voluntary measure to provide guidelines for upgrading the seismic-resistance capacity of different types of existing deficient buildings.
- **Automatic Gas Shut-off Valves.** To reduce potential fire and explosion hazards,

an amendment to the California Plumbing Code is proposed requiring the installation of earthquake gas shut-off valves for new construction, remodel/addition with a valuation greater than \$10,000, and when the property is being sold.

- **Very High Fire Hazard Severity Zone (VHFHSZ) Construction Standard for all of Agoura Hills.** The amendment reflects the City's desire to enforce the same construction standards throughout the City as it is required for the structures located in the VHFHSZ, without designating the entire City in this fire zone.
- **Appendix P – Emergency Housing.** Adopting this Appendix will provide a framework for Agoura Hills to deal with housing needs in natural disasters such as major seismic events and fire events.
- **Appendix AQ – Tiny Houses.** The adoption of Appendix AQ would provide the framework for Building and Safety staff to review tiny houses in accordance with established standards in the event that tiny houses are allowed in the City.

In addition to the changes to the Building Codes, there are also amendments proposed for the Municipal Code. They include:

- **Reorganization of Chapters 1 and 2 of Article VIII.** Staff recommends a reorganization, to be more aligned with the conventional Building Code structure. Each Subchapter containing building standard provisions is relocated to its corresponding Building Code.
- **2021 International Property Maintenance Code (IPMC).** The adoption of the 2021 IPMC establishes minimum requirements to provide a reasonable level of health, safety, property protection, and general welfare for its occupants and the public.
- **Re-adoption of Expedited Review of Small Residential Rooftop Solar Energy System Permits (Ordinance No. 15-418) and Expedited Review of Electric Vehicle Charging Station Permits (Ordinance No. 17-431).** These two sections were, inadvertently, removed from the Municipal Code during the 2019 triennial building code adoption, which became effective on January 1, 2020. For this Code adoption cycle, staff is proposing to address the oversight and incorporate the content of the ordinances back into the Agoura Hills Municipal Code.

### **Introduction of Ordinance 22-465.**

At its meeting on October 12, 2022, the City Council (by a vote of 5-0) introduced an Ordinance adopting the various California State Codes referenced above, with certain local amendments, as detailed in the attached proposed Ordinance. The proposed

Ordinance amends certain listed subchapters and chapters of the Agoura Hills Municipal Code and incorporates the contents into the various State Codes as local amendments.

At the aforementioned meeting, the City Council expressed reservations about the trigger for allowing the use of emergency homes. In addressing the City Council's concern about the unintended use of emergency housing, if not authorized by the City Council, Staff amended Section AZ103.1 in the CRC Appendix AZ and Section P103.1 in the CBC Appendix P by adding a provision to the trigger that requires specific authorization by the City of Agoura Hills City Council. The language was amended and reviewed by the City Attorney and approved as to form.

The City Council also requested clarity on whether modified shipping containers and tiny houses are allowed in the City from the land use perspective. The zoning ordinance, as adopted, does not preclude the use of tiny houses and shipping containers modified for residential uses. Section 9675 of the Agoura Hills Municipal Code states, "The mobile home permit is established to provide the individual placement of a mobile home containing one dwelling unit, in lieu of a single-family residence, on a lot or parcel of land where permitted in the district [(RV, RL, RS, RM, and RH (Section 9284.1 Agoura Hills Municipal Code))], subject to the area requirements of the land use district. It is the intent of this permit to recognize the modern mobile home as an alternate source of affordable factory-built housing available from the manufacturer with an exterior similar to conventionally constructed housing. The mobile home permit is intended to ensure that mobile homes so placed are compatible with surrounding uses, that the proposed site is suitable, and that the property values are protected through the imposition of appropriate regulations and conditions for placement and maintenance of such mobile homes. These provisions do not apply to mobile home parks." These provisions were adopted before other alternate housing options were widely used and approved by HCD.

Section 9252.4 (J) of the Agoura Hills Municipal Code states, in pertinent part, "manufactured homes (mobile homes) on a permanent foundation, as a single-family dwelling, subject to the provisions of Section 9675, if more than ten (10) years have elapsed between the date of manufacture of the manufactured home and the date of the application for the issuance of a permit to install the manufactured home" may be permitted with a conditional use permit. While the code calls out mobile homes, this provision would apply to other types of manufactured homes approved by the California Department of Housing and Community Development (HCD) as well, subject to the design requirements contained in Section 9284.1(A – I) of the Agoura Hills Municipal Code.

Based on the preceding information, the Zoning Ordinance, as adopted, provides alternatives to traditional housing types. Amending the Building Codes to include provisions for review of shipping containers and tiny houses will allow staff to review said projects. Inclusion of provisions to evaluate containers allows the review of containers that are modified for human habitation in a prescriptive way as well. The



provisions are knowable to the designer of such housing, as well as, staff reviewing the projects. Without the Building Codes amendment, costly analyses will have to be undertaken by property owners to ensure compliance. The Certified Housing Element contains policies that ensure that legislative constraints to the production of houses are curtailed. Amending the Building Code to include prescriptive standards that reduce or eliminate the need for costly technical reports furthers the goal and policy of eliminating constraints.

At its meeting of October 12, 2022, the City Council introduced, read by title only, and waived further reading of Ordinance No. 22-465, and set the Public Hearing for the adoption of the Building Code Ordinance for Wednesday, November 9, 2022. This evening staff brings the proposed Ordinance, along with a Resolution making express findings that the state code amendments are reasonably necessary because of local climatic, geological, or topographical conditions, to the City Council for adoption. If the City Council adopts the Ordinance, then the most recent editions of the above-referenced Building Codes, with local amendments, will be in effect on January 1, 2023.

## **RECOMMENDATION**

Staff respectfully recommends the City Council adopt Ordinance No. 22-465 and Resolution No. 22-2024 making expressed findings that the state code amendments are reasonably necessary because of local climatic, geological, or topographical conditions

Attachment: Ordinance No. 22-465  
Resolution No. 22-2024

## ORDINANCE NO. 22-465

**AN ORDINANCE OF THE CITY COUNCIL OF THE CITY OF AGOURA HILLS, STATE OF CALIFORNIA, ADOPTING BY REFERENCE THE 2022 EDITION OF THE CALIFORNIA BUILDING STANDARDS CODE COMPRISED OF THE 2022 EDITIONS OF THE ADMINISTRATIVE, BUILDING, RESIDENTIAL, ELECTRICAL, MECHANICAL, PLUMBING, ENERGY, HISTORICAL BUILDING, FIRE, EXISTING BUILDING, GREEN BUILDING STANDARDS, AND REFERENCED STANDARDS CODES, AND THE 2021 EDITION OF THE INTERNATIONAL PROPERTY MAINTENANCE CODE, AND AMENDING ARTICLES III and VIII OF THE AGOURA HILLS MUNICIPAL CODE**

**WHEREAS**, it is the desire and intent of the City Council of the Agoura Hills to provide citizens with the greatest degree of structural, fire and life safety in buildings in the most cost-effective manner by adopting that body of regulations referred to as the California Building Standards Code with amendments specific to the City of Agoura Hills; and

**WHEREAS**, the City Council has determined that the provisions of the California Building Standards Code shall be adopted as modified, changed, and amended, as provided for in this ordinance, based upon the specific findings, and that said Council takes said action in order to more fully preserve and protect the public health, safety, welfare, and property.

**NOW, THEREFORE, THE CITY COUNCIL OF THE CITY OF AGOURA HILLS HEREBY ORDAINS AS FOLLOWS:**

**SECTION 1.** Chapters 1 and 2 of Article VIII of the Agoura Hills Municipal Code are hereby repealed; provided, however, that such repeal shall not affect or excuse any violation of any of said codes occurring prior to the effective date of this ordinance.

**SECTION 2.** Sections 3100 and 3101 of Chapter 1 (Fire Prevention) of Article III (Public Safety) of the Agoura Hills Municipal Code are hereby amended to read as follows:

**“3100. Adoption of California Fire Code, 2022 Edition.**

Pursuant to California Government Code §§ 50022.1 to 50022.8, the California Fire Code (“CFC”), 2022 Edition, published as Title 24, Part 9, of the California Code of Regulations is adopted by reference, subject to the amendments, additions, and deletions set forth below.

One true copy of the CFC is on file in the office of the Building Official and is available for public inspection as required by law.

**3101. Modifications to the 2022 California Fire Code.**

a) Section 101.1 is amended to read as follows:

**101.1 Title.** These regulations shall be known as the Fire Code of *the City of Agoura Hills*, hereinafter referred to as “this code”.

b) Section 103.1 is amended to read as follows:

**103.1 General.** *The office of fire prevention is established within the jurisdiction under the direction of the fire code official for the implementation, administration and enforcement of the provisions of this code*

**Exception:** *For the enforcement of the sprinkler systems for one- or two-family dwellings and the townhouses, the Building Official or the Fire Official, at the discretion of the City Manager shall be the responsible authority having jurisdiction.*

c) Section 903.2.8 is amended to read as follows:

**903.2.8 Group R.** An automatic sprinkler system installed in accordance with Section 903.3 shall be provided throughout all buildings with a Group R fire area.

*Fire sprinkler systems shall be installed in mobile homes, manufactured homes and multifamily manufactured homes with two dwelling units in accordance with Title 25 of the California Code of Regulations.*

Exceptions:

1. Existing Group R-3 occupancies converted to Group R-3.1 occupancies not housing bedridden clients, not housing non-ambulatory clients above the first floor, and not housing clients above the second floor.
2. Existing Group R-3 occupancies converted to Group R-3.1 occupancies housing only one bedridden client and complying with Section 435.8.3.3 of the California Building Code.
3. Pursuant to Health and Safety Code, Section 13113, occupancies housing ambulatory children only, none of whom are mentally ill children or children with intellectual disabilities, and the buildings or portions thereof in which such children are housed are not more than two stories in height, and buildings or portions thereof housing such children have an automatic fire alarm system activated by approved smoke detectors.
4. Pursuant to Health and Safety Code, Section 13143.6, occupancies licensed for protective social care which house ambulatory clients only, none of whom is a child (under the age of 18 years), or who is elderly (65 years of age or over).

When not used in accordance with area or height increases for automatic fire sprinklers allowed in the California Building Code, an automatic sprinkler system installed in accordance with Section 903.3.1.2 shall be allowed in Group R-2.1 occupancies.

An automatic sprinkler system designed in accordance with Section 903.3.1.3 shall not be utilized in Group R-2.1 or R-4 occupancies.

d) Section 903.2.11 is amended to read as follows:

**903.2.11 - Specific buildings areas and hazards.** In all occupancies other than Group U, an automatic sprinkler system shall be installed for building design or hazards in the locations set forth in Sections 903.2.11.1 through 903.2.11.7.

e) Section 903.2.11.7 is added to read as follows:

**903.2.11.7 - Occupancies in fire hazard severity zones and within the Malibu-Santa Monica Mountains or San Gabriel South-face Areas.** *An automatic fire sprinkler system shall be installed in every occupancy which is newly constructed or which is modified, reconstructed, or remodeled by adding 50 percent or more of the floor area of the existing occupancy, within any 12-month period, where the occupancy is located in a fire hazard severity zone and within the Malibu-Santa Monica Mountains or the San Gabriel Mountains South-face Areas, as defined in Appendix P of the Los Angeles County Fire Code.*

*Exceptions:*

- 1. Occupancies located in the San Gabriel Mountains Southface Areas and which are located three miles or less from the closest existing or planned Los Angeles County Fire Station capable of supporting firefighting resources are exempt from the fire sprinkler requirement. Travel distances shall be measured by the most direct route on streets or roads accessible to fire department apparatus.*
- 2. Occupancies modified, reconstructed, or remodeled by adding 50 percent or more of the floor area of the existing occupancy, where the total floor area of the occupancy after the modification, reconstruction, or remodel is less than 5,000 square feet, are exempt from the fire sprinkler requirement.*
- 3. Detached private garages, sheds, and agricultural buildings less than 200 square feet (19 m<sup>2</sup>) in area and separated from other structures by a minimum of six feet, are exempt from the fire sprinkler requirement.*
- 4. Detached gazebos, pergolas, and carports open on two or more sides, that are separated from other structures by a minimum of six feet are exempt from the fire sprinkler requirement.*

5. *Detached U occupancies, separated from other structures by a minimum of six feet (1829 mm), built entirely out of non-combustible materials, and with no combustible storage, are exempt from the fire sprinkler requirement.*

*For the purposes of this subsection, "planned Los Angeles County Fire Station" means a fire station, approved by the Consolidated Fire Protection District of Los Angeles County that will be developed within five years from the date of building permit application for the subject development.*

**SECTION 3.** New Chapters 1 (Administration) and 2 (Construction Codes) are hereby added to Article VIII (Building Regulations) of the Agoura Hills Municipal Code to read as follows:

**"Chapter 1 ADMINISTRATION**

- 8100. Adoption of codes.
- 8101. Building official designated.
- 8102. Administration of adopted codes.
- 8103. Violations and Penalties

**Chapter 2 CONSTRUCTION CODES**

- 8200. Reserved.
- 8201. California Administrative Code
- 8202. California Building Code with local amendments.
- 8202.5. California Residential Code with local amendments.
- 8203. California Electrical Code with local amendments.
- 8204. California Mechanical Code with local amendments.
- 8205. California Plumbing Code with local amendments.
- 8206. California Energy Code with local amendments.
- 8207. Reserved.
- 8208. California Historical Building Code with local amendments.
- 8209. Reserved.
- 8210. California Existing Building Code with local amendments.
- 8211. California Green Building Standards Code with local amendments.
- 8212. California Referenced Standards Code with local amendments.
- 8213. Reserved.
- 8214. Reserved.
- 8215. Reserved.
- 8216. Expedited Review of Small Residential Rooftop Solar Energy System Permits.
- 8217. Expedited Review of Electric Vehicle Charging Station Permits
- 8218. Reserved.
- 8219. Reserved.

## **Chapter 1—ADMINISTRATION**

### **8100. Adoption of Codes.**

For the purpose of prescribing regulations for erecting, construction, enlargement, alteration, repair, improving, removal, conversion, demolition, occupancy, equipment use, height and area of buildings and structures in the City, the 2022 editions of the California Administrative Code, Building Code, Residential Code, Electrical Code, Mechanical Code, Plumbing Code, Energy Code, Historical Building Code, Fire Code, Green Building Standards Code, Existing Building Code, and Referenced Standards Code, collectively comprising the California Building Standards Code, are hereby adopted by reference, with certain amendments, as the Building Regulations of the City of Agoura Hills. For the purpose of prescribing regulations for grading and excavations, Appendix “J” of the California Building Code with amendments is adopted and will continue to be enforced.

### **8101. Building official designated.**

The Building Official is hereby designated as the authority charged with the administration and enforcement of Article VIII of the Agoura Hills Municipal Code with the exception of Appendix “J” of the California Building Code, which will be enforced by the Director of Public Works or his/her designee. Where the “authority having jurisdiction” is used in the adopted codes, it shall mean the Building Official.

### **8102. Administration of adopted codes.**

Except as specified in this Article, the administration and enforcement of Article VIII shall be in accordance with the Administration Chapter of the California Building Code as adopted in Section 8100 and amended in Section 8201 and Section 8202.

### **8103. Violations and Penalties.**

In addition to any other applicable provision of this Article VIII, any person, firm, partnership, association, corporation or joint venture violating any of the provisions of Article VIII shall be guilty of a misdemeanor.

## **Chapter 2—CONSTRUCTION CODES**

### **8200. Reserved.**

### **8201. California Administrative Code adopted.**

The 2022 Edition of the California Administrative Code, published by the International Code Council, and all amendments, supplements and errata thereto, is hereby adopted by reference and shall be applicable to the City of Agoura Hills, and referred to as the “Administrative Code of the City of Agoura Hills.”

One copy of the California Administrative Code of the City of Agoura Hills shall be kept on file in the Building Official's office for public inspection.

## **8202. California Building Code Adopted with Local Amendments**

### A. Adoption of California Building Code, 2022 Edition.

Pursuant to California Government Code Section 50022.2, the California Building Code, 2022 Edition, published as Title 24, Part 2, of the California Code of Regulations, including Chapter 7A (Materials and Construction Methods for Exterior Wildfire Exposure), Appendix P (Emergency Housing), and Appendix J (Grading) and all supplements and errata thereto (collectively "CBC"), is adopted by reference, subject to the amendments, additions and deletions set forth below.

One true copy of the CBC is on file in the office of the Building Official and is available for public inspection as required by law.

### B. Amendments to the 2022 California Building Code.

a) The second paragraph of Section 1.8.8.1 is amended to read as follows:

*The City Council shall serve as the local appeals board or housing appeals board as specified in California Health and Safety Code Sections 17920.5 and 17920.6.*

b) Section 1.8.8.4 is added to read as follows:

**1.8.8.4 Limitation of Authority.** *The Local Appeals Board and the Housing Appeals Board shall not have jurisdiction to consider, decide or rule on whether persons are responsible or not responsible for violations and public nuisances of the Agoura Hills Municipal Code, as well as on actions that are required by the City of responsible persons to correct or otherwise abate violations and/or public nuisances.*

*This limitation of authority shall also apply to any board that is established by the 2022 Residential, Electrical, Mechanical, Plumbing, Energy, Fire, Existing Building and Green Building Standards Codes, as adopted by the City.*

c) Section 101.1 is amended to read as follows:

**101.1 Title.** These regulations shall be known as the Building Code of *the City of Agoura Hills*, hereinafter referred to as "this code".

d) Section 101.4.1 is amended to read as follows:

**101.4.1 Gas.** The provisions of California Mechanical and *California Plumbing Code* shall apply to the installation of gas piping from the point of delivery, gas appliances and related accessories as covered in this code. These requirements apply to gas

pipng systems extending from the point of delivery to the inlet connections of appliances and the installation and operation of residential and commercial gas appliances and related accessories.

e) Section 101.4.5 is amended to read as follows:

**101.4.5. Fire Prevention.** The provisions of the *Los Angeles County Fire Code* shall apply to matters affecting or relating to structures, processes and premises from the hazard of fire and explosion arising from the storage, handling or use of structures, materials or device; from conditions hazardous to life, property or public welfare in the occupancy of structures or premises; and from the construction, extension, repair, alteration or removal of fire suppression, automatic sprinkler systems and alarm systems or fire hazards in the structure or on the premises from occupancy or operation.

f) Section 103.3 is amended to read as follows:

**103.3 Deputies.** In accordance with the prescribed procedures of this jurisdiction and with the concurrence of the appointing authority, the building official shall have the authority to appoint a deputy building official, *the* related technical officers, inspectors, *plan examiners*, and other employees. Such employees shall have powers as delegated by the building official.

g) Section 105.1 is amended to read as follows:

**105.1 Required.** *All persons who intend to construct, enlarge, alter, move, demolish or change the occupancy of a building or structure, or to erect, install, enlarge, alter, repair, remove, convert or replace any electrical, gas, mechanical or plumbing system, component or device, the installation of which is regulated by the Technical Codes in Article VIII of the Agoura Hills Municipal Code, shall first make written application to the building official and obtain each required permit. Parking lots shall not be paved, improved, striped, or restriped unless a separate permit for each parking lot has first been obtained from the building official.*

*No person shall undertake or cause grading to occur on land without the prior procurement of a grading permit unless such grading is exempt from a permit as provided for in Section 103.2 of Appendix J.*

*Whenever any work or installation or grading has been commenced without a permit in violation of this section, a Stop Work Order shall immediately be issued by the Building Official and a special investigation to identify the nature and extent of the unpermitted work or installation shall be made. Based on the findings of the investigation, conditions may be given to the violator to correct any unpermitted conditions to the satisfaction of the Building Official and/or the City Engineer prior to the issuance of the permit and to continue work. An investigation fee shall be paid in addition to customary fees for each permit which the work had started prior to, or at*



*the time of, the issuance of a permit or permits. Failure to pay a special investigation fee in full constitutes cause to deny the issuance of a permit or permits. The investigation fee shall be as specified by resolution of the City Council.*

*The payment of the investigation fee shall not exempt any person from compliance with all other provisions of the Agoura Hills Municipal Code, or from any penalty prescribed by law for failing to obtain each required permit.*

- h) Section 105.2, under **Building** - items 1 through 13 are amended, and items 14 thru 18 are added; under **Electrical** - items 4 and 5 are added, and a new category titled **Grading** is added, to read as follows:

**Building:**

1. One-story detached accessory structures used as tool and storage sheds, *shade structure, playhouses or similar uses that are accessory to detached one and two family dwellings, and similar uses*, provided the floor area does not exceed 120 square feet *and are not more than 14 feet in height above adjacent grade*. It is permissible that these structures still be regulated by Section 710A, despite exemption from permit.
2. Fences, *other than masonry or concrete, not over 6 feet high, measured from finished grade immediately adjacent to the fence, to top of the finished fence.*
3. Oil derricks.
4. Retaining walls *or masonry/concrete fence wall, less than 2 feet in height measured from grade immediately adjacent to the wall to the top of the wall, and not supporting a surcharge.*
5. Water tanks supported directly on grade if the capacity is not greater than 5000 gallons and the ratio of height to diameter or width is not greater than 2:1.
6. Sidewalks, driveways, *platforms and walkways associated with one and two family dwellings*, not more than 30 inches above grade *at any point* and not located over any basement or story below, *nor supporting any structure above and are not part of an accessible route.*
7. Painting, papering, tiling, carpeting, cabinets, counter tops and similar finish work.
8. Temporary motion picture, television and theater stage sets and scenery *structures that are erected and maintained for a specific period of time in connection with a filming permit that is issued pursuant to Article VI, Chapter 6 of the Agoura Hills Municipal Code. Electrical installations (including the use*

*of generators) and gas installations for sets and structures require a permit before they occur.*

9. Prefabricated swimming pool accessory to a Group R-3 Occupancy that are less than 18 inches deep, do not exceed 5,000 gallons and are installed entirely above ground.
10. Shade cloth structures constructed for nursery or agricultural purposes, not including service systems.
11. Swings and other playground equipment accessory to detached one- and two-family dwellings.
12. Window awnings supported by an exterior wall in group R-3 and U occupancies, that are less than 12 square feet of shade cover and do not project more than 48 inches from exterior wall and do not require additional support.
13. Non-fixed and movable fixtures, cases, racks, counters and partitions not over 5 feet 9 inches in height.
14. Detached one story shade covers for animals when the covers are not over 12 feet in height above adjacent grade, not more than 400 feet of roof area and open on 3 sides minimum.
15. Readily removable plastic covered hoop structures, with maximum 12' in height with no in-ground footings or foundation.
16. Replacement of residential exterior door when the door frame is not removed.
17. Replacement of kitchen appliance with similar appliance in same location. This exception does not apply if the work includes opening the walls or replacing or altering the plumbing or electrical systems.
18. Flagpoles that are 20 feet or less in height above finish grade when fully extended.

**Electrical:**

...

4. Removal of abandoned electrical wiring and conduits. "Abandoned" means such wiring and conduits that are not energized.
5. Low voltage electric wiring/system (under 25 volt or 50 watts).

**Grading:**

1. All grading that is exempt from a permit shall be pursuant to Section 103.2 of Appendix "J" of this code or other reference codes accepted by the Building Official.

i) Section 105.3.2 is amended to read as follows:

**105.3.2 Time Limitation of Application.** *Unless extended or reinstated as provided herein, an application for permit is deemed abandoned if an applicant has not satisfied all requirements for a permit for proposed work or actions within twelve (12) months of tender of an application to the Building and Safety Division. The Building Official is authorized to grant one or more extensions of time for additional periods not exceeding ninety (90) days each to complete all requirements for a permit. An applicant seeking an initial extension shall tender a request to the Building Official prior to the date the application is deemed abandoned. In order to be eligible for any further extensions, an applicant shall tender a subsequent request or requests to the Building Official before a prior extension period expires. Each extension request shall be requested in writing and justifiable cause demonstrated, as determined by the Building Official.*

*When an application has been deemed abandoned, a permit shall not be issued prior to the application being reinstated or a new application tendered with new fees paid. Requests to reinstate an application that has been deemed abandoned shall be submitted to the Building Official, in writing, demonstrating justifiable cause and are subject to the approval of the Building Official. If approved by the Building Official, the fee shall be one half (1/2) of the amount of the original plan review fee, provided that the period of time following the Building Official's date of determination of abandonment of the original application has not exceeded six (6) months, no changes have been made or will be made in the original submittal and the construction codes under which the original application was submitted are the same as the current construction codes in effect. To reinstate a application when the period of time following the Building Official's date of determination of abandonment of the original application has exceeded six (6) months; or changes have been made or will be made in the original submittal; or current construction codes are different from those construction codes under which the original application was submitted, the permittee shall be required to pay a new full permit fee and that person shall comply with all construction codes in effect on the date of the new permit application.*

j) Section 105.3.2.1 is added to read as follows:

**105.3.2.1 Time limitation of application in connection with an unpermitted structure.** *Unless extended or reinstated as provided herein, an application for a permit is deemed abandoned if an applicant has not satisfied all requirements for a permit in connection with an unpermitted structure as defined in Section 111.1.1 of this code within ninety (90) calendar days of tender of an application therefor to the Building and Safety Division. The Building Official is authorized to grant one or more extensions of time for additional periods not exceeding thirty (30) days each to*

*complete all requirements for a permit. An applicant seeking an initial extension shall tender a request to the Building Official prior to the date the application is deemed abandoned. In order to be eligible for any further extensions, an applicant shall tender a subsequent request or requests to the Building Official before a prior extension period expires. Each extension request shall be requested in writing and justifiable cause demonstrated, as determined by the Building Official.*

k) Section 105.5 is amended to read as follows:

**105.5 Expiration of permit.** *Unless extended or reinstated as provided herein, every permit issued, except those under Subsection 105.5.2, shall be deemed suspended or abandoned and shall automatically expire and become null and void unless the permittee completes at least twenty percent (20%) of the total work or actions authorized by a permit (as determined by the Building Official) for Group R-3 Occupancies, and at least ten percent (10%) of the total work or actions authorized by a permit (as determined by the Building Official) for all other occupancies, and the permittee obtains a successful inspection from the Building Official within the first twelve (12) months from the permit's issuance date. An issued permit shall also be deemed suspended or abandoned and shall automatically expire and become null and void if the permittee does not complete at least an additional twenty percent (20%) of the total work or actions authorized by a permit (as determined by the Building Official) for Group R-3 Occupancies, and at least an additional ten percent (10%) of the total work or actions authorized by a permit (as determined by the Building Official) for all other occupancies, and the permittee obtains a subsequent successful inspection within twelve (12) months from a prior successful inspection. A successful inspection is defined as an inspection that is required by Section 110 of Chapter 1, Division II of the 2022 California Building Code (as adopted by Section 8100 of the Agoura Hills Municipal Code), during which the Building Official or a designee thereof determined that the inspected work or actions met all applicable minimum code requirements and he/she approved and documented that work as successful. Notwithstanding prior timely successful inspections, a permit shall automatically expire and become null and void if the permittee does not obtain a final inspection approval from a building inspector for completion of all work or actions authorized by a permit as follows: (i) within three (3) years from the date of issuance of a permit having a valuation of less than \$250,000.00; (ii) within four (4) years from the date of issuance of a permit having a valuation of between \$250,000.00 and \$1,000,000.00; and, (iii) within five (5) years from the date of issuance of a permit having a valuation of more than \$1,000,000.00.*

*The Building Official may grant one (1) extension of a permit for a period not exceeding one hundred eighty (180) days, provided he/she receives a written request stating justifiable cause, prior to the expiration date of a permit. The Building Official may deny the request for a permit extension if her/she determines that justifiable cause was not shown in the request.*

*When a permit that was issued pursuant to Section 105.1 has expired, work shall not recommence prior to obtaining a new permit, which shall be subject to Section 105.5.2 of this code. Requests to reinstate an expired permit shall be submitted to the building official, in writing, demonstrating justifiable cause and are subject to the approval of the building official. If approved by the Building Official, the fee shall be one half (1/2) of the amount of the original permit fee, provided that the expiration period of the original permit has not exceeded six (6) months, no changes have been made or will be made in the original approved plans and specifications, and the construction codes under which the original permit was issued are the same as the current construction codes in effect. To reinstate a permit when the expiration period of the original permit has exceeded six (6) months; or changes have been made or will be made in the original approved plans and specifications; or current construction codes are different from those construction codes under which the original permit was issued the permittee shall be required to pay a new full permit fee and that person shall comply with all construction codes in effect on the date of the new permit application.*

- l) Section 105.5.1 is amended to read as follows:

**105.5.1 Expiration.** *Every permit issued before January 1, 2019 that did not automatically expire and become null and void by December 31, 2022 pursuant to the code then in effect shall be deemed abandoned and shall automatically expire and be null and void if the permittee does not thereafter obtain a subsequent successful inspection within 180 days from a prior successful inspection. A successful inspection is defined as an inspection that is required by Section 110 of Chapter 1, Division II of the 2022 California Building Code (as adopted by Section 8100 of the Agoura Hills Municipal Code), during which the Building Official or a designee thereof determined that the inspected work or actions met all applicable minimum code requirements and he/she approved and documented that work as successful. The Building Official may grant one extension of a permit subject to this subsection for a period not exceeding 180 days, provided he/she receives a written request stating justifiable case, prior to the expiration date of the permit. The Building Official may deny the request for a permit extension if her/she determines that justifiable cause was not shown in the request.*

*When a permit subject to this subsection has expired, work shall not recommence prior to obtaining a new permit, which shall be subject to Section 105.5.2 of this code. Payment of a full permit fee is required.*

- m) Section 105.5.2 is added to read as follows:

**105.5.2 Expiration of permit in connection with an unpermitted structure.** *Notwithstanding Section 105.5 or any other provision of this code to the contrary, if a permit is issued in order to bring an unpermitted structure (as defined in Section 111.1.1 of this code) or other unlawful condition into compliance with any applicable law, or ordinance, such permit shall automatically expire and become null and void ninety (90) calendar days after the date on which the permit was issued. The Building*

*Official may extend the validity of the permit for a period not exceeding ninety (90) calendar days beyond the initial ninety (90) day limit upon written request by the applicant filed with the Building Official prior to the expiration date of the original permit.*

n) Section 105.6 is amended to read as follows:

**105.6 Suspension or revocation.** *The Building Official is authorized to suspend or revoke a permit issued under the provisions of this code or other relevant laws, ordinances, rules, or regulations, wherever and whenever the permit is issued in error or on the basis of incorrect, inaccurate or incomplete information, or in violation of any ordinance or regulations or any of the provisions of this code.*

*The Building Official may also withhold inspections or approvals or suspend or revoke permit, where work is being performed in violation of approved plans, conditions of approval or permit, or applicable laws, and/or where work is being done not in accordance with the direction of the Building Official or this code.*

*The Building Official is authorized to suspend or revoke a permit if he/she, or a designee thereof, determines work is occurring in connection therewith between the hours of 7:00 p.m. and 7:00 a.m., Monday through Saturday and any time on Federal Holidays, which results in violations of the noise regulations located in Article 9, Chapter 6, Part 2, Division 6 of the Agoura Hills Municipal Code, and the permittee has not received prior written permission from the city manager to create such noise at that time.*

*The building official is authorized to suspend or revoke a permit issued under the provisions of this code if dust is generated in excess of local, state or federal standards or conditions of project approval.*

o) Section 105.7 is amended to read as follows:

**105.7 Placement of permit.** *The building permit or copy shall be kept on the site of the work until completion of the project. Required permits and approved plans shall be maintained in good condition and be posted or otherwise made available at job site such as to allow the building official to conveniently make the required review, inspection and entries related to the project.*

p) Section 105.8 is added to read as follows:

**105.8 Responsibility of permittee.** *It shall be the duty of every person who performs work for the installation or repair of building, structure, electrical, gas, mechanical or plumbing systems, for which this code is applicable, to comply with this code. Building permits shall be presumed by the City to incorporate all of the work that the applicant, the applicant's agent, employees and/or contractors shall carry out. Said proposed work shall be in accordance with the approved plans and with all requirements of this*

*code and any other laws or regulations applicable thereto. No city approval shall relieve or exonerate any person from the responsibility of complying with the provisions of this code nor shall any vested rights be created for any work performed in violation of this code.*

q) Section 105.9 is added to read as follows:

**105.9 Transferability.** *No permit issued pursuant to Article VIII of the Agoura Hills Municipal Code shall be transferable to any other person or apply to any location other than that stated in the permit, unless justifiable cause is demonstrated to the satisfaction of the Building Official and approved in writing*

r) Section 109.4 is amended to read as follows:

**109.4 Work commencing before permit issuance.** *Any person who commences any work for which a permit is required by this code before obtaining the necessary permits shall be subject to a special investigation by the Building Official before a permit may be issued for such work. An investigation fee, in addition to the permit fee, shall be collected whether or not a permit is then or subsequently issued. The investigation fee shall be equal to the amount of the permit fee required for such work by this code, or as identified in the latest fees adopted by the City Council of the City of Agoura Hills.*

s) Section 109.5.1 is added to read as follows:

**109.5.1 Re-inspection Fee.** *A re-inspection fee may be assessed for each inspection or re-inspection when such portion of work for which inspection is called is not complete or when corrections previously called for are not made. This section is not to be interpreted as requiring re-inspection fees the first time a job is rejected for failure to comply with the requirements of this code, but as controlling the practice of calling for inspections before the job is ready for such inspection or re-inspection.*

*Re-inspection fees may be assessed when the inspection record permit card is not posted or otherwise available on the work site, the approved plans are not readily available for the inspector, for failure to provide access on the date for which the inspection is requested, or for deviation from the plans requiring the approval of the building official. Where re-inspection fees have been assessed, no additional inspection of the work shall be performed until the required fees identified by the latest fees adopted by the City of Agoura Hills have been paid.*

t) Section 109.6.1 is added to read as follows:

**109.6.1 Refund Policy.** *The plan review fee for any project that has been reviewed will not be refunded since the review has been conducted already. When a project has been reviewed, approved and a permit has been issued, but no work or inspections has taken place and a refund is requested, the City will refund 80% of the original*

*permit fee for which no work or inspection has been performed. There will be no refund given if the project has commenced and inspection taken place. The Building Official makes the final determination whether a refund is due for a specific project.*

u) Section 109.7 is added to read as follows:

**109.7 Plan review fees.** *When submittal documents are required by Section 107, a plan review fee shall be paid at the time of submitting the submittal documents for plan review. Said plan review fee shall be in accordance with the schedule as established by the applicable governing authority.*

*The plan review fees specified in this section are in addition to and separate fees from the permit fees specified in Section 109.2.*

*Where submittal documents are incomplete or changed so as to require additional plan review, or where the project involves deferred submittal items as defined in Section 107.3.4.1, an additional plan review fee may be charged at a rate established by the applicable governing authority.*

*When submittal documents are for a project involving production housing (track home), the plan review fee shall be based on full plan review for the first model home/unit and 20% of the fee for any reproduction of that model home/unit. If the model home/unit and the reproduction units are not the same size and configuration, which would require a plan review, a full plan review fee or additional fee may apply, as determined by the Building Official.*

v) Section 110.1.1 is added to read as follows:

**110.1.1 Setback and height certification.** *When determined by the Building Official, a survey and certification may be required to confirm that the building or structure is placed on the site in accordance with the approved location and setback distances and to confirm that it does not exceed the approved building height shown on the approved plans.*

w) Section 110.3.4.2 is added to read as follows:

**110.3.4.2 Roof sheathing and shear inspection.** *Prior to a complete framing inspection, a roof sheathing and shear inspection shall be made after roof sheathing and all structural shear panels or walls are in place and secured by nailing or other approved methods.*

x) Exception for Section 110.3.6 is deleted

y) Section 111.1.1 is added to read as follows:



**111.1.1 Unpermitted Structures.** *No person shall own, use, occupy, or maintain an unpermitted structure. For purposes of this subsection, "unpermitted structure" shall be defined as any building or structure, or portion thereof, that was erected, constructed, enlarged, altered, repaired, moved, improved, removed, connected, converted, demolished, or equipped with regulated devices, fixtures or installations, at any point in time by any person, without the required permit(s) having first been obtained from the Building Official, or with a valid permit as issued by the Building Official which subsequently expired and became null and void. An unpermitted structure also includes one for which a building permit has been suspended or revoked.*

z) Section 111.2 is amended to read as follows:

**111.2 Certificate issued.** After the building official or his/her designee inspects the building or structure and finds no violation of the provisions of this code or other laws that are enforced by *the city*, the building official shall issue a certificate of occupancy that contains the following:

1. The *building* permit number.
2. The address of the structure.
3. The name and address of the owner or the owner's authorized agent.
4. A description of that portion of the structure for which the certificate is issued.
5. A statement that the described portion of the structure has been inspected for compliance with the requirements of this code *for the occupancy and division of occupancy and the use for which the proposed occupancy is classified.*
6. The name of the building official.
7. The edition of the code under which the permit was issued.
8. The use and occupancy, in accordance with the provisions of Chapter 3 *of the California Building Code.*
9. The type of construction as defined in Chapter 6 *of the California Building Code.*
10. The designed occupant load.
11. Where an automatic sprinkler system is provided, whether the sprinkler system is required
12. Any special stipulations and conditions of the building permit.
13. *Assessor's Parcel Number.*
14. *Zoning designation.*
15. *The date of certificate issuance.*

aa) Section 111.3 is amended to read as follows:

**111.3 Temporary Certificate of Occupancy (TCO)** *The Building Official may, in writing, authorize temporary occupancy of any building or structure, or portion thereof, that lacks a permanent certificate of occupancy for any reason, provided patent conditions in open and accessible portions of the building or structure do not reveal a substantial hazard to an occupant or occupants.*

*Applications for a temporary certificate of occupancy shall be on a city-approved form. Such applications shall be accompanied by a fee to process the application and for the inspection of the building or structure to determine its suitability for a temporary certificate of occupancy. Such fees shall be established by the City Council by resolution.*

*A temporary certificate of occupancy is valid for a period of time to be specified by the Building Official in the certificate. The city attorney may require applicants for a temporary certificate of occupancy to execute an indemnification, as approved by the city attorney, in favor of the city and its employees as a prerequisite to receiving a temporary certificate of occupancy.*

*The Building Official may extend the period of a temporary certificate of occupancy in writing, as well as impose conditions thereto. Property owners shall acknowledge and agree to said conditions in writing. The breach of any condition thereof shall render a temporary certificate of occupancy null and void without further action by the city. In such event, the owners shall cause all use and occupancy of the building or structure to be terminated by a date required by the Building Official. Use or occupancy of a building or structure, or allowing the use or occupancy of a building or structure, with an expired a temporary certificate of occupancy is a violation of this code and unlawful. Failing to cause the termination of all uses and occupancy in a structure after a termination date is a violation of this code and unlawful. The boards established by Section 1.8.8 do not have jurisdiction to consider, decide or rule decisions pertaining to the issuance, expiration or nullification of a temporary certificate of occupancy, or with regard to any other matter relating thereto.*

*The Building Official is authorized to adopt regulations or procedures, such as requiring security deposit or bond, for implementation of this section.*

bb) Section 111.4 is amended to read as follows:

**111.4 Revocation.** *The Building Official may, in writing, suspend or revoke a certificate of occupancy whenever the Building Official determines that the certificate was issued in error, or on the basis of incorrect information supplied, or when it is determined that the building, structure or premises, or portion thereof, is in violation of any provision of this code, or other relevant laws, ordinances, rules and/or regulations. Use or occupancy of a building or structure, or allowing the use or occupancy of a building or structure, with a suspended or revoked certificate of occupancy is a violation of this code and unlawful. The boards established by Section 1.8.8 do not have jurisdiction to consider, decide or rule pertaining to the issuance, suspension or revocation of a certificate of occupancy, or with regard to any other matter relating thereto.*

cc) Section 112.3 is amended and subsections 112.3.1, 112.3.2, and 112.3.3 are added to read as follows:

**112.3 Authority to Disconnect Service Utilities.** *The powers granted the Building Official pursuant to this subsection extend to all buildings, structures or systems (including electrical, plumbing and mechanical) that are regulated by this code and its references. This subsection supersedes all similar provisions in other codes that are part of Article VIII of the Agoura Hills Municipal Code.*

**112.3.1 Authority to Disconnect Electric Utility.** *The Building Official is hereby empowered to disconnect or to require in writing the discontinuance of electric utility service to buildings, structures or premises, or portions thereof, or to wiring, devices or materials where such buildings, structures or premises, or portions thereof, are determined to be a hazard to life, health and/or property, or where they lack permits and required inspection approvals.*

*The Building Official is hereby empowered to disconnect or to require in writing the discontinuance of electric utility service as a means of preventing, restraining, correcting or abating any violation of this code, or other relevant laws, ordinances, rules or regulations.*

*The electrical service shall remain disconnected or electrical utility service shall remain discontinued until the code violation has been abated to the satisfaction of the Building Official, or until the installation of such wiring, devices or materials have been made safe as directed by the Building Official; or until a permit has been issued and the work has been inspected and approved by the Building Official.*

**112.3.2 Authority to Disconnect Gas Utility.** *The Building Official is hereby empowered to disconnect or to require in writing the discontinuance of gas utility service to buildings, structures or premises, or portions thereof, or to appliances, devices or materials where such buildings, structures or premises, or portions thereof, are determined to be a hazard to life, health and/or property, or where they lack permits and required inspection approvals.*

*The Building Official is hereby empowered to disconnect or to require in writing the discontinuance of gas utility service as a means of preventing, restraining, correcting or abating any violation of this code, or other relevant laws, ordinances, rules or regulations.*

*The gas service shall remain disconnected or gas utility service shall remain discontinued until the code violation has been abated to the satisfaction of the Building Official, or until the installation of such appliances, devices or materials have been made safe as directed by the Building Official; or until a permit has been issued and the work has been inspected and approved by the Building Official.*

**112.3.3 Authority to Disconnect Water Utility.** *The Building Official is hereby empowered to disconnect or to require the property owner to*

*disconnect the water utility service to buildings, structures or premises, or portions thereof, or to fixtures, devices or materials where such buildings, structures or premises, or portions thereof, are determined to be a hazard to life, health, property or to the environment, or where they lack permits and required inspection approvals.*

*The Building Official is hereby empowered to disconnect or to require the property owner to disconnect the water utility service as a means of preventing, restraining, correcting or abating any violation of this code, or other relevant laws, ordinances, rules or regulations.*

*The water service shall remain disconnected or water utility service shall remain discontinued until the code violation has been abated to the satisfaction of the Building Official, or until the installation of such appliances, devices or materials have been made safe as directed by the Building Official; or until a permit has been issued and the work has been inspected and approved by the Building Official.*

dd) Section 113 is deleted in its entirety.

ee) Sections 114.1 is amended to read as follows:

**114.1 Unlawful Acts.** *It is unlawful for any property owner and/or other responsible person to erect, construct, alter, extend, repair, move, remove, demolish, or occupy any building or structure, as well as any regulated equipment, system or installation, or cause same to be done, in conflict with this code. It is unlawful for any for any property owner and/or other responsible person to conduct or maintain, whether due to action or inaction, any building or structure, as well as any regulated equipment, system or installation in violation of this code. It is unlawful for any property owner and/or other responsible person to conduct or maintain grading on land that occurred without a permit.*

ff) Section 114.4 is amended to read as follows:

**114.4 Violation Penalties.** *Any person who violates, or who maintains a violation of this Code or who fails to comply with any of the requirements thereof or who erects, constructs, alters or repairs a building or structure in violation of the approved construction documents or who fails to comply with a directive or order of the Building Official, or of a permit or certificate issued under the provisions of this code, shall be subject to penalties as prescribed by law as follows:*

(a) *Any person, firm, partnership, association, corporation or joint venture violating any of the provisions of the California Building Standards Code or other code(s) adopted in Article VIII of the Agoura Municipal Code shall be guilty of a misdemeanor. Any person violating a stop work order issued pursuant to Section 115.1 of this chapter shall be guilty of a misdemeanor. Any person*

*who continues to occupy or any person who enters a structure that has been posted "unsafe" by the building official pursuant to Section 116 of this chapter shall be guilty of a misdemeanor.*

*(b) Each day that person, firm, association, corporation or joint venture violates any of the provisions of the California Building Standards Code or other code(s) adopted in Article VIII of the Agoura Municipal Code is a separate offense and shall be punishable thereof as provided in the Agoura Hills Municipal Code.*

gg) Section 115.1 is amended to read as follows:

**115.1 Authority.** Whenever the building official finds any work regulated by this code being performed in a manner either contrary to the provisions of this code, *or without a permit*, or dangerous, or unsafe, the Building Official is authorized to issue a stop work order.

hh) Section 116.1 is amended to read as follows:

**116.1 Unsafe Conditions.** *Any building, structure or equipment that has any or all of the conditions hereinafter described shall constitute an unsafe or dangerous building or structure:*

*(a) Structural inadequacies, damage, deficiencies, defects or deterioration, as well as nearby hazardous embankments or excavations, that could cause a building or structure to partially or completely collapse or fail.*

*(b) Electrical, plumbing or mechanical work or installations, which because of a defect in materials or installation, or due to some other faulty operating or other condition, pose a risk of explosion or fire.*

*(c) Unsanitary or unhealthful conditions that are present in a building or structure.*

*(d) All forms of construction, as well as electrical, plumbing or mechanical work, systems, fixtures, appliances or other installations for which all required permits and inspection approvals have not been obtained from the Building Official.*

*(e) Occupancy or use for which a building or structure was not designed or intended, or that results in a change in the occupancy classification thereof.*

*(f) Inadequate egress from a building or structure.*

*(g) A vacant building or structure that is not secured against unauthorized entry.*

*(h) Any condition that violates any regulation in Article VIII of the Agoura Hills Municipal Code.*

*Any or all of the foregoing conditions endanger the health, safety or welfare of occupants, persons who may enter the premises, or the public. Unsafe structures shall be taken down and removed or made safe*

ii) *Section 116.3.1 is added to read as follows:*

**Section 116.3.1 Orders to Vacate.** *Notwithstanding any other provision of this code, if the building official or a designee thereof, determines a condition is present in a building or structure or on premises that constitutes an immediate danger or hazard to the health, safety or welfare of occupants or to the public, the Building Official may order persons to vacate buildings, structures, premises, or portions thereof. Such orders may include orders to not re-enter, as well authorize limited entry subject to written conditions. Conditions may include, but not be limited to, requiring buildings, structures, and premises to be secured from entry or access by means that are acceptable to the Building Official. Orders shall advise persons of their appeal rights as discussed in this subsection.*

*Orders may be personally served on an occupant, or served by first class mail and posted on the premises containing the immediate danger or hazard. If an owner does not occupy said premises, a copy of the order shall be also sent by first class mail to the owner as identified by Los Angeles County Assessor records. For owner-occupied properties, the issuance date of an order is the date of its personal service. For non-owner occupied properties, the issuance date of an order is the date an order to the owner and any occupant(s), or a copy thereof, are deposited in a U.S. Postal Service mail container and posted on the premises. Failure of any person to receive an order shall not affect its validity, or the appeal period. When identifying a mailing address for an owner, the Building Official shall consider such information as shown in Los Angeles County Assessor records.*

*Orders issued pursuant to this subsection, and any conditions thereof, are appealable by a property owner or occupant on a City-approved form that must be received by the City Clerk's Office within ten days of an order's issuance. Appellants shall state all grounds for their appeal in said form. Failure to tender an appeal in a timely manner constitutes a waiver of the right to appeal, in which case an order is final.*

*If a timely appeal is made, the Building & Safety Department shall provide ten days advance written notice to the appealing party or parties of the date, time and place of the hearing. A timely appeal does not stay an order, or any conditions thereof. Failure of any person to receive a notice of hearing shall not affect its validity.*

*Timely appeals shall be heard by the housing or local appeals board, as applicable. Appeal hearings are informal and rules of evidence do not apply. Failure of an appellant or appellants to appear at a hearing constitutes a waiver of the right to appeal, in which case the order is final. The housing or local appeals board, as applicable shall, within ten days following the hearing, issue a written decision upholding, modifying, or reversing the order or conditions thereof, notice of which shall*

*be sent to the appellant(s) by first class mail. Such decisions are not appealable. The notice of decision shall contain the following statement: "The [Housing Appeals Board/Local Appeals Board] decision is final, and judicial review of this decision is subject to the provisions and time limits set forth in Cal. Code of Civil Procedure §§ 1094.5 and 1094.6."*

*Orders may be accompanied by, or combined with, Stop Work Order or Notices of Violations (which are not appealable). Orders shall be rescinded in writing when the Building Official determines that the immediate danger or hazard has been fully corrected or abated with all permits, approvals and inspections as required by the Agoura Hills Municipal Code.*

jj) Sections 116.4 and 116.5 are deleted.

kk) Section 116.6 is added to read as follows:

**Section 116.6 Violations.** *It is unlawful and a public nuisance for any person to maintain an unsafe or dangerous building or structure. Each and every day that a building or structure is maintained in an unsafe or dangerous condition is a new violation of this code. It is a violation of this code and unlawful for any person to fail to comply with an order to vacate, as well as all conditions thereof. Each such violation shall be a misdemeanor.*

ll) Section 701A.1 is amended to read as follows:

**701A.1 Scope.** This Chapter applies to building materials, systems, and/or assemblies used in the exterior design and construction of all new buildings, *and to additions, alterations, or repairs made to all existing buildings, erected, constructed, or moved, in the City of Agoura Hills or within a Wildland-Urban Interface (WUI) Fire Area as defined in Section 702A.*

mm) Section 701A.3 is amended to read as follows:

**701A.3 Application.** *New buildings, and any additions, alterations, or repairs made to existing buildings located in or moved within the City of Agoura Hills, or in any Fire Hazard Severity Zone, or in any Wildland-Urban Interface (WUI) Fire Area designated by the enforcing agency, that is constructed after the application date shall comply with the provisions of this Chapter (see Section 701A.3.1). This shall include all new buildings, and any additions, alterations, or repairs made to existing buildings, with residential, commercial, educational, institutional or similar occupancy type use, which shall be referred to in this chapter as "applicable building(s)" (see definition in Section 702A), as well as new buildings and structures, and any additions, alterations, or repairs made to existing buildings accessory to those applicable buildings (see Exceptions 1 and 4).*

**Exceptions:**

1. Group U occupancy accessory buildings of any size located at least 50 feet (15 240 mm) from an applicable building on the same lot.
2. Group U occupancy agricultural buildings, as defined in Section 202 of this code of any size located at least 50 feet from an applicable building.
3. Group C occupancy special buildings conforming to the limitations specified in Section 450.4.1.
4. Accessory buildings and miscellaneous structures, *including additions, alterations, or repairs*, as specified in Section 710A shall comply only with the requirements of that Section.
5. *Reserved.*

nn) Section 701A.3.1 is amended to read as follows:

**701A.3.1 Application date and where required.** New buildings for which an application for a building permit is submitted on or after July 1, 2008, *and any additions, alterations, or repairs made to existing buildings for which an application for a building permit is submitted on or after January 1, 2023*, located in the City of Agoura Hills, or in any Fire Hazard Severity Zone, or in any Wildland–Urban Interface Fire Area shall comply with all sections of this Chapter.

oo) Section 705A.2 is added to read as follows:

**705A.2. Roof coverings.** *Roof coverings shall be Class A as specified in Section 1505.2.* Where the roofing profile has an airspace under the roof covering, installed over a combustible deck, a 72 lb. (32.7 kg) cap sheet complying with ASTM D3909 Standard Specification for “Asphalt Rolled Roofing (Glass Felt) Surfaced with Mineral Granules,” shall be installed over the roof deck. Bird stops shall be used at the eaves when the profile fits, to prevent debris at the eave. Hip and ridge caps shall be mudded in to prevent intrusion of fire or embers.

**Exception:**

Cap sheet is not required when no less than 1” of mineral wool board or other noncombustible material is located between the roofing material and wood framing or deck.

Alternately, a Class A fire rated roof underlayment, tested in accordance with ASTM E108, shall be permitted to be used. If the sheathing consists of exterior fire- retardant-treated wood, the underlayment shall not be required to comply with a Class A classification. Bird stops shall be used at the eaves when the profile fits, to prevent debris at the eave. Hip and ridge caps shall be mudded in to prevent intrusion of fire



or embers. *Wood shingles and wood shakes are prohibited in the City of Agoura Hills or any Fire Hazard Severity Zones regardless of classification.*

pp) Section 903.2 is amended to read as follows:

**903.2 Where required.** *An approved automatic fire sprinkler system shall be installed:*

1. *Throughout all new buildings.*

**Exceptions:**

1. *An automatic residential fire sprinkler system shall not be required when additions or alterations are made to existing carports and/or garages that do not have an automatic residential fire sprinkler systems installed in accordance with this code.*
  2. *Accessory buildings in group U occupancy, used for storage, where floor area is not more than 200 square feet and the building is separated from other buildings by a minimum of 10 feet.*
  3. *Detached gazebos, pergolas and carports open on two or more sides and separated from other buildings by a minimum of 20 feet.*
  4. *Alterations to an existing detached single family residence with no existing fire sprinkler system in place where less than 50% of existing building is being altered.*
  5. *Non-combustible detached structures, less than 600 square feet, not used for human occupancy with minimum separation of 20 feet from other buildings.*
2. *Throughout the entire building where the floor area for the addition exceeds 50% of the existing floor area within any 12-month period.*
  3. *In addition to existing buildings already equipped with an automatic fire sprinkler system.*

*For the purpose of requiring the automatic fire sprinkler systems specified in this chapter, the entire floor area within the building footprint, including attached garage area shall be considered.*

*An automatic fire sprinkler system need not be installed in spaces or areas in telecommunications buildings used exclusively for telecommunications equipment, associated electrical power distribution equipment, batteries and standby engines, provided those spaces or areas are equipped throughout with an automatic fire alarm system and are separated from the remainder of the building by fire barriers consisting of not less than 1-hour fire-resistance-rated walls and 2-hour fire-resistance-rated floor/ceiling assemblies.*

qq) Section 1613.5 is added to read as follows:

**1613.5 Seismic design provisions for hillside buildings.**

**1613.5.1 Purpose.** *The purpose of this section is to establish minimum regulations for the design and construction of new buildings and additions to existing buildings when constructing such buildings on or into slopes steeper than one unit vertical in three units horizontal (33.3%). These regulations establish minimum standards for seismic force resistance to reduce the risk of injury or loss of life in the event of earthquakes.*

**1613.5.2 Scope.** *The provisions of this section shall apply to the design of the lateral-force-resisting system for hillside buildings at and below the base level diaphragm. The design of the lateral-force-resisting system above the base level diaphragm shall be in accordance with the provisions for seismic and wind design as required elsewhere in this division.*

**Exception:** *Non-habitable accessory buildings and decks not supporting or supported from the main building are exempt from these regulations.*

**1613.5.3 Definitions.** *For the purposes of this section certain terms are defined as follows:*

*BASE LEVEL DIAPHRAGM is the floor at, or closest to, the top of the highest level of the foundation.*

*DIAPHRAGM ANCHORS are assemblies that connect a diaphragm to the adjacent foundation at the uphill diaphragm edge.*

*DOWNHILL DIRECTION is the descending direction of the slope approximately perpendicular to the slope contours.*

*FOUNDATION is concrete or masonry which supports a building, including footings, stem walls, retaining walls, and grade beams.*

*FOUNDATION EXTENDING IN THE DOWNHILL DIRECTION is a foundation running downhill and approximately perpendicular to the uphill foundation.*

*HILLSIDE BUILDING is any building or portion thereof constructed on or into a slope steeper than one unit vertical in three units horizontal (33.3%). If only a portion of the building is supported on or into the slope, these regulations apply to the entire building.*

*PRIMARY ANCHORS are diaphragm anchors designed for and providing a direct connection as described in Sections 1613.5.5 and 1613.5.7.3 between the diaphragm and the uphill foundation.*

*SECONDARY ANCHORS are diaphragm anchors designed for and providing a redundant diaphragm to foundation connection, as described in Sections 1613.5.6 and 1613.5.7.4.*

*UPHILL DIAPHRAGM EDGE is the edge of the diaphragm adjacent and closest to the highest ground level at the perimeter of the diaphragm.*

*UPHILL FOUNDATION is the foundation parallel and closest to the uphill diaphragm edge.*

#### **1613.5.4 Analysis and design.**

**1613.5.4.1 General.** *Every hillside building within the scope of this section shall be analyzed, designed, and constructed in accordance with the provisions of this division. When the code-prescribed wind design produces greater effects, the wind design shall govern, but detailing requirements and limitations prescribed in this and referenced sections shall be followed.*

**1613.5.4.2 Base level diaphragm-downhill direction.** *The following provisions shall apply to the seismic analysis and design of the connections for the base level diaphragm in the downhill direction.*

**1613.5.4.2.1 Base for lateral force design defined.** *For seismic forces acting in the downhill direction, the base of the building shall be the floor at or closest to the top of the highest level of the foundation.*

**1613.5.4.2.2 Base shear.** *In developing the base shear for seismic design, the response modification coefficient (R) shall not exceed 5 for bearing wall and building frame systems. The total base shear shall include the forces tributary to the base level diaphragm including forces from the base level diaphragm.*

#### **1613.5.5 Base shear resistance-primary anchors.**

**1613.5.5.1 General.** *The base shear in the downhill direction shall be resisted through primary anchors from diaphragm struts provided in the base level diaphragm to the foundation.*

**1613.5.5.2 Location of primary anchors.** *A primary anchor and diaphragm strut shall be provided in line with each foundation extending in the downhill direction. Primary anchors and diaphragm struts shall also be provided where interior vertical lateral-force-resisting elements occur above*

and in contact with the base level diaphragm. The spacing of primary anchors and diaphragm struts or collectors shall in no case exceed 30 feet (9144 mm).

**1613.5.5.3 Design of primary anchors and diaphragm struts.** Primary anchors and diaphragm struts shall be designed in accordance with the requirements of Section 1613.5.8.

**1613.5.5.4 Limitations.** The following lateral-force-resisting elements shall not be designed to resist seismic forces below the base level diaphragm in the downhill direction:

1. Wood structural panel wall sheathing,
2. Cement plaster and lath,
3. Gypsum wallboard, and
4. Tension only braced frames.

Braced frames designed in accordance with the requirements of Section 2205.2.1.2 may be used to transfer forces from the primary anchors and diaphragm struts to the foundation provided lateral forces do not induce flexural stresses in any member of the frame or in the diaphragm struts. Deflections of frames shall account for the variation in slope of diagonal members when the frame is not rectangular.

**1613.5.6 Base shear resistance-secondary anchors.**

**1613.5.6.1 General.** In addition to the primary anchors required by Section 1613.5.5, the base shear in the downhill direction shall be resisted through secondary anchors in the uphill foundation connected to diaphragm struts in the base level diaphragm.

**Exception:** Secondary anchors are not required where foundations extending in the downhill direction spaced at not more than 30 feet (9144 mm) on center extend up to and are directly connected to the base level diaphragm for at least 70% of the diaphragm depth.

**1613.5.6.2 Secondary anchor capacity and spacing.** Secondary anchors at the base level diaphragm shall be designed for a minimum force equal to the base shear, including forces tributary to the base level diaphragm, but not less than 600 pounds per lineal foot (8.76 kN/m) based on Allowable Stress Design (ASD) levels. The secondary anchors shall be uniformly distributed along the uphill diaphragm edge and shall be spaced a maximum of 4 feet (1219 mm) on center.

**1613.5.6.3 Design.** Secondary anchors and diaphragm struts shall be designed in accordance with Section 1613.5.8.

**1613.5.7 Diaphragms below the base level-downhill direction.** The following provisions shall apply to the lateral analysis and design of the connections for all diaphragms below the base level diaphragm in the downhill direction.

**1613.5.7.1 Diaphragm defined.** Every floor level below the base level diaphragm shall be designed as a diaphragm.

**1613.5.7.2 Design force.** Each diaphragm below the base level diaphragm shall be designed for all tributary loads at that level using a minimum seismic force factor not less than the base shear coefficient.

**1613.5.7.3 Design force resistance-primary anchors.** The design force described in Section 1613.5.7.2 shall be resisted through primary anchors from diaphragm struts provided in each diaphragm to the foundation. Primary anchors shall be provided and designed in accordance with the requirements and limitations of Section 1613.5.5.

**1613.5.7.4 Design force resistance-secondary anchors.**

**1613.5.7.4.1 General.** In addition to the primary anchors required in Section 1613.5.7.3, the design force in the downhill direction shall be resisted through secondary anchors in the uphill foundation connected to diaphragm struts in each diaphragm below the base level.

**Exception:** Secondary anchors are not required where foundations extending in the downhill direction, spaced at not more than 30 feet (9144 mm) on center, extend up to and are directly connected to each diaphragm below the base level for at least 70% of the diaphragm depth.

**1613.5.7.4.2 Secondary anchor capacity.** Secondary anchors at each diaphragm below the base level diaphragm shall be designed for a minimum force equal to the design force but not less than 300 pounds per lineal foot (4.38 kN/m) based on Allowable Stress Design (ASD) levels. The secondary anchors shall be uniformly distributed along the uphill diaphragm edge and shall be spaced a maximum of 4 feet (1219 mm) on center.

**1613.5.7.4.3 Design.** Secondary anchors and diaphragm struts shall be designed in accordance with Section 1613.5.8.

**1613.5.8 Primary and secondary anchorage and diaphragm strut design.** Primary and secondary anchors and diaphragm struts shall be designed in accordance with the following provisions:

1. *Fasteners. All bolted fasteners used to develop connections to wood members shall be provided with square plate washers at all bolt heads and nuts. Washers shall be minimum 0.229 inch by 3 inches by 3 inches (5.82 mm by 76 mm by 76 mm) in size. Nuts shall be tightened to finger tight plus one half (1/2) wrench turn prior to covering the framing.*
2. *Fastening. The diaphragm to foundation anchorage shall not be accomplished by the use of toenailing, nails subject to withdrawal, or wood in cross-grain bending or cross-grain tension.*
3. *Size of Wood Members. Wood diaphragm struts collectors, and other wood members connected to primary anchors shall not be less than 3 inch (76 mm) nominal width. The effects of eccentricity on wood members shall be evaluated as required per Item 9.*
4. *Design. Primary and secondary anchorage, including diaphragm struts, splices, and collectors shall be designed for 125% of the tributary force.*
5. *Allowable Stress Increase. The one-third allowable stress increase permitted under Section 1605.3.2 shall not be taken when the working (allowable) stress design method is used.*
6. *Steel Element of Structural Wall Anchorage System. The strength design forces for steel elements of the structural wall anchorage system, with the exception of anchor bolts and reinforcing steel, shall be increased by 1.4 times the forces otherwise required.*
7. *Primary Anchors. The load path for primary anchors and diaphragm struts shall be fully developed into the diaphragm and into the foundation. The foundation must be shown to be adequate to resist the concentrated loads from the primary anchors.*
8. *Secondary Anchors. The load path for secondary anchors and diaphragm struts shall be fully developed in the diaphragm but need not be developed beyond the connection to the foundation.*
9. *Symmetry. All lateral force foundation anchorage and diaphragm strut connections shall be symmetrical. Eccentric connections may be permitted when demonstrated by calculation or tests that all components of force have been provided for in the structural analysis or tests.*
10. *Wood Ledgers. Wood ledgers shall not be used to resist cross-grain bending or cross-grain tension.*

**1613.5.9 Lateral-force-resisting elements normal to the downhill direction.**

**1613.5.9.1 General.** *In the direction normal to the downhill direction, lateral-force-resisting elements shall be designed in accordance with the requirements of this section.*

**1613.5.9.2 Base shear.** *In developing the base shear for seismic design, the response modification coefficient (R) shall not exceed 5 for bearing wall and building frame systems.*

**1613.5.9.3 Vertical distribution of seismic forces.** *For seismic forces acting normal to the downhill direction the distribution of seismic forces over the height of the building using Section 12.8.3 of ASCE 7 shall be determined using the height measured from the top of the lowest level of the building foundation.*

**1613.5.9.4 Drift limitations.** *The story drift below the base level diaphragm shall not exceed 0.007 times the story height at strength design force level. The total drift from the base level diaphragm to the top of the foundation shall not exceed 3/4 inch (19 mm). Where the story height or the height from the base level diaphragm to the top of the foundation varies because of a stepped footing or story offset, the height shall be measured from the average height of the top of the foundation. The story drift shall not be reduced by the effect of horizontal diaphragm stiffness.*

**1613.5.9.5 Distribution of lateral forces.**

**1613.5.9.5.1 General.** *The design lateral force shall be distributed to lateral-force-resisting elements of varying heights in accordance with the stiffness of each individual element.*

**1613.5.9.5.2 Wood structural panel sheathed walls.** *The stiffness of a stepped wood structural panel shear wall may be determined by dividing the wall into adjacent rectangular elements, subject to the same top of wall deflection. Deflections of shear walls may be estimated by AWC SDPWS Section 4.3.2. Sheathing and fastening requirements for the stiffest section shall be used for the entire wall. Each section of wall shall be anchored for shear and uplift at each step. The minimum horizontal length of a step shall be 8 feet (2438 mm) and the maximum vertical height of a step shall be 2 feet 8 inches (813 mm).*

**1613.5.9.5.3 Reinforced concrete or masonry shear walls.** *Reinforced concrete or masonry shear walls shall have forces distributed in proportion to the rigidity of each section of the wall.*

**1613.5.9.6 Limitations.** *The following lateral force-resisting-elements shall not be designed to resist lateral forces below the base level diaphragm in the direction normal to the downhill direction:*

1. Cement plaster and lath,
2. Gypsum wallboard, and
3. Tension-only braced frames.

*Braced frames designed in accordance with the requirements of Section 2205.2.1.2 of this Code may be designed as lateral-force-resisting elements in the direction normal to the downhill direction, provided lateral forces do not induce flexural stresses in any member of the frame. Deflections of frames shall account for the variation in slope of diagonal members when the frame is not rectangular.*

#### **1613.5.10 Specific design provisions.**

**1613.5.10.1 Footings and grade beams.** *All footings and grade beams shall comply with the following:*

1. *Grade beams shall extend at least 12 inches (305 mm) below the lowest adjacent grade and provide a minimum 24 inch (610 mm) distance horizontally from the bottom outside face of the grade beam to the face of the descending slope.*
2. *Continuous footings shall be reinforced with at least two No. 4 reinforcing bars at the top and two No. 4 reinforcing bars at the bottom.*
3. *All main footing and grade beam reinforcement steel shall be bent into the intersecting footing and fully developed around each corner and intersection.*
4. *All concrete stem walls shall extend from the foundation and reinforced as required for concrete or masonry walls.*

**1613.5.10.2 Protection against decay and termites.** *All wood to earth separation shall comply with the following:*

1. *Where a footing or grade beam extends across a descending slope, the stem wall, grade beam, or footing shall extend up to a minimum 18 inches (457 mm) above the highest adjacent grade.*

**Exception:** *At paved garage and doorway entrances to the building, the stem wall need only extend to the finished concrete slab, provided the wood framing is protected with a moisture proof barrier.*

2. *Wood ledgers supporting a vertical load of more than 100 pounds per lineal foot (1.46 kN/m) based on Allowable Stress Design (ASD) levels and located within 48 inches (1219 mm) of adjacent grade are prohibited. Galvanized steel ledgers and anchor bolts, with or without wood nailers, or*



*treated or decay resistant sill plates supported on a concrete or masonry seat, may be used.*

**1613.5.10.3 Sill plates.** *All sill plates and anchorage shall comply with the following:*

- 1. All wood framed walls, including nonbearing walls, when resting on a footing, foundation, or grade beam stem wall, shall be supported on wood sill plates bearing on a level surface.*
- 2. Power-driven fasteners shall not be used to anchor sill plates except at interior nonbearing walls not designed as shear walls.*

**1613.5.10.4 Column base plate anchorage.** *The base of isolated wood posts (not framed into a stud wall) supporting a vertical load of 4,000 pounds (17.8 kN) based on Allowable Stress Design (ASD) levels or more and the base plate for a steel column shall comply with the following:*

- 1. When the post or column is supported on a pedestal extending above the top of a footing or grade beam, the pedestal shall be designed and reinforced as required for concrete or masonry columns. The pedestal shall be reinforced with a minimum of four No. 4 bars extending to the bottom of the footing or grade beam. The top of exterior pedestals shall be sloped for positive drainage.*
- 2. The base plate anchor bolts or the embedded portion of the post base, and the vertical reinforcing bars for the pedestal, shall be confined with two No. 4 or three No. 3 ties within the top 5 inches (127 mm) of the concrete or masonry pedestal. The base plate anchor bolts shall be embedded a minimum of 20 bolt diameters into the concrete or masonry pedestal. The base plate anchor bolts and post bases shall be galvanized and each anchor bolt shall have at least 2 galvanized nuts above the base plate.*

**1613.5.10.5 Steel beam to column supports.** *All steel beam to column supports shall be positively braced in each direction. Steel beams shall have stiffener plates installed on each side of the beam web at the column. The stiffener plates shall be welded to each beam flange and the beam web. Each brace connection or structural member shall consist of at least two 5/8 inch (15.9 mm) diameter machine bolts.*

rr) Section 1807.1.4 is amended to read as follows:

**1807.1.4 Permanent wood foundation systems.** Permanent wood foundation systems shall be designed and installed in accordance with AWC PWF. Lumber and plywood shall be treated in accordance with AWPA U1 (Commodity Specification A, Special Requirement 4.2) and shall be identified in accordance with Section

2303.1.9.1. *Permanent wood foundation systems shall not be used for structures assigned to Seismic Design Category D, E or F.*

ss) Section 1807.2 is amended to read as follows:

**1807.2 Retaining walls.** Retaining walls shall be designed in accordance with Section 1807.2.1 through 1807.2.4. *Retaining walls assigned to Seismic Design Category D, E or F shall not be partially or wholly constructed of wood.*

tt) Section 1809.3 is amended to read as follows:

**1809.3 Stepped footings.** The top surface of footings shall be level. The bottom surface of footings shall be permitted to have a slope not exceeding one unit vertical in 10 units horizontal (10-percent slope). Footings shall be stepped where it is necessary to change the elevation of the top surface of the footing or where the surface of the ground slopes more than one unit vertical in 10 units horizontal (10-percent slope).

*For structures assigned to Seismic Design Category D, E or F, the stepping requirement shall also apply to the top surface of continuous footings supporting walls. Footings shall be reinforced with four No. 4 deformed reinforcing bars. Two bars shall be placed at the top and bottom of the footings as shown in Figure 1809.3.*

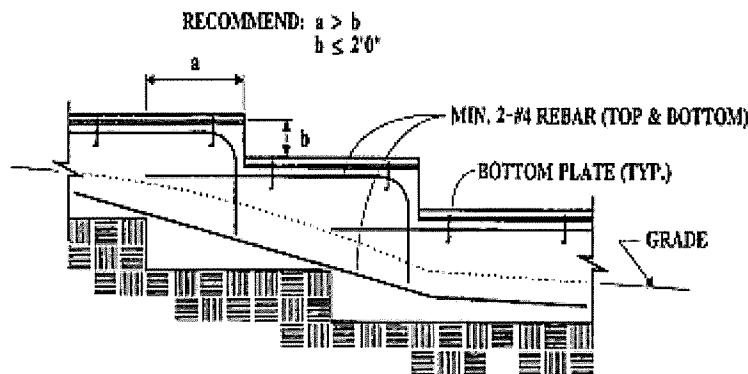

STEPPED FOUNDATIONS

**FIGURE 1809.3**  
**STEPPED FOOTING**

uu) Section 1809.7 and Table 1809.7 are amended to read as follows:

**1809.7 Prescriptive footings for light-frame construction.** Where a specific design is not provided, concrete or masonry-unit footings supporting walls of light-frame construction shall be permitted to be designed in accordance with Table 1809.7. *Light-frame construction using prescriptive footings in Table 1809.7 shall not exceed one*

story above grade plane for structures assigned to Seismic Design Category D, E or F.

**TABLE 1809.7**  
**PRESCRIPTIVE FOOTINGS SUPPORTING WALLS OF**  
**LIGHT-FRAME CONSTRUCTION** <sup>a, b, c, d, e</sup>

NUMBER OF FLOORS SUPPORTED BY THE FOOTING <sup>f</sup>	WIDTH OF FOOTING (inches)	THICKNESS OF FOOTING (inches)
1	12	6
2	15	6
3	18	8

For SI: 1 inch = 25.4 mm, 1 foot = 304.8 mm

- a. Depth of footings shall be in accordance with Section 1809.4.
- b. The ground under the floor shall be permitted to be excavated to the elevation of the top of the footing.
- c. Not Adopted.
- d. See Section 1905 for additional requirements for concrete footings of structures assigned to Seismic Design Category C, D, E or F.
- e. For thickness of foundation walls, see Section 1807.1.6.
- f. Footings shall be permitted to support a roof addition to the stipulated number of floors. Footings supporting roof only shall be as required for supporting one floor.

vv) Section 1809.12 is amended to read as follows:

**1809.12 Timber footings.** Timber footings shall be permitted for buildings of Type V construction and as otherwise approved by the Building Official. Such footings shall be treated in accordance with AWP A U1 (Commodity Specification A, Use Category 4B). Treated timbers are not required where placed entirely below permanent water level, or where used as capping for wood piles that project above the water level over submerged or marsh lands. The compressive stresses perpendicular to grain in untreated timber footings supported on treated piles shall not exceed 70 percent of the allowable stresses for the species and grade of timber as specified in the ANS/AWC NDS. Timber footings shall not be used in structures assigned to Seismic Design Category D, E or F.

ww) Section 2304.10.2 is amended to read as follows:

**2304.10.2 Fastener requirements.** Connections for wood members shall be designed in accordance with the appropriate methodology in Section 2302.1. The number and size of fasteners connecting wood members shall not be less than that set forth in Table 2304.10.2. *Staple fasteners in Table 2304.10.2 shall not be used to resist or transfer seismic forces in structures assigned to Seismic Design Category D, E or F.*

**Exception:** *Staples may be used to resist or transfer seismic forces when the allowable shear values are substantiated by cyclic testing and approved by the building official.*

xx) Section 2304.12.2.8 is amended to read as follows:

**2304.12.2.8 Wood used in retaining walls and cribs.** Wood installed in retaining or crib walls shall be preservative treated in accordance with AWWPA U1 for soil and fresh water use. *Wood shall not be used in retaining or crib walls for structures assigned to Seismic Design Category D, E or F.*

yy) Section 2306.2 is amended to read as follows:

**2306.2 Wood-frame diaphragms.** Wood-frame diaphragms shall be designed and constructed in accordance with AWC SDPWS. Where panels are fastened to framing members with staples, requirements and limitations of AWC SDPWS shall be met and the allowable shear values set forth in Table 2306.2(1) or 2306.2(2) shall *only* be permitted *for structures assigned to Seismic Design Category A, B, or C.*

**Exception:** *Allowable shear values where panels are fastened to framing members with staples may be used if such values are substantiated by cyclic testing and approved by the building official.*

The allowable shear values in Tables 2306.2(1) and 2306.2(2) are permitted to be increased 40 percent for wind design.

*Wood structural panels used to resist seismic diaphragm forces in structures assigned to Seismic Design Category D, E or F shall be applied directly to the framing members.*

**Exception:** *Wood structural panels are permitted to be fastened over solid lumber planking or laminated decking, provided the panel joints and lumber planking or laminated decking joints do not coincide.*

zz) Section 2306.3 is amended to read as follows:

**2306.3 Wood-frame shear walls.** Wood-frame shear walls shall be designed and constructed in accordance with ANSI/AWC SDPWS. *For structures assigned to Seismic Design Category D, E, or F, application of Table 4.3A of ANSI/AWC SDPWS shall include the following:*

- i. Wood structural panel thickness for shear walls shall not be less than 3/8 inch thick and studs shall not be spaced at more than 16 inches on center.*
- ii. The maximum nominal unit shear capacities for 3/8 inch wood structural panels resisting seismic forces in structures assigned to Seismic Design Category D, E or F is 400 pounds per linear foot (plf).*

**Exception:** *Other nominal unit shear capacities may be permitted if such values are substantiated by cyclic testing and approved by the building official.*

*iii. Nails shall be placed not less than 1/2 inch in from the panel edges and not less than 3/8 inch from the edge of the connecting members for shear greater than 350 plf using ASD or 500 plf using LRFD. Nails shall be placed not less than 3/8 inch from panel edges and not less than 1/4 inch from the edge of the connecting members for shears of 350 plf or less using ASD or 500 plf or less using LRFD.*

*For structures assigned to Seismic Design Category D, E or F, application of Table 4.3B of ANSI/AWC SDPWS shall not be allowed.*

*For structures assigned to Seismic Design Category D, E or F, application of Table 4.3C of ANSI/AWC SDPWS shall not be used below the top level in a multi-level building.*

Where panels are fastened to framing members with staples, requirements and limitations of AWC SDPWS shall be met and the allowable shear values set forth in Table 2306.3(1), 2306.3(2) or 2306.3(3) shall *only* be permitted for structures assigned to Seismic Design Category A, B, or C.

**Exception:** *Allowable shear values where panels are fastened to framing members with staples may be used if such values are substantiated by cyclic testing and approved by the building official.*

The allowable shear values in Tables 2306.3(1) and 2306.3(2) are permitted to be increased 40 percent for wind design. Panels complying with ANSI/APA PRP-210 shall be permitted to use design values for Plywood Siding in the ANSI/AWC SDPWS.

aaa) Section 2308.6.8.1 is amended to read as follows:

**2308.6.8.1 Foundation requirements.** *Braced wall lines shall be supported by continuous foundations.*

**Exception:** *For structures with a maximum plan dimension not more than 50 feet (15240 mm), continuous foundations are required at exterior walls only for structures assigned to Seismic Design Category A, B, or C.*

For structures in Seismic Design Categories D and E, exterior braced wall panels shall be in the same plane vertically with the foundation or the portion of the structure containing the offset shall be designed in accordance with accepted engineering practice and Section 2308.1.1.

bbb) Section 3109.2 is amended by adding a new definition for "Barrier" and amending the existing definitions for "Swimming Pool" to read as follows:

**Barrier.** *Barrier is a fence, wall, building wall or other enclosure that isolates a swimming pool from access to the home, other properties or the public.*

**Swimming Pools/Spa.** *Any body of water created by artificial means which is designed, intended for use, or used for swimming or immersion purposes, which has a water depth exceeding 18 inches. The term "pool" includes swimming pools, spas, hot tubs, above and below ground, and vinyl-lined pools; "Pool" does not include plumbing fixtures such as bathtubs nor does it apply to man-made lakes, reservoirs, farm ponds, or ponds used primarily for public park purposes, water conservation purposes, irrigation purposes or for the watering of livestock.*

ccc)Section 3115 is amended to read as follows:

## **SECTION 3115 INTERMODAL SHIPPING CONTAINERS**

**3115.1 General.** The provisions of Section 3115 and other applicable sections of this code shall apply to intermodal shipping containers that are repurposed for use as buildings or structures or as a part of buildings or structures.

### **Exceptions:**

1. Intermodal shipping containers previously approved as existing relocatable buildings complying with Chapter 14 of the California Existing Building Code.
2. Stationary battery storage arrays located in intermodal shipping containers complying with Chapter 12 of the California Fire Code.
3. Intermodal shipping containers that are listed as equipment complying with the standard for equipment, such as air chillers, engine generators, modular data centers, and other similar equipment.
4. Intermodal shipping containers housing or supporting experimental equipment are exempt from the requirements of Section 3115, provided they comply with all of the following:
  - 4.1. Such units will be single stand-alone units supported at grade level and used only for occupancies as specified under Risk Category I in Table 1604.5.
  - 4.2. Such units are located a minimum of 8 feet (2438 mm) from adjacent structures, and are not connected to a fuel gas system or fuel gas utility.
  - 4.3. In hurricane-prone regions and flood hazard areas, such units are designed in accordance with the applicable provisions of Chapter 16.
5. *Shipping containers constructed or converted off-site that meet the definition of Factory-built Housing in Health and Safety Code Section 19971 or Commercial*

*Modular(s) as defined in Health and Safety Code Section 18001.8 shall be approved by the Department of Housing and Community Development.*

6. *Single-unit stand-alone intermodal shipping containers used as temporary storage or construction trailer on active construction sites. Construction support facilities for uses and activities not directly associated with the actual processes of construction, including but not limited to, offices, meeting rooms, plan rooms, other administrative or support functions shall not be exempt from Section 3115.*

**3115.2 Construction documents.** The construction documents shall contain information to verify the dimensions and establish the physical properties of the steel components and wood floor components of the intermodal shipping container, in addition to the information required by Sections 107 and 1603.

**3115.3 Intermodal shipping container information.** Intermodal shipping containers shall bear an existing data plate containing the following information as required by ISO 6346 and verified by an approved agency. A report of the verification process and findings shall be provided to the building owner.

1. Manufacturer's name or identification number.
2. Date manufactured.
3. Safety approval number.
4. Identification number.
5. Maximum operating gross mass or weight (kg) (lbs).
6. Allowable stacking load for 1.8G (kg) (lbs).
7. Transverse racking test force (Newtons).
8. Valid maintenance examination date.

Where approved by the building official, the markings and existing data plate are permitted to be removed from the intermodal shipping containers before they are repurposed for use as buildings or structures or as part of buildings or structures.

**3115.4 Protection against decay and termites.** Wood structural floors of intermodal shipping containers shall be protected from decay and termites in accordance with the applicable provisions of Section 2304.12.1.1.

**3115.5 Under-floor ventilation.** The space between the bottom of the floor joists and the earth under any intermodal shipping container, except spaces occupied by basements and cellars, shall be provided with ventilation in accordance with Section 1202.4.

**3115.6 Roof assemblies.** Intermodal shipping container roof assemblies shall comply with the applicable requirements of Chapter 15.

**Exception:** Single-unit, stand-alone intermodal shipping containers not attached to, or stacked vertically over, other intermodal shipping containers, buildings or structures.

**3115.7 Joints and voids.** Joints and voids that create concealed spaces between intermodal shipping containers, that are connected or stacked, at fire-resistance-rated walls, floor or floor/ceiling assemblies and roofs or roof/ceiling assemblies shall be protected by an approved fire-resistant joint system in accordance with Section 715.

**3115.8 Structural.** Intermodal shipping containers that conform to ISO 1496-1 and are repurposed for use as buildings or structures, or as a part of buildings or structures, shall be designed in accordance with Chapter 16 and this section.

**3115.8.1 Foundations and supports.** Intermodal shipping containers repurposed for use as a permanent building or structure shall be supported on foundations or other supporting structures designed and constructed in accordance with Chapters 16 through 23.

**3115.8.1.1 Anchorage.** Intermodal shipping containers shall be anchored to foundations or other supporting structures as necessary to provide a continuous load path for all applicable design and environmental loads in accordance with Chapter 16.

**3115.8.1.2 Stacking.** *Intermodal shipping containers used to support stacked units shall comply with Section 3115.8.4.*

**3115.8.2 Welds.** *The strength of new welds and connections shall be no less than the strength provided by the original connections. All new welds and connections shall be designed and constructed in accordance with Chapters 16, 17 and 22.*

**3115.8.3 Structural design.** The structural design of the intermodal shipping containers repurposed for use as a building or structure, or as part of a building or structure, shall comply with Section 3115.8.4 or 3115.8.5.

**3115.8.4 Detailed structural design procedure.** A structural analysis meeting the requirements of this section shall be provided to the building official to demonstrate the structural adequacy of the intermodal shipping containers.

**Exception:** *Structures using an intermodal shipping containers designed in accordance with Section 3115.8.5.*

**3115.8.4.1 Material properties.** Structural material properties for existing intermodal shipping container steel components shall be established by *Section 2202.*



**3115.8.4.2 Seismic design parameters.** The seismic force-resisting system shall be designed and detailed in accordance with ASCE 7 and one of the following:

1. Where all or portions of the *profiled steel panel elements* are considered to be the seismic force-resisting system, design and detailing shall be in accordance with *AISI S100* and ASCE 7, Table 12.2-1 requirements for *systems not specifically detailed for seismic resistance, excluding cantilevered column systems*.
2. Where *all or portions of the profiled steel panel elements* are not considered to be *part of* the seismic force-resisting system, an independent seismic force-resisting system shall be selected, and detailed in accordance with ASCE 7, Table 12.2-1, or
3. Where *all or portions of the profiled steel panel elements* are retained and integrated into a seismic force-resisting system other than as permitted by *Section 3115.8.4.2* Item 1, seismic design parameters shall be developed from testing and analysis in accordance with Section 104.11 and ASCE 7, Section 12.2.1.1 or 12.2.1.2.

**3115.8.4.3 Allowable shear value.** The allowable shear values for the *profiled steel panel* side walls and end walls shall be *determined in accordance with the design approach selected in Section 3115.8.4.2*. Where penetrations are made in the side walls or end walls designated as part of the lateral force-resisting system, the penetrations shall be substantiated by rational analysis.

**3115.8.5 Simplified structural design procedure of single-unit containers.** Single-unit intermodal shipping containers conforming to the limitations of Section 3115.8.5.1 shall be permitted to be designed in accordance with Sections 3115.8.5.2 and 3115.8.5.3.

**3115.8.5.1 Limitations.** Use of Section 3115.8.5 is subject to all the following limitations:

1. The intermodal shipping container shall be a single-unit, stand-alone unit supported on a foundation and shall not be in contact with or supporting any other shipping container or other structure.
2. The intermodal shipping container's top and bottom rails, corner castings, and columns or any portion thereof shall not be notched, cut, or removed in any manner.

3. The intermodal shipping container shall be erected in a level and horizontal position with the floor located at the bottom.
4. The intermodal shipping container shall be located in Seismic Design Category A, B, C and D.

**3115.8.5.2 Simplified structural design assumptions.** Where permitted by Section 3115.8.5.1, single-unit stand-alone, intermodal shipping containers shall be designed using the following assumptions for the *profiled steel panel side walls* and end walls:

1. The appropriate detailing requirements contained in Chapters 16 through 23.
2. Response modification coefficient,  $R = 2$ .
3. Over strength factor,  $\Omega_0 = 2.5$ .
4. Deflection amplification factor,  $C_d = 2$ .
5. Limits on structural height,  $h_n = 9.5$  feet (2900 mm).

**3115.8.5.3 Allowable shear value.** The allowable shear values for the *profiled steel panel side walls* (longitudinal) and end walls (transverse) for wind design and seismic design using the coefficients of Section 3115.8.5.2 shall be in accordance with Table 3115.8.5.3, provided that all of the following conditions are met:

1. The total linear length of all openings in any individual side walls or end walls shall be limited to not more than 50 percent of the length of that side walls or end walls, as shown in Figure 3115.8.5.3(1).
2. Any full height wall length, or portion thereof, less than 4 feet (305 mm) long shall not be considered as a portion of the lateral force-resisting system, as shown in Figure 3115.8.5.3(2).
3. All side walls or end walls used as part of the lateral force-resisting system shall have an existing or new boundary element on all sides to form a continuous load path, or paths, with adequate strength and stiffness to transfer all forces from the point of application to the final point of resistance, as shown in Figure 3115.8.5.3(3). *The existing door interlocking mechanism shall not be considered as a component of the required load path.*

4. Where openings are made in container walls, floors or roofs, for doors, windows and other openings:
  - 4.1 The opening shall be framed with steel elements that are designed in accordance with Chapters 16 and 22.
  - 4.2 The cross section and material grade of any new steel element shall be equal to or greater than the steel element removed.
5. A maximum of one penetration not greater than a 6-inch (152 mm) diameter hole for conduits, pipes, tubes or vents, or not greater than 16 square inches (10 322mm<sup>2</sup>) for electrical boxes, is permitted for each individual 8 feet (2438 mm) length of lateral force-resisting wall. Penetrations located in walls that are not part of the wall lateral force resisting system shall not be limited in size or quantity. Existing intermodal shipping container's vents shall not be considered a penetration, as shown in Figure 3115.8.5.3(4).
6. End wall door or doors designated as part of the lateral force-resisting system shall be *intermittently welded closed\_around the full perimeters of the door panels.*

**TABLE 3115.8.5.3  
 ALLOWABLE SHEAR VALUES FOR STEEL PANEL  
 SIDE WALLS AND END WALLS FOR WIND OR SEISMIC LOADING**

CONTAINER DESIGNATION <sup>b</sup>	CONTAINER DIMENSION (Nominal Length)	CONTAINER DIMENSION (Nominal Height)	ALLOWABLE SHEAR VALUES (PLF) <sup>a,c</sup>	
			Side Wall	End Wall
1EEE	45 feet (13.7 M)	9.5 feet (2896 mm)	75	843
1EE		8.6 feet (2591 mm)		
1AAA	40 feet (12.2 M)	9.5 feet (2896 mm)	84	
1AA		8.5 feet (2592 mm)		
1A		8.0 feet (2438 mm)		
1AX		<8.0 feet (2483 mm)		
1BBB	30 feet (9.1 M)	9.5 feet (2896 mm)	112	
1BB		8.5 feet (2591 mm)		
1B		8.0 feet (2438 mm)		
1BX		<8.0 feet (2438 mm)		
1CC	20 feet (9.1 M)	8.5 feet (2591 mm)	168	
1C		8.0 feet (2438 mm)		
1CX		<8.0 feet (2438 mm)		

- a. The allowable shear *values* for the side walls and end walls of the intermodal shipping containers are derived from ISO 1496-1 and reduced by a factor of safety of 5.
- b. Container designation type is derived from ISO 668.
- c. Limitations of Sections 3115.8.5.1 and 3115.8.5.3 shall apply.

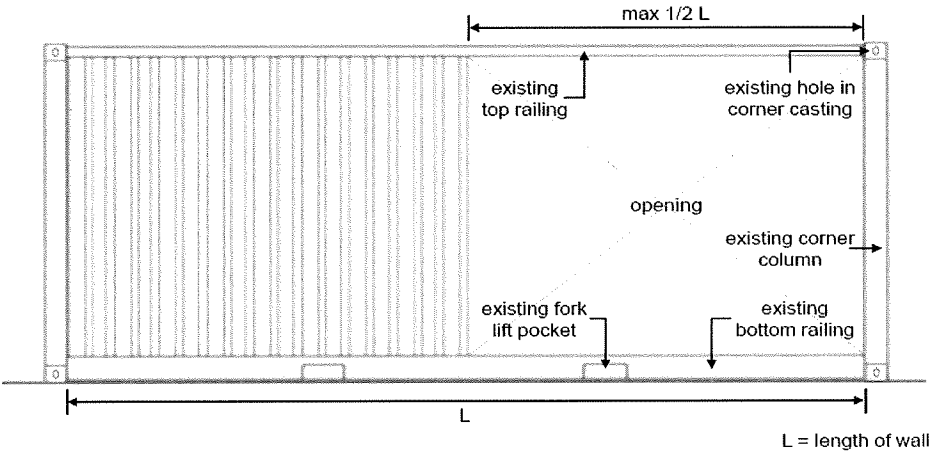

**FIGURE 3115.8.5.3(1)**  
**Bracing Unit Distribution – Maximum Linear Length**

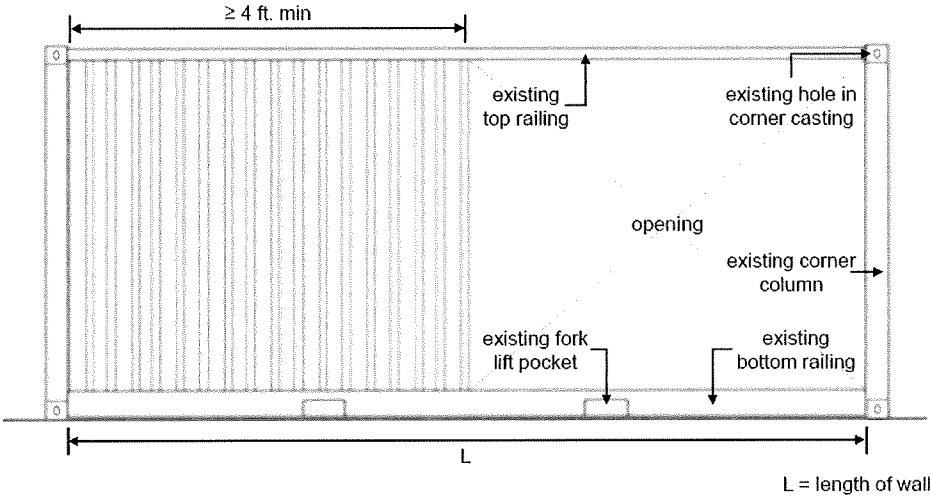

**FIGURE 3115.8.5.3(2)**  
**Bracing Unit Distribution – Minimum Linear Length**

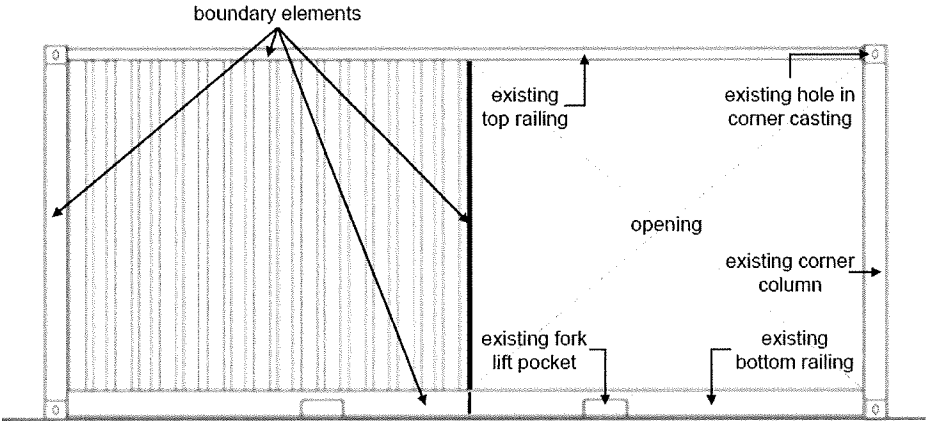

**FIGURE 3115.8.5.3(3)**  
**Bracing Unit Distribution – Boundary Elements**

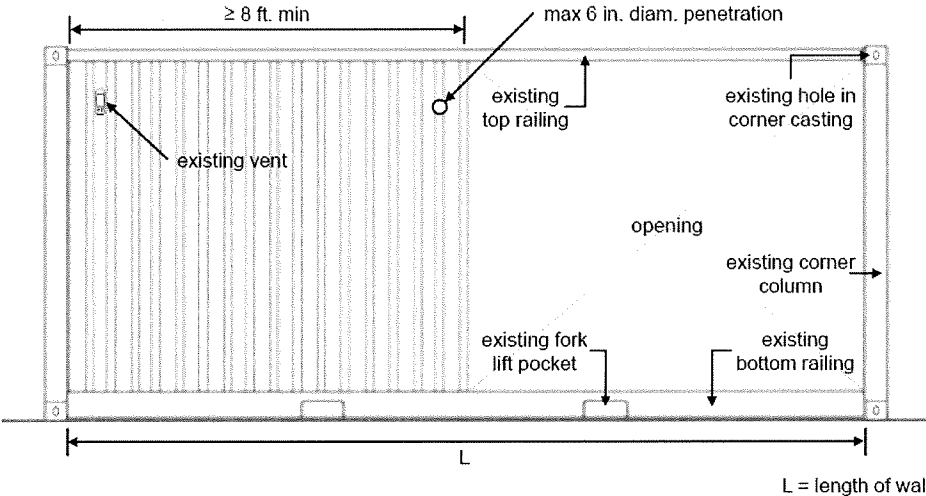

**FIGURE 3115.8.5.3(4)**  
**Bracing Unit Distribution – Penetrating Limitations**

ddd) Section J101.3 is added to Appendix J to read as follows:

**J101.3 Hazards.**

1. *Whenever the City Engineer determines that any land or any existing excavation or fill has, from any cause, become a menace to life or limb, or endangers public or private property, or adversely affects the safety, use or stability of public or private property, the owner of the property concerned shall, upon written notice thereof from the City Engineer (which shall be issued by first class mail), correct such condition in accordance with the provisions of this appendix and the requirements and conditions set forth in the notice (including deadlines for required actions) so as to eliminate such condition. The owner of the property shall immediately comply with the provisions set forth in the notice and shall complete all work to fully abate the condition within 180 days from the date of the notice unless a shorter period of time for completion has been specified in the notice in which case the owner shall comply with the shorter period of time. Upon written application and good cause shown, the City Engineer may, provided he/she concludes good cause exists, approve the request for an extension of time to complete the work required by the notice. A notice to the owner shall include a statement that a missed deadline, or untimely compliance with requested actions, may result in the City of Agoura Hills recording a certificate of substandard property with the Office of the Los Angeles County Recorder's Office. "Owner" is the person who appears as such in Los Angeles County Assessor records for a property, and other persons, if known to the City Engineer, who are in control of, or responsible, for a property. A notice shall be sent to an owner to his/her/its address as shown on the last equalized assessment roll for a property. Where the City Engineer knows of other persons who are in control of, or responsible for, a property, the City Engineer shall send a copy of a notice to the address set forth in records of the Public Works Department for such persons. Failure of an owner or other persons to receive a notice shall not relieve them from the obligation to comply with this appendix.*

2. *If the above condition is not fully eliminated within the specified time period, or if the owner has missed a deadline in the notice (including without limitation for obtaining a grading permit) the City Engineer may file with the Office of the Los Angeles County Recorder a certificate stating that the property is deemed substandard and that the owner thereof has been so notified. The certificate shall describe the condition that renders the property substandard. The City Engineer shall, by first class mail, send a copy of the certificate for recording to the owner.*

3. *When the above condition has been fully corrected to the satisfaction of the City Engineer, he/she shall file with the Office of the Los Angeles County Recorder, within a period of time not exceeding thirty (30) days, a certificate specifying that the condition has been fully corrected and that the property is no longer substandard. The City Engineer shall by first class mail, send a copy of the certificate for recording to the owner.*

eee) Section J101.4 is added to Appendix J to read as follows:

### **J101.4 Safety Precautions**

#### **1. General**

a) *If at any stage of work on an excavation or fill, the City Engineer determines that the work has become or is likely to become dangerous to any person, or is likely to endanger any property, public or private, the City Engineer must be authorized to require safety precautions to be immediately taken by the property owner as a condition to continuing such permitted work or to require cessation thereof forthwith unless and until it is made safe and to amend the plans for such work.*

b) *Safety precautions may include, without limitation, specifying a flatter exposed slope or construction of additional drainage facilities, berms, terracing, compaction, cribbing, retaining walls or buttress fills, slough walls, desilting basins, check dams, benching, wire mesh, and guniting, rock fences, revetments or diversion walls.*

c) *Upon the determination of the City Engineer that such safety precautions during grading are necessary, the City Engineer shall provide a notice and order to the permittee to implement same. After receiving such notice, oral or written, it is unlawful for the permittee or any person to proceed with such work contrary to such order.*

#### **2. Maintenance of Ground Cover**

a) *Existing groundcover in any hillside area that is not affected by an issued grading permit shall be maintained in a healthful condition at all times and shall not be destroyed or removed. As used herein, "groundcover" means plants that cover ground and that provide protection of the topsoil from erosion and drought. As used herein, "destroyed" includes, without limitation, any actions or inaction that cause, or will likely cause or contribute to, such groundcover dying or existing in an unhealthful condition in the future. As used herein, "maintained in a healthful condition" includes, without limitation, proper watering and fertilization and cutting or trimming that does not cause or contribute to the death of groundcover or cause it to exist in an unhealthful condition in the future. Cutting or trimming actions that result in groundcover dying or that cause or contribute to groundcover existing in an unhealthful condition in the future are unlawful and prohibited. This subpart does not apply to groundcover that the Los Angeles County Fire Department requires to be destroyed or removed in the enforcement of the Fire Code. In the event the City Engineer determines a violation of this subpart has occurred, the owner of the affected hillside area shall, upon written notice thereof by the City Engineer via first class mail, obtain written approval from the City Engineer within forty-five (45) days of the date of the notice for proposed replacement groundcover. The owner shall complete*

*installation of the approved groundcover and obtain a final inspection approval in writing from the City Engineer within thirty (30) days thereafter. An owner's failure to obtain timely written approvals from the City Engineer are violations of this subpart and unlawful. As used herein, "owner" is the person who appears as such in Los Angeles County Assessor records for a property. A notice shall be sent to an owner to his/her/its address as shown on the last equalized assessment roll for a property.*

*b) Whenever groundcover on private real property is removed or damaged as a result of action or actions undertaken pursuant to an issued grading permit, the owner of that property and permittees under that permit shall restore the affected area with new groundcover as approved and required by the City Engineer and shall complete such other erosion control protection measures or installations as may be required by the City Engineer. The owner or his/her/its permittee under that permit shall obtain written approval of the City Engineer for newly installed groundcover and for any required erosion control protection measures or installations as a condition to obtaining a final inspection approval of a grading from the City Engineer. It is unlawful and a violation of this subpart for an owner to fail to install new groundcover and/or complete other required protection measures or installations in a period of time required by the City Engineer. It is also unlawful and a violation of this subpart for an owner to fail to maintain installed protection measures or installations in a good and effective condition and in good repair at all times in the future. Following the City Engineer's approval of new groundcover, an owner shall be subject to Subpart A. of this section. As used herein, "damaged" means groundcover that has, or will likely, die or become or remain unhealthful because of, or in part due to, an action or actions that were undertaken pursuant to an issued grading permit.*

### *3. Maintenance of Protective Structures/Devices/Installations*

*All structures/devices/installations used to protect hillside areas from erosion or landslide damage including, without limitation, retaining walls, cribbing, terracing, surface and subsurface drainage structures, interceptor drains, check dams, and riprap shall be maintained in good condition and repair at all times.*

fff) Section J101.5 is added to Appendix J to read as follows:

***J101.5 Protection of Utilities.*** *The owner of any property for which a grading permit has been issued, and permittees, shall in the course of undertaking actions pursuant to that permit, prevent damage to public utilities or services.*

ggg) Section J101.6 is added to Appendix J to read as follows:

***J101.6 Protection of Adjacent Properties.*** *The owner of any property for which a grading permit has been issued, and permittees, shall in the course of undertaking*



*actions pursuant to that permit, prevent damage to adjacent property. Furthermore, no owner or permittee shall excavate on land sufficiently close to the property line to endanger any adjoining public street, sidewalk, alley, or other public or private property without first obtaining written approval of the City Engineer for protections to said public or private properties against settling, cracking or other damage and completing the installation of those protections prior to undertaking the excavation.. Special precautions approved by the City Engineer shall also be made to prevent imported or exported materials from being deposited on the adjacent public way and/or drainage courses. A 30-day excavation notice shall be provided as required by California Civil Code Section 829-834 when the excavation is of sufficient depth and proximity to adjacent lot structures.*

hhh) Section J101.7 is added to Appendix J to read as follows:

***J101.7 Storm-water control measures.*** *The owner of any property for which a grading permit has been issued and permittees shall put into effect and maintain all measures and installations necessary to protect adjacent water courses and public and private property from damage by erosion, flooding, and deposition of mud, debris and construction-related pollutants originating from the site during, and after, grading and related construction activities. Furthermore, the owner and permittees shall implement, install and maintain measures and installations necessary to prevent any change in cross-lot surface drainage that may adversely affect any adjoining property as a result of grading and/or construction-related activities. Such measures and and installations to prevent any adverse cross-lot surface drainage effects on adjoining property shall be required whether shown on approved grading plans or not..*

iii) Section J101.8 is added to Appendix J to read as follows:

***J101.8 Conditions of approval.*** *In granting any permit under this code, the City Engineer may impose such conditions on a permit as he/she believes reasonably necessary to protect public health, safety, or welfare and/or to prevent or protect against any hazard that could be posed to a person or to persons or to public or private property in the absence of a permit condition or conditions. It is unlawful and a violation of this subpart for an owner to not comply with a permit condition. Such conditions may include, but shall not be limited to:*

*1. Improvement of any existing grading to comply with the current standards of this code.*

*2. Requirements for fencing of excavations or fills which would otherwise be hazardous.*

jjj) Section J101.9 is added to Appendix J to read as follows:

***J101.9 Other regulations.***

**J101.9.1 Waiver.** *The permissive provisions of this chapter shall not be presumed to waive any regulations or statutes imposed by the State of California or other regulations of the City of Agoura Hills Municipal Code.*

**J101.9.2 More restrictive regulations.** *If two or more pertinent regulations are not identical, those regulations shall prevail which are more restrictive, or which afford greater safety to life, limb, health, property or welfare. For the purposes of these regulations, grading permits shall be considered as building permits and shall be subject to the same administrative provisions of this code, unless otherwise specifically provided for in this chapter.*

kkk) Section J103.2 is amended to Appendix J to read as follows:

**J103.2 Exemptions.** *A grading permit shall not be required for the following. No exemptions shall relieve the requirements set forth by the Building Official to address drainage and water quality concerns.*

1. *When approved in writing by the City Engineer, grading in an isolated, self-contained area, provided there is no danger to the public, and that such grading will not adversely affect adjoining properties or any public property.*
2. *Excavation for construction of a structure permitted under this code where the excavation is limited to within the footprint of the proposed structure and not exceeding 5 feet in depth.*
3. *Cemetery graves.*
4. *Refuse disposal sites controlled by other regulations.*
5. *Excavations for wells, or trenches for utilities.*
6. *Mining, quarrying, excavating, processing or stockpiling rock, sand, aggregate or clay controlled by other regulations, provided such operations do not affect the lateral support of, or significantly increase stresses in, soil and adjoining properties.*
7. *Exploratory excavations performed under the direction of a registered soils engineer or engineering geologist. This shall not exempt grading of access roads or pads created for exploratory excavations, which require a permit from the City Engineer. Exploratory excavations must not create a hazardous condition to adjacent properties or the public in accordance with Section J101.3. Exploratory excavations must be restored to pre-existing conditions, unless approved by the City Engineer in writing.*

lll) Section J103.3 is added to Appendix J to read as follows:

**J103.3 Permit issuance.**

1. *The issuance of a grading permit shall constitute an authorization to do only that work which is described or illustrated on the application for the permit and on the grading plans and specifications approved by the City Engineer at the time of issuance.*

2. *Jurisdiction of other agencies. Permits issued under the requirements of this appendix shall not relieve the owner of responsibility for securing required permits for work to be accomplished that is regulated by any other code, department, or division of the City of Agoura Hills. Furthermore, permits issued pursuant to this appendix shall not relieve an owner from securing approvals and/or permits as may be required by Los Angeles County and the State of California.*

3. *Conditions of permit. The City Engineer, upon recommendation of the city traffic and transportation administrator, may impose such conditions with respect to access routes to and from grading sites in hillside areas as the City Engineer shall determine are required in the interest of safety precautions involving pedestrian or vehicular traffic. This is in addition to conditions imposed pursuant to Section J101.8. . It is unlawful to not comply with a permit condition.*

4. *Consent of adjacent property owner. Whenever any excavation or fill or other grading-related work requires entry onto adjacent property for any reason, the permit applicant shall obtain the written consent of the adjacent property owner or their authorized representative, and shall tender a signed and duly notarized copy of such consent with the City Engineer prior to the issuance of a permit. The consent form shall be approved by the City Attorney and the statements therein shall be acceptable to the City Engineer. If a permit applicant claims an easement authorizes entry onto adjacent property in connection with proposed grading-related work, the applicant shall tender a recorded copy of the easement to the City Engineer prior to the issuance of a permit. In addition to tendering a consent form and/or an easement, the owner of real property for which a grading permit is sought, shall execute an indemnification/hold harmless form in favor of the City of Agoura Hills as approved by the City Attorney and tender the completed/executed form to the City Engineer prior to the issuance of a grading permit.*

5. *Unpermitted Actions. If grading and/or other actions regulated by this appendix occur without a grading permit, a subsequently obtained permit shall automatically expire and become null and void ninety (90) calendar days after the date on which the permit was issued. The City Engineer may extend the validity of the permit for a period not exceeding ninety (90) calendar days beyond the initial ninety (90) day limit upon written request by the applicant filed with the City Engineer prior to the expiration date of the original permit. The applicant shall show justifiable cause in the extension request, which City Engineer must find to be satisfactory before granting an extension.*

6. *Time limitation of application and expiration of permit. Time limitation of application and expiration of permit shall be governed by the amended CBC Sections 105.3.2.1 and 105.5 and CRC Sections R105.3.2.1 and R105.5.*

mmm) Section J103.4 is added to Appendix J to read as follows:

**J103.4 Grading fees.**

- 1. Fees for grading plan check and for grading permits shall be established or modified by resolution of the city council. The schedule of such fees shall remain on file and be available in the office of the City Engineer. The City Engineer shall, with the approval of the city manager, recommend changes in fee amounts to the council when the costs to provide grading plan check and grading inspection services make it appropriate.*
- 2. The applicant shall pay a plan check fee prior to acceptance of grading plans and specifications for checking by the city. Plans shall not be reviewed prior to the City Engineer's receipt of the entire fee.*
- 3. Whenever the applicant submits a grading plan for plan check that is substantially different, as determined by the City Engineer, in design of the earthwork as compared to previously submitted grading plans, the submittal shall be considered an original and a new grading plan check fee shall be determined and paid to the city as provided in this section.*
- 4. The applicant shall pay a grading permit fee prior to the issuance of a grading permit by the city. If, during grading operations, the plans and specifications for the grading project are revised increasing the scope of the project that was used to determine the grading permit fee, the applicant shall pay to the city the difference between the original grading permit fee and the recalculated fee before work may resume under the grading permit.*
- 5. Whenever grading operations are commenced without an approved grading permit, an investigation fee shall be added to all unpaid fees for grading plan check and grading permits. The investigation fee shall be one hundred percent of all fees due the city.*

nnn) Section J104.2.1 is added to Appendix J to read as follows:

**J104.2.1 Grading Designation.** *Grading in hilly terrain areas involving slope greater than 33% and all grading in excess of 250 cubic yards shall be performed in accordance with the approved grading plan prepared by a registered civil engineer, and shall be designated as "engineered grading." Grading involving less than 250 cubic yards and not located in an area of hilly terrain area involving slope greater than 33% shall be designated as "regular grading" unless the permittee chooses to have the grading performed as engineered grading, or the City Engineer determines that special conditions or unusual hazards exist, in which case grading shall conform to the requirements for engineered grading.*

ooo) Section J104.2.2 is added to Appendix J to read as follows:

**J104.2.2 Regular grading requirements.** *In addition to the provisions of Section 106, and Section 104.2, Chapter 1, Division II, an application for a regular grading permit shall be accompanied by plans in sufficient clarity to indicate the nature and extent of the work. The plans shall give the location of the work, the name of the owner, and the name of the person who prepared the plan. If the slope of the grade exceeds 3 units horizontal to 1 unit vertical or as required by the City Engineer, the plans and specifications shall be prepared and signed by an individual licensed by the state to prepare such plans or specifications. The plan shall include the following information:*

- 1. General vicinity of the proposed site.*
- 2. Limits and depths of cut and fill.*
- 3. Location of any buildings or structures where work is to be performed, and the location of any buildings or structures within 15 feet (4.6 m) of the proposed grading.*
- 4. Contours, flow areas, elevations, or slopes that define existing and proposed drainage patterns.*
- 5. Stormwater provisions in accordance with the requirements of Appendix J and Chapter 5 of Article V of the City of Agoura Hills Municipal Code.*
- 6. Location of existing and proposed utilities, drainage facilities, and recorded public and private easements and use restricted use areas.*
- 7. Recommendations in the geotechnical engineering report and the engineering geology report shall be incorporated into the grading plans or specifications. When approved by the City Engineer, specific recommendations contained in the geotechnical engineering report and the engineering geology report, that are applicable to grading, may be included by reference.*
- 8. Location of all Special Flood Hazard Areas as designated and defined in Title 44, Code of Federal Regulations.*

ppp) Section J104.2.3 is added to Appendix J to read as follows:

**J104.2.3 Engineered grading requirements.** *In addition to the provisions of Chapter 1 Division II, Section 107 and Appendix J Section J 104.2, an application for an engineered grading permit shall be accompanied by plans and specifications, and supporting data consisting of a soils engineering report and engineering geology report. The plans and specifications shall be prepared and signed by an individual licensed by the state to prepare such plans or specifications when required by the City Engineer. Specifications shall contain information covering structures and material requirements. Plans shall be drawn to scale and shall be of sufficient clarity to indicate the nature and extent of the work proposed and show in detail that it will conform to the provisions of this code and all relevant laws, ordinances, rules, and*

*regulations. The first sheet of each set of plans shall give location of the work, the name and address of the owner, and the person by whom they were prepared. The plans shall include, but shall not be limited to, the following information:*

- 1. General vicinity of the proposed site.*
- 2. Property limits and accurate contours of existing ground and details of terrain and area drainage.*
- 3. Limiting dimensions, elevations, or finish contours to be achieved by the grading, proposed drainage channels, and related structures.*
- 4. Detailed plans of all surface and subsurface drainage devices, walls, cribbing, dams and other protective devices to be constructed with, or as a part of, the proposed work. A map showing the drainage area and the estimated runoff of the area served by any drains shall also be provided.*
- 5. Location of any existing or proposed buildings or structures on the property where the work is to be performed and the location of any buildings or structures on land of adjacent owners that are within 15 feet (4.6 m) of the property or that may be affected by the proposed grading operations.*
- 6. Recommendations in the geotechnical engineering report and the engineering geology report shall be incorporated into the grading plans or specifications. When approved by the City Engineer, specific recommendations contained in the geotechnical engineering report and the engineering geology report, that are applicable to grading, may be included by reference.*
- 7. The dates of the geotechnical engineering and engineering geology reports together with the names, addresses, and telephone numbers of the firms or individuals who prepared the reports.*
- 8. A statement of the earthwork quantities of materials to be excavated and/or filled. Earthwork quantities shall include quantities for geotechnical and geological remediation. In addition, a statement of material to be imported or exported from the site.*
- 9. A statement of the estimated starting and completion dates for work covered by the permit.*
- 10. A statement signed by the owner acknowledging that a field engineer, geotechnical engineer and engineering geologist, when necessary in the judgment of the City Engineer, shall be employed by the owner to perform the services required by this code, or whenever approval of the plans and issuance of the permit are to be based on the condition that such professional persons be so employed. These acknowledgments shall be on a form furnished by the City Engineer*

11. Storm water provisions are required to be shown on the grading plan in accordance with Appendix J and Chapter 5 of Article V of the AHMC

12. A drainage plan for that portion of a lot or parcel to be utilized as a building site (building pad), including elevation of floors with respect to finish site grade and locations of existing and proposed stoops, slabs, fences or other features that may affect drainage.

13. Location and type of any existing or proposed private sewage disposal system.

14. Location of existing and proposed utilities, drainage facilities, and recorded public and private easements.

15. Location of all recorded floodways.

16. Location of all Special Flood Hazard Areas as designated and defined in Title 44, Code of Federal Regulations.

qqq) Section J105.3 is added to Appendix J to read as follows:

**J105.3 Responsibility.** *The permittee and owner shall be responsible for ensuring that the grading is performed in accordance with the approved plans and specifications and in conformance with the provisions of this Code. The permittee and owner shall engage project consultants, if required under the provisions of this Code, to provide professional inspections on a timely basis. The permittee shall act as a coordinator between the project consultants, the contractor and the City Engineer. In the event of changed conditions, the permittee shall be responsible for informing the City Engineer of such change and shall provide revised plans for approval in a period of time established by the City Engineer.*

rrr) Section J105.4 is added to Appendix J to read as follows:

**J105.4 Required inspections.** *The permittee shall call for an inspection by the City Engineer at the following various stages of work and shall obtain the written approval of the City Engineer prior to proceeding to the next stage of work:*

*Pre-grade. Before any construction or grading activities occur at the site. Permittee shall schedule a pre-grade inspection with the City Engineer. The permittee shall ensure that all project consultants are present at the pre-grade inspection.*

*Initial grade. When the site has been cleared of vegetation and unapproved fill and has been scarified, benched, or otherwise prepared for fill. No fill shall have been placed prior to this inspection.*

*Rough grade. When approximate final elevations have been established, drainage terraces, swales, and other drainage devices necessary for the protection of the*

*building sites from flooding have been installed, berms have been installed at the top of the slopes, and the statements of completion have been received.*

*Final grade. When grading has been completed, all drainage devices necessary to drain the building pad have been installed, slope planting has been established, irrigation systems have been installed, and the as-built plans and required statements and reports have been submitted.*

sss) Section J109.5 is added to Appendix J to read as follows:

**J109.5 Disposal.** *All drainage facilities shall be designed to carry waters to the nearest practicable street, storm drain, or natural watercourse drainage way approved by the City Engineer or other appropriate governmental agency jurisdiction provided it is a safe place to deposit such waters. Erosion of ground in the area of discharge shall be prevented by installation of non-erosive down drains or other devices. Desilting basins, filter barriers or other methods, as approved by the City Engineer, shall be utilized to remove sediments from surface waters before such waters are allowed to enter streets, storm drains, or natural watercourses. If the drainage device discharges onto natural ground, riprap or a similar energy dissipater may be required. Building pads shall have a minimum drainage gradient of 2 percent toward approved drainage facilities, a public street or drainage structure approved to receive storm waters unless waived by the City Engineer. A lesser slope may be approved by the City Engineer for sites graded in relatively flat terrain, or where special drainage provisions are made, when the City Engineer finds such modification will not result in unfavorable drainage conditions.*

ttt) Section J112 is added to Appendix J to read as follows:

**J112 National Pollutant Discharge Elimination System (NPDES) Compliance.** *All grading plans and permits shall comply with the provisions of this section for NPDES compliance including the owner of any property on which grading has been performed and which requires a grading permit under Appendix J Section J103. Sites which have been graded and which require a grading permit under Appendix J Section J103 are subject to penalties and fines. All best management practices shall be installed before grading begins or as instructed in writing by the City Engineer for unpermitted grading as defined by Section J 103.3. As grading progresses, all best management practices shall be updated as necessary to prevent erosion and control structures related pollutants from discharging from the site. All best management practices shall be maintained in good working order to the satisfaction of the City Engineer unless final grading approval has been granted by the City Engineer and all permanent drainage and erosion control systems, if required, are in place.*

uuu) Section P103.1 is amended to Appendix P to read as follows:

**P103.1 General.** *Emergency sleeping cabins, emergency transportable housing units, membrane structures and tents constructed and/or assembled in accordance with this*



appendix, shall be occupied only during declaration of state of emergency, local emergency, or shelter crisis, *and authorized by the City Council.*

Buildings and structures constructed in accordance with the California Building Standards Code, used as emergency housing, shall be permitted to be permanently occupied.

## **8202.5 California Residential Code Adopted with Local Amendments**

### A. Adoption of California Residential Code, 2022 Edition.

Pursuant to California Government Code § 50022.2, the California Residential Code, 2022 Edition, published as Title 24, Part 2.5, of the California Code of Regulations, including Appendix AQ (Tiny Houses), Appendix AX (Swimming Pool Safety Act), and Appendix AZ (Emergency Housing) (“CRC”) is adopted by reference, subject to the amendments, additions and deletions set forth below.

One true copy of the CRC is on file in the office of the Building Official and is available for public inspection as required by law.

### B. Amendments to the California Residential Code.

#### a) Second paragraph of Section 1.8.8.1 is amended to read as follows:

*The City Council shall serve as the local appeals board or housing appeals board as specified in California Health and Safety Code Sections 17920.5 and 17920.6.*

#### b) Section 1.8.8.4 is added to read as follows:

**1.8.8.4 Limitation of Authority.** The Local Appeals Board and the Housing Appeals Board shall not have jurisdiction to consider, decide or rule on whether persons are responsible or not responsible for violations and public nuisances of the Agoura Hills Municipal Code, as well as on actions that are required by the City of responsible persons to correct or otherwise abate violations and/or public nuisances.

This limitation of authority shall also apply to any board that is established by the 2022 Residential, Electrical, Mechanical, Plumbing, Energy, Fire, Existing Building and Green Building Standards Codes, as adopted by the city.

#### c) Section R101.1 is amended to read as follows:

**R101.1 Title.** These regulations shall be known as the *Residential Code of the City of Agoura Hills*, hereinafter referred to as “this code”.

#### d) Section R103.3 is amended to read as follows:

**R103.3 Deputies.** In accordance with the prescribed procedures of this jurisdiction and with the concurrence of the appointing authority, the building official shall have the authority to appoint a deputy building official, the related technical officers, inspectors, plan examiners and other employees. Such employees shall have powers as delegated by the building official.

- e) Section R105.1 is amended to read as follows:

**R105.1 Required.** *All persons who intend to construct, enlarge, alter, move, demolish or change the occupancy of a building or structure, or to erect, install, enlarge, alter, repair, remove, convert or replace any electrical, gas, mechanical or plumbing system, component or device, the installation of which is regulated by the Technical Codes in Article VIII of the Agoura Hills Municipal Code, shall first make written application to the building official and obtain each required permit.*

*No person shall undertake or cause grading to occur on land without the prior procurement of a grading permit unless such grading is exempt from a permit as provided for in Section 103.2 of Appendix J.*

*Whenever any work or installation or grading has been commenced without a permit in violation of this section, a Stop Work Order shall immediately be issued by the Building Official and a special investigation to identify the nature and extent of the unpermitted work or installation shall be made. Based on the findings of the investigation, conditions may be given to the violator to correct any unpermitted conditions to the satisfaction of the Building Official prior to the issuance of the permit and to continue work. An investigation fee shall be paid in addition to customary fees for each permit which the work had started prior to, or at the time of, the issuance of a permit or permits. Failure to pay a special investigation fee in full constitutes cause to deny the issuance of a permit or permits. The investigation fee shall be as specified by resolution of the City Council.*

*The payment of the investigation fee shall not exempt any person from compliance with all other provisions of the Agoura Hills Municipal Code, or from any penalty prescribed by law for failing to obtain each required permit.*

- f) Section R105.2 under **Building** - items 1 through 13 are amended, and items number 14 thru 18 are added; under **Electrical** - item 6 is added; and a new category titled **Grading** is added to read as follows:

**Building:**

1. One story detached accessory buildings or structures used as tool and storage sheds, shade structure, playhouses or similar uses that are accessory to detached one and two family dwellings, and similar uses, provided the floor area does not exceed 120 square feet and are not more than 14 feet in height

*above adjacent grade. It is permissible that these structures still be regulated by Section 710A, despite exemption from permit.*

2. Fences, *other than masonry or concrete, not over 6 feet high, measured from finished grade immediately adjacent to the fence, to top of the finished fence.*
3. Oil derricks.
4. *Retaining walls or masonry/concrete wall less than 2 feet in height measured from grade immediately adjacent to the wall to the top of the wall, and not supporting a surcharge.*
5. Water tanks supported directly on grade if the capacity is not greater than 5000 gallons and the ratio of height to diameter or width is not greater than 2:1.
6. Sidewalks, driveways, *platforms and walkways* associated with one and two family dwellings, not more than 30 inches above grade at any point and not located over any basement or story below, nor supporting any structure above and are not part of an accessible route.
7. Painting, papering, tiling, carpeting, cabinets, counter tops and similar finish work.
8. *Temporary motion picture, television and theater stage sets and scenery structures that are erected and maintained for a specific period of time in connection with a filming permit that is issued pursuant to Article VI, Chapter 6 of the Agoura Hills Municipal Code. Electrical installations (including the use of generators) and gas installations for sets and structures require a permit before they occur.*
9. Prefabricated swimming pool accessory to a Group R-3 Occupancy that are less than 18 inches deep, do not exceed 5,000 gallons and are installed entirely above ground.
10. Shade cloth structures constructed for nursery or agricultural purposes, not including service systems.
11. Swings and other playground equipment accessory to detached one and two family dwellings.
12. Window awnings supported by an exterior wall in group R-3 and U occupancies, *that are less than 12 square feet of shade cover and do not project more than 48 inches from exterior wall* and do not require additional support.
13. Non-fixed and movable fixtures, cases, racks, counters and partitions not over 5 feet 9 inches in height.

14. *Detached one story shade covers for animals when the covers are not over 12 feet in height above adjacent grade, not more than 400 feet of roof area and open on 3 sides minimum.*
15. *Readily removable plastic covered hoop structures, with maximum 12' in height with no in-ground footings or foundation.*
16. *Replacement of residential exterior door when the doorframe is not removed.*
17. *Replacement of kitchen appliance with similar appliance in same location. This exception does not apply if the work includes opening the walls or replacing or altering the plumbing or electrical systems.*
18. *Flagpoles that are 20 feet or less in height above finish grade when fully extended.*

**Electrical:**

6. *Removal of abandoned electrical wiring and conduits. "Abandoned" means such wiring and conduits that are not energized.*

**Grading:**

1. *All grading that is exempt from a permit shall be pursuant to Section 103.2 of Appendix "J" of the California Building Code or other reference codes accepted by the Building Official.*

g) Section R105.3.2 is amended to read as follows:

**R105.3.2 Time limitation of application.** *Unless extended or reinstated as provided herein, an application for permit is deemed abandoned if an applicant has not satisfied all requirements for a permit for proposed work or actions within twelve (12) months of tender of an application to the Building and Safety Division. The Building Official is authorized to grant one or more extensions of time for additional periods not exceeding ninety (90) days each to complete all requirements for a permit. An applicant seeking an initial extension shall tender a request to the Building Official prior to the date the application is deemed abandoned. In order to be eligible for any further extensions, an applicant shall tender a subsequent request or requests to the Building Official before a prior extension period expires. Each extension request shall be requested in writing and justifiable cause demonstrated, as determined by the Building Official.*

*When an application has been deemed abandoned, a permit shall not be issued prior to the application being reinstated or a new application tendered with new fees paid. Requests to reinstate an application that has been deemed abandoned shall be submitted to the Building Official, in writing, demonstrating justifiable cause and are*

*subject to the approval of the Building Official. If approved by the Building Official, the fee shall be one half (1/2) of the amount of the original plan review fee, provided that the period of time following the Building Official's date of determination of abandonment of the original application has not exceeded six (6) months, no changes have been made or will be made in the original submittal and the construction codes under which the original application was submitted are the same as the current construction codes in effect. To reinstate a application when the period of time following the Building Official's date of determination of abandonment of the original application has exceeded six (6) months; or changes have been made or will be made in the original submittal; or current construction codes are different from those construction codes under which the original application was submitted, the permittee shall be required to pay a new full permit fee and that person shall comply with all construction codes in effect on the date of the new permit application.*

h) Section R105.3.2.1 is added to read as follows:

**R105.3.2.1 Time limitation of application in connection with an unpermitted structure.** *Unless extended or reinstated as provided herein, an application for a permit is deemed abandoned if an applicant has not satisfied all requirements for a permit in connection with an unpermitted structure as defined in Section R110.1.1 of this code within ninety (90) calendar days of tender of an application therefor to the Building and Safety Division. The Building Official is authorized to grant one or more extensions of time for additional periods not exceeding thirty (30) days each to complete all requirements for a permit. An applicant seeking an initial extension shall tender a request to the Building Official prior to the date the application is deemed abandoned. In order to be eligible for any further extensions, an applicant shall tender a subsequent request or requests to the Building Official before a prior extension period expires. Each extension request shall be requested in writing and justifiable cause demonstrated, as determined by the Building Official.*

i) Section R105.5 is amended to read as follows:

**R105.5 Expiration of permit.** *Unless extended or reinstated as provided herein, every permit issued, except those under Subsection R105.5.2, shall be deemed suspended or abandoned and shall automatically expire and become null and void unless the permittee completes at least twenty percent (20%) of the total work or actions authorized by a permit (as determined by the Building Official) for Group R-3 Occupancies, and at least ten percent (10%) of the total work or actions authorized by a permit (as determined by the Building Official) for all other occupancies, and the permittee obtains a successful inspection from the Building Official within the first twelve (12) months from the permit's issuance date. An issued permit shall also be deemed suspended or abandoned and shall automatically expire and become null and void if the permittee does not complete at least an additional twenty percent (20%) of the total work or actions authorized by a permit (as determined by the Building Official) for Group R-3 Occupancies, and at least an additional ten percent (10%) of the total work or actions authorized by a permit (as determined by the Building Official)*

*for all other occupancies, and the permittee obtains a subsequent successful inspection within twelve (12) months from a prior successful inspection. A successful inspection is defined as an inspection that is required by Section 110 of Chapter 1, Division II of the 2022 California Building Code (as adopted by Section 8100 of the Agoura Hills Municipal Code), during which the Building Official or a designee thereof determined that the inspected work or actions met all applicable minimum code requirements and he/she approved and documented that work as successful. Notwithstanding prior timely successful inspections, a permit shall automatically expire and become null and void if the permittee does not obtain a final inspection approval from a building inspector for completion of all work or actions authorized by a permit as follows: (i) within three (3) years from the date of issuance of a permit having a valuation of less than \$250,000.00; (ii) within four (4) years from the date of issuance of a permit having a valuation of between \$250,000.00 and \$1,000,000.00; and, (iii) within five (5) years from the date of issuance of a permit having a valuation of more than \$1,000,000.00.*

*The Building Official may grant one (1) extension of a permit for a period not exceeding one hundred eighty (180) days, provided he/she receives a written request stating justifiable cause, prior to the expiration date of a permit. The Building Official may deny the request for a permit extension if her/she determines that justifiable cause was not shown in the request.*

*When a permit that was issued pursuant to Section R105.1 has expired, work shall not recommence prior to obtaining a new permit, which shall be subject to Section R105.5.2 of this code. Requests to reinstate an expired permit shall be submitted to the building official, in writing, demonstrating justifiable cause and are subject to the approval of the building official. If approved by the Building Official, the fee shall be one half (1/2) of the amount of the original permit fee, provided that the expiration period of the original permit has not exceeded six (6) months, no changes have been made or will be made in the original approved plans and specifications, and the construction codes under which the original permit was issued are the same as the current construction codes in effect. To reinstate a permit when the expiration period of the original permit has exceeded six (6) months; or changes have been made or will be made in the original approved plans and specifications; or current construction codes are different from those construction codes under which the original permit was issued the permittee shall be required to pay a new full permit fee and that person shall comply with all construction codes in effect on the date of the new permit application.*

- j) Section R105.5.1 is amended to read as follows:

**R105.5.1 Expiration.** *Every permit issued before January 1, 2019 that did not automatically expire and become null and void by December 31, 2022 pursuant to the code then in effect shall be deemed abandoned and shall automatically expire and be null and void if the permittee does not thereafter obtain a subsequent successful inspection within 180 days from a prior successful inspection. A successful inspection*

*is defined as an inspection that is required by Section 110 of Chapter 1, Division II of the 2022 California Building Code (as adopted by Section 8100 of the Agoura Hills Municipal Code), during which the Building Official or a designee thereof determined that the inspected work or actions met all applicable minimum code requirements and he/she approved and documented that work as successful. The Building Official may grant one extension of a permit subject to this subsection for a period not exceeding 180 days, provided he/she receives a written request stating justifiable cause, prior to the expiration date of the permit. The Building Official may deny the request for a permit extension if her/she determines that justifiable cause was not shown in the request.*

*When a permit subject to this subsection has expired, work shall not recommence prior to obtaining a new permit, which shall be subject to Section R105.5.2 of this code. Payment of a full permit fee is required.*

k) Section R105.5.2 is added to read as follows:

***R105.5.2 Expiration of permit in connection with an unpermitted structure.*** *Notwithstanding Section 105.5 or any other provision of this code to the contrary, if a permit is issued in order to bring an unpermitted structure (as defined in Section R110.1.1 of this code) or other unlawful condition into compliance with any applicable law, or ordinance, such permit shall automatically expire and become null and void ninety (90) calendar days after the date on which the permit was issued. The Building Official may extend the validity of the permit for a period not exceeding ninety (90) calendar days beyond the initial ninety (90) day limit upon written request by the applicant filed with the Building Official prior to the expiration date of the original permit.*

l) Section R105.6 is amended to read as follows:

***R105.6 Suspension or revocation.*** *The Building Official is authorized to suspend or revoke a permit issued under the provisions of this code or other relevant laws, ordinances, rules, or regulations, wherever and whenever the permit is issued in error or on the basis of incorrect, inaccurate or incomplete information, or in violation of any ordinance or regulations or any of the provisions of this code.*

*The Building Official may also withhold inspections or approvals or suspend or revoke permit, where work is being performed in violation of approved plans, conditions of approval or permit, or applicable laws, and/or where work is being done not in accordance with the direction of the Building Official or this code.*

*The Building Official is authorized to suspend or revoke a permit if he/she, or a designee thereof, determines work is occurring in connection therewith between the hours of 7:00 p.m. and 7:00 a.m., Monday through Saturday and any time on Federal Holidays, which results in violations of the noise regulations located in Article 9, Chapter 6, Part 2, Division 6 of the Agoura Hills Municipal Code, and the*

*permittee has not received prior written permission from the city manager to create such noise at that time.*

*The building official is authorized to suspend or revoke a permit issued under the provisions of this code if dust is generated in excess of local, state or federal standards or conditions of project approval.*

m) Section R105.7 is amended to read as follows:

**R105.7 Placement of permit.** The building permit or copy shall be kept on the site of the work until completion of the project. *Required permits and approved plans shall be maintained in good condition and be posted or otherwise made available at job site such as to allow the building official to conveniently make the required review, inspection and entries related to the project.*

n) Section R105.8 is amended to read as follows:

**R105.8 Responsibility of permittee.** It shall be the duty of every person who performs work for the installation or repair of building, structure, electrical, gas, mechanical or plumbing systems, for which this code is applicable, to comply with this code. *Building permits shall be presumed by the City to incorporate all of the work that the applicant, the applicant's agent, employees and/or contractors shall carry out. Said proposed work shall be in accordance with the approved plans and with all requirements of this code and any other laws or regulations applicable thereto. No city approval shall relieve or exonerate any person from the responsibility of complying with the provisions of this code nor shall any vested rights be created for any work performed in violation of this code.*

o) Section R105.10 is added to read as follows:

**R105.10 Transferability.** *No permit issued pursuant to Article VIII of the Agoura Hills Municipal Code shall be transferable to any other person or apply to any location other than that stated in the permit, unless a justifiable cause is demonstrated to the satisfaction of the Building Official and approved in writing.*

p) Section R108.4.1 is added to read as follows:

**R108.4.1 Re-inspection Fee.** *A re-inspection fee may be assessed for each inspection or re-inspection when such portion of work for which inspection is called is not complete or when corrections previously called for are not made. This section is not to be interpreted as requiring re-inspection fees the first time a job is rejected for failure to comply with the requirements of this code, but as controlling the practice of calling for inspections before the job is ready for such inspection or re-inspection.*

*Re-inspection fees may be assessed when the inspection record permit card is not posted or otherwise available on the work site, the approved plans are not readily*



*available for the inspector, for failure to provide access on the date for which the inspection is requested, or for deviation from the plans requiring the approval of the building official. Where re-inspection fees have been assessed, no additional inspection of the work shall be performed until the required fees identified by the latest fees adopted by the City of Agoura Hills have been paid.*

- q) Section R108.5.1 is added to read as follows:

**R108.5.1 Refund Policy.** *The plan review fee for any project that has been reviewed will not be refunded since the review has been conducted already. When a project has been reviewed, approved and a permit has been issued, but no work or inspections has taken place and a refund is requested, the City will refund 80% of the original permit fee for which no work or inspection has been performed. There will be no refund given if the project has commenced and inspection taken place. The Building Official makes the final determination whether a refund is due for a specific project.*

- r) Section R108.6 is amended to read as follows:

**R108.6 Work commencing before permit issuance.** *Any person who commences any work for which a permit is required by this code before obtaining the necessary permits shall be subject to a special investigation by the Building Official before a permit may be issued for such work. An investigation fee, in addition to the permit fee, shall be collected whether or not a permit is then or subsequently issued. The investigation fee shall be equal to the amount of the permit fee required for such work by this code, or as identified in the latest fees adopted by the City Council of the City of Agoura Hills.*

- s) Section R108.7 is added to read as follows:

**R108.7 Plan review fees.** *When submittal documents are required by Section R107, a plan review fee shall be paid at the time of submitting the submittal documents for plan review. Said plan review fee shall be in accordance with the schedule as established by the applicable governing authority.*

*The plan review fees specified in this section are in addition to and separate fees from the permit fees specified in Section R108.2.*

*Where submittal documents are incomplete or changed so as to require additional plan review, or where the project involves deferred submittal items as defined in Section R106.3.3, an additional plan review fee may be charged at a rate established by the applicable governing authority.*

*When submittal documents are for a project involving production housing (track home), the plan review fee shall be based on full plan review for the first model home/unit and 20% of the fee for any reproduction of that model home/unit. If the model home/unit and the reproduction units are not the same size and configuration,*

*which would require a plan review, a full plan review fee or additional fee may apply, as determined by the Building Official.*

t) Section 109.1.4.3 is added to read as follows:

**R109.1.4.3 Roof sheathing and shear inspection.** *Prior to a complete framing inspection, a roof sheathing and shear inspection shall be made after roof sheathing and all structural shear panels or walls are in place and secured by nailing or other approved methods.*

u) Section 109.5 is added to read as follows:

**R109.5 Setback and height certification.** *When determined by the Building Official, a survey and certification may be required to confirm that the building or structure is placed on the site in accordance with the approved location and setback distances and to confirm that it does not exceed the approved building height shown on the approved plans.*

v) Section R110.1.1 is added to read as follows:

**R110.1.1 Unpermitted Structures.** *No person shall own, use, occupy, or maintain an unpermitted structure. For purposes of this subsection, "unpermitted structure" shall be defined as any building or structure, or portion thereof, that was erected, constructed, enlarged, altered, repaired, moved, improved, removed, connected, converted, demolished, or equipped with regulated devices, fixtures or installations, at any point in time by any person, without the required permit(s) having first been obtained from the Building Official, or with a valid permit as issued by the Building Official which subsequently expired and became null and void. An unpermitted structure also includes one for which a building permit has been suspended or revoked.*

w) Section R110.3 is amended to read as follows:

**R110.3 Certificate issued.** *After the building official or his/her designee inspects the building or structure and finds no violation of the provisions of this code or other laws that are enforced by the city, the building official shall issue a certificate of occupancy that contains the following:*

1. The *building* permit number.
2. The address of the structure.
3. The name and address of the owner or the owner's authorized agent.
4. A description of that portion of the structure for which the certificate is issued.
5. A statement that the described portion of the structure has been inspected for compliance with the requirements of this code *for the occupancy and*

*division of occupancy and the use for which the proposed occupancy is classified.*

6. The name of the building official.
7. The edition of the code under which the permit was issued.
8. When an automatic sprinkler system is provided, whether the sprinkler system is required.
9. Any special stipulations and conditions of the building permit.
10. Assessor's Parcel Number.
11. Zoning designation.
12. The date of certificate issuance.

x) Section R110.4 is amended to read as follows:

**R110.4 Temporary Certificate of Occupancy (TCO)** *The Building Official may, in writing, authorize temporary occupancy of any building or structure, or portion thereof, that lacks a permanent certificate of occupancy for any reason, provided patent conditions in open and accessible portions of the building or structure do not reveal a substantial hazard to an occupant or occupants.*

*Applications for a temporary certificate of occupancy shall be on a city-approved form. Such applications shall be accompanied by a fee to process the application and for the inspection of the building or structure to determine its suitability for a temporary certificate of occupancy. Such fees shall be established by the City Council by resolution.*

*A temporary certificate of occupancy is valid for a period of time to be specified by the Building Official in the certificate. The city attorney may require applicants for a temporary certificate of occupancy to execute an indemnification, as approved by the City Attorney, in favor of the city and its employees as a prerequisite to receiving a temporary certificate of occupancy.*

*The Building Official may extend the period of a temporary certificate of occupancy in writing, as well as impose conditions thereto. Property owners shall acknowledge and agree to said conditions in writing. The breach of any condition thereof shall render a temporary certificate of occupancy null and void without further action by the city. In such event, the owners shall cause all use and occupancy of the building or structure to be terminated by a date required by the Building Official. Use or occupancy of a building or structure, or allowing the use or occupancy of a building or structure, with an expired a temporary certificate of occupancy is a violation of this code and unlawful. Failing to cause the termination of all uses and occupancy in a structure after a termination date is a violation of this code and unlawful. The boards established by Section 1.8.8 do not have jurisdiction to consider, decide or rule decisions pertaining to the issuance, expiration, or nullification of a temporary certificate of occupancy, or with regard to any other matter relating thereto.*

*The Building Official is authorized to adopt regulations or procedures, such as requiring a security deposit or bond, for implementation of this section.*

y) Section R110.5 is amended to read as follows:

**R110.5 Revocation.** *The Building Official may, in writing, suspend or revoke a certificate of occupancy whenever the Building Official determines that the certificate was issued in error, or on the basis of incorrect information supplied, or when it is determined that the building, structure or premises, or portion thereof, is in violation of any provision of this code, or other relevant laws, ordinances, rules and/or regulations. Use or occupancy of a building or structure, or allowing the use or occupancy of a building or structure, with a suspended or revoked certificate of occupancy is a violation of this code and unlawful. The boards established by Section 1.8.8 do not have jurisdiction to consider, decide or rule pertaining to the issuance, suspension or revocation of a certificate of occupancy, or with regard to any other matter relating thereto.*

z) Section R111.3 is amended, and subsections R111.3.1, R111.3.2, and R111.3.3 are added, to read as follows:

**R111.3 Authority to Disconnect Service Utilities.** *The powers granted the Building Official pursuant to this subsection extend to all buildings, structures or systems (including electrical, plumbing and mechanical) that are regulated by this code and its references. This subsection supersedes all similar provisions in other codes that are part of Article VIII of the Agoura Hills Municipal Code.*

**R111.3.1 Authority to Disconnect Electric Utility.** *The Building Official is hereby empowered to disconnect or to require in writing the discontinuance of electric utility service to buildings, structures or premises, or portions thereof, or to wiring, devices or materials where such buildings, structures or premises, or portions thereof, are determined to be a hazard to life, health and/or property, or where they lack permits and required inspection approvals.*

*The Building Official is hereby empowered to disconnect or to require in writing the discontinuance of electric utility service as a means of preventing, restraining, correcting or abating any violation of this code, or other relevant laws, ordinances, rules or regulations.*

*The electrical service shall remain disconnected or electrical utility service shall remain discontinued until the code violation has been abated to the satisfaction of the Building Official, or until the installation of such wiring, devices or materials have been made safe as directed by the Building Official; or until a permit has been issued and the work has been inspected and approved by the Building Official.*

**R111.3.2 Authority to Disconnect Gas Utility.** *The Building Official is hereby empowered to disconnect or to require in writing the discontinuance of gas utility service to buildings, structures or premises, or portions thereof, or to appliances, devices or materials where such buildings, structures or premises, or portions thereof, are determined to be a hazard to life, health and/or property, or where they lack permits and required inspection approvals.*

*The Building Official is hereby empowered to disconnect or to require in writing the discontinuance of gas utility service as a means of preventing, restraining, correcting or abating any violation of this code, or other relevant laws, ordinances, rules or regulations.*

*The gas service shall remain disconnected or gas utility service shall remain discontinued until the code violation has been abated to the satisfaction of the Building Official, or until the installation of such appliances, devices or materials have been made safe as directed by the Building Official; or until a permit has been issued and the work has been inspected and approved by the Building Official.*

**R111.3.3 Authority to Disconnect Water Utility.** *The Building Official is hereby empowered to disconnect or to require the property owner to disconnect the water utility service to buildings, structures or premises, or portions thereof, or to fixtures, devices or materials where such buildings, structures or premises, or portions thereof, are determined to be a hazard to life, health, property or to the environment, or where they lack permits and required inspection approvals.*

*The Building Official is hereby empowered to disconnect or to require the property owner to disconnect the water utility service as a means of preventing, restraining, correcting or abating any violation of this code, or other relevant laws, ordinances, rules or regulations.*

*The water service shall remain disconnected or water utility service shall remain discontinued until the code violation has been abated to the satisfaction of the Building Official, or until the installation of such appliances, devices or materials have been made safe as directed by the Building Official; or until a permit has been issued and the work has been inspected and approved by the Building Official.*

aa) Section R112 is deleted in its entirety.

bb) Sections R113.1 is amended to read as follows:

**R113.1 Unlawful Acts.** *It is unlawful for any property owner and/or other responsible person to erect, construct, alter, extend, repair, move, remove, demolish, or occupy*

*any building or structure, as well as any regulated equipment, system or installation, or cause same to be done, in conflict with this code. It is unlawful for any for any property owner and/or other responsible person to conduct or maintain, whether due to action or inaction, any building or structure, as well as any regulated equipment, system or installation in violation of this code. It is unlawful for any property owner and/or other responsible person to conduct or maintain grading on land that occurred without a permit.*

cc) Section R113.4 is amended to read as follows:

**R113.4 Violation Penalties.** *Any person who violates, or who maintains a violation of this Code or who fails to comply with any of the requirements thereof or who erects, constructs, alters or repairs a building or structure in violation of the approved construction documents or who fails to comply with a directive or order of the Building Official, or of a permit or certificate issued under the provisions of this code, shall be subject to penalties as prescribed by law as follows:*

*(a) Any person, firm, partnership, association, corporation or joint venture violating any of the provisions of the California Building Standards Code or other code(s) adopted in Article VIII of the Agoura Municipal Code shall be guilty of a misdemeanor. Any person violating a stop work order issued pursuant to Section R114 of this chapter shall be guilty of a misdemeanor. Any person who continues to occupy or any person who enters a structure which has been posted "unsafe" by the building official pursuant to Section R113.5 of this chapter shall be guilty of a misdemeanor.*

*(b) Each day that person, firm, association, corporation or joint venture violates any of the provisions of the California Building Standards Code or other code(s) adopted in Article VIII of the Agoura Municipal Code is a separate offense and shall be punishable thereof as provided in the Agoura Hills Municipal Code.*

dd) Section R113.5 is added to read as follows:

**R113.5 Unsafe Conditions.** *Any building, structure or equipment that has any or all of the conditions hereinafter described shall constitute an unsafe or dangerous building or structure:*

*(a) Structural inadequacies, damage, deficiencies, defects or deterioration, as well as nearby hazardous embankments or excavations, that could cause a building or structure to partially or completely collapse or fail.*

*(b) Electrical, plumbing or mechanical work or installations, which because of a defect in materials or installation, or due to some other faulty operating or other condition, pose a risk of explosion or fire.*

*(c) Unsanitary or unhealthful conditions that are present in a building or structure.*

*(d) All forms of construction, as well as electrical, plumbing or mechanical work, systems, fixtures, appliances or other installations for which all required permits and inspection approvals have not been obtained from the Building Official.*

*(e) Occupancy or use for which a building or structure was not designed or intended, or that results in a change in the occupancy classification thereof.*

*(f) Inadequate egress from a building or structure.*

*(g) A vacant building or structure that is not secured against unauthorized entry.*

*(h) Any condition that violates any regulation in Article VIII of the Agoura Hills Municipal Code.*

*Any or all of the foregoing conditions endanger the health, safety or welfare of occupants, persons who may enter the premises, or the public.*

ee)Section R113.6 is added to read as follows:

***R113.6 Orders to Vacate.*** *Notwithstanding any other provision of this code, if the building official or a designee thereof, determines a condition is present in a building or structure or on premises that constitutes an immediate danger or hazard to the health, safety or welfare of occupants or to the public, the Building Official may order persons to vacate buildings, structures, premises, or portions thereof. Such orders may include orders to not re-enter, as well authorize limited entry subject to written conditions. Conditions may include, but not be limited to, requiring buildings, structures and premises to be secured from entry or access by means that are acceptable to the Building Official. Orders shall advise persons of their appeal rights as discussed in this subsection.*

*Orders may be personally served on an occupant, or served by first class mail and posted on the premises containing the immediate danger or hazard. If an owner does not occupy said premises, a copy of the order shall be also sent by first class mail to the owner as identified by Los Angeles County Assessor records. For owner-occupied properties, the issuance date of an order is the date of its personal service. For non-owner occupied properties, the issuance date of an order is the date an order to the owner and any occupant(s), or a copy thereof, are deposited in a U.S. Postal Service mail container and posted on the premises. Failure of any person to receive an order shall not affect its validity, or the appeal period. When identifying a mailing address for an owner, the Building Official shall consider such information as shown in Los Angeles County Assessor records.*

*Orders issued pursuant to this subsection, and any conditions thereof, are appealable by a property owner or occupant on a City-approved form that must be received by the City Clerk's Office within ten days of an order's issuance. Appellants shall state all*

*grounds for their appeal in said form. Failure to tender an appeal in a timely manner constitutes a waiver of the right to appeal, in which case an order is final.*

*If a timely appeal is made, the Building & Safety Department shall provide ten days advance written notice to the appealing party or parties of the date, time and place of the hearing. A timely appeal does not stay an order, or any conditions thereof. Failure of any person to receive a notice of hearing shall not affect its validity.*

*Timely appeals shall be heard by the housing or local appeals board, as applicable. Appeal hearings are informal and rules of evidence do not apply. Failure of an appellant or appellants to appear at a hearing constitutes a waiver of the right to appeal, in which case the order is final. The housing or local appeals board, as applicable shall, within ten days following the hearing, issue a written decision upholding, modifying, or reversing the order or conditions thereof, notice of which shall be sent to the appellant(s) by first class mail. Such decisions are not appealable. The notice of decision shall contain the following statement: "The [Housing Appeals Board/Local Appeals Board] decision is final, and judicial review of this decision is subject to the provisions and time limits set forth in Cal. Code of Civil Procedure §§ 1094.5 and 1094.6."*

*Orders may be accompanied by, or combined with, Stop Work Order or Notices of Violations (which are not appealable). Orders shall be rescinded in writing when the Building Official determines that the immediate danger or hazard has been fully corrected or abated with all permits, approvals and inspections as required by the Agoura Hills Municipal Code.*

ff) Section R113.7 is added to read as follows:

**Section R113.7 Violations.** *It is unlawful and a public nuisance for any person to maintain an unsafe or dangerous building or structure. Each and every day that a building or structure is maintained in an unsafe or dangerous condition is a new violation of this code. It is a violation of this code and unlawful for any person to fail to comply with an order to vacate, as well as all conditions thereof. Each such violation shall be a misdemeanor."*

gg) Section R114.1 is amended to read as follows:

**R114.1 Authority.** *Whenever the building official finds any work regulated by this code being performed in a manner either contrary to the provisions of this code or without permit, or dangerous, or unsafe, the Building Official is authorized to issue a stop work order.*

hh) Section R300.3 is added to read as follows:



**R300.3 Grading.** *The grading associated with the design and construction of new buildings, additions, and alterations to existing buildings shall comply with Appendix J of the California Building Code as adopted and amended by the City of Agoura Hills.*

ii) Section R301.1.3.2 is amended to read as follows:

**R301.1.3.2 Wood-frame structures.** *The building official shall require construction documents to be approved and stamped by a California licensed architect or engineer for all dwellings of wood-frame construction more than two stories and basement in height located in Seismic Design Category A, B or C. Notwithstanding other sections of law; the law establishing these provisions is found in Business and Professions Code Sections 5537 and 6737.1.*

*The building official shall require construction documents to be approved and stamped by a California licensed architect or engineer for all dwellings of woodframe construction more than one story in height or with a basement located in Seismic Design Category D<sub>0</sub>, D<sub>1</sub>, or D<sub>2</sub>.*

jj) Section R301.1.5 is added to read as follows:

**R301.1.5 Seismic design provisions for buildings constructed on or into slopes steeper than one unit vertical in three units horizontal (33.3 percent slope).** *The design and construction of new buildings and additions to existing buildings when constructed on or into slopes steeper than one unit vertical in three units horizontal (33.3 percent slope) shall comply with Section 1613.5 of the California Building Code, as incorporate in the Agoura Hills Municipal Code.*

kk) Section R301.2.2.11 is added to read as follows:

**R301.2.2.11 Anchorage of Mechanical, Electrical, or Plumbing Components and Equipment.** *Mechanical, electrical, or plumbing components and equipment shall be anchored to the structure. Anchorage of the components and equipment shall be designed to resist loads in accordance with the California Residential Code and ASCE 7, except where the component is positively attached to the structure and flexible connections are provided between the component and associated ductwork, piping, and conduit; and either*

- 1. The component weighs 400 lbs. (1,780 N) or less and has a center of mass located 4 ft. (1.22 m) or less above the supporting structure; or*
- 2. The component weighs 20 lbs. (89N) or less or, in the case of a distributed system, 5 lb/ft. (73 N/m) or less.*

ll) Section R337.1.1 is amended to read as follows:

**R337.1.1 Scope.** *Section R337 and all subsections apply to building materials, systems and or assemblies used in the exterior design and construction of new*

buildings, *and to additions, alterations, or repairs made to existing buildings, erected, constructed, located, or moved within the City of Agoura Hills or a Wildland-Urban Interface (WUI) Fire Area as defined in Section R337.2.*

mm) Section R337.1.3 is amended to read as follows:

**R337.1.3 Application.** *New buildings, and any additions, alterations, or repairs made buildings located in or moved within the City of Agoura Hills, or in any Fire Hazard Severity Zone, or any Wildland-Urban Interface (WUI) Fire Area designated by the enforcing agency constructed after the application date shall comply with the provisions of this Section. This shall include all new buildings, and any additions, alterations, or repairs made to existing buildings, with residential, commercial, educational, institutional or similar occupancy type use, which shall be referred to in this chapter as “applicable building” (see definition in Section R337.2), as well as new buildings and structures, and any additions, alterations, or repairs made to existing buildings accessory to those applicable buildings (see Exceptions 1 and 4).*

**Exceptions:**

1. Group U occupancy accessory buildings of any size located at least 50 feet from an applicable building on the same lot.
2. Group U occupancy agricultural buildings, as defined in Section 202 of this code of any size located at least 50 feet from an applicable building.
3. Group C occupancy special buildings conforming to the limitations specified in Section 450.4.1.
4. Accessory buildings and miscellaneous structures, *including additions, alterations, or repairs*, as specified in Section 710A shall comply only with the requirements of that Section.
5. *Reserved.*

nn) Section R337.1.3.1 is amended to read as follows:

**R337.1.3.1 Application date and where required.** *New buildings for which an application for a building permit is submitted on or after July 1, 2008, and any additions, alterations, or repairs made to existing buildings for which an application for a building permit is submitted on or after January 1, 2023, located in the City of Agoura Hills, or in any Fire Hazard Severity Zone, or in any Wildland–Urban Interface Fire Area shall comply with all sections of this Chapter.*

oo) Section R337.3.5.2.2 is amended to read as follows:

**R337.3.5.2.2. Fire-retardant-treated wood shingles and shakes.** Fire-retardant-treated wood shingles and shakes shall *not be approved for use in the City of Agoura Hills.*

pp) Section R337.5.2 is amended to read as follows:

**R337.5.2 Roof coverings.** Roof coverings shall be Class A as specified in Section R902.1. Where the roofing profile has an airspace under the roof covering, installed over a combustible deck, a 72 lb. (32.7 kg) cap sheet complying with ASTM D3909 Standard Specification for "Asphalt Rolled Roofing (Glass Felt) Surfaced with Mineral Granules," shall be installed over the roof deck. Bird stops shall be used at the eaves when the profile fits, to prevent debris at the eave. Hip and ridge caps shall be mudded in to prevent intrusion of fire or embers.

**Exception:**

Cap sheet is not required when no less than 1" of mineral wool board or other noncombustible material is located between the roofing material and wood framing or deck.

Alternately, a Class A fire rated roof underlayment, tested in accordance with ASTM E108, shall be permitted to be used. If the sheathing consists of exterior fire-retardant-treated wood, the underlayment shall not be required to comply with a Class A classification. Bird stops shall be used at the eaves when the profile fits, to prevent debris at the eave. Hip and ridge caps shall be mudded in to prevent intrusion of fire or embers. *Wood shingles and wood shakes are prohibited in the City of Agoura Hills or any Fire Hazard Severity Zones regardless of classification.*

qq) Section R401.1 is amended to read as follows:

**R401.1 Application.** The provisions of this chapter shall control the design and construction of the foundation and foundation spaces for buildings. In addition to the provisions of this chapter, the design and construction of foundations in flood hazard areas as established by Table R301.2 shall meet the provisions of Section R322. Wood foundations shall be designed and installed in accordance with AWC PWF.

**Exception:** The provisions of this chapter shall be permitted to be used for wood foundations only in the following situations:

1. In buildings that have no more than two floors and a roof.
2. When interior basement and foundation walls are constructed at intervals not exceeding 50 feet.

Wood foundations in Seismic Design Category D<sub>0</sub>, D<sub>1</sub>, or D<sub>2</sub> shall *not be permitted.*

**Exception:** *In non-occupied, single-story, detached storage sheds and similar uses other than carport or garage, provided the gross floor area does not exceed*

*200 square feet, the plate height does not exceed 12 feet in height above the grade plane at any point, and the maximum roof projection does not exceed 24 inches.*

rr) Section R403.1.2 is amended to read as follows:

**R403.1.2 Continuous footing in Seismic Design Categories D<sub>0</sub>, D<sub>1</sub> or D<sub>2</sub>.** Exterior walls of buildings located in Seismic Design Categories D<sub>0</sub>, D<sub>1</sub>, or D<sub>2</sub> shall be supported by continuous solid or fully grouted masonry or concrete footings. *Required interior braced wall panels in buildings located in Seismic Design Categories D<sub>0</sub>, D<sub>1</sub>, and D<sub>2</sub> shall be supported on continuous foundations.*

ss) Section R403.1.3.6 is amended to read as follows:

**R403.1.3.6 Isolated concrete footings.** In detached one- and two-family dwellings located in *Seismic Design Category A, B, or C*, that are three stories or less in height, and constructed with stud bearing walls, isolated plain concrete footings supporting columns or pedestals are permitted.

tt) Section R403.1.5 is amended to read as follows:

**R403.1.5 Slope.** The top surface of footings shall be level. The bottom surface of footings shall not have a slope exceeding one unit vertical in 10 units horizontal (10-percent slope). Footings shall be stepped where it is necessary to change the elevation of the top surface of the footings or where the slope of the bottom surface of the footings will exceed one unit vertical in 10 units horizontal (10-percent slope).

*For structures assigned to Seismic Design Categories D<sub>0</sub>, D<sub>1</sub>, or D<sub>2</sub>, stepped footings shall be reinforced with four No. 4 rebar. Two bars shall be placed at the top and bottom of the footings as shown in Figure R403.1.5.2.*

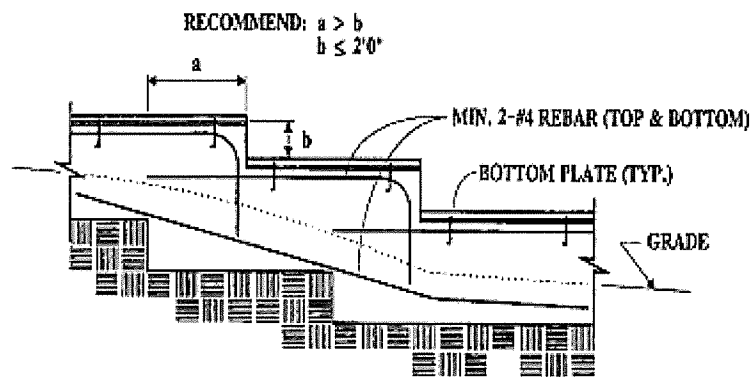

**STEPPED FOUNDATIONS**

uu) Section R404.2 is amended to read as follows:

**R404.2 Wood foundation walls.** Wood foundation walls shall be constructed in accordance with the provisions of Sections R404.2.1 through R404.2.6 and with the details shown in Figures R403.1(2) and R403.1(3). *Wood foundation walls shall not be used for structures located in Seismic Design Category D<sub>0</sub>, D<sub>1</sub> or D<sub>2</sub>.*

wv) Section AZ103.1 is amended to Appendix AZ to read as follows:

**AZ103.1 General.** Emergency sleeping cabins, emergency transportable housing units, membrane structures and tents constructed and/or assembled in accordance with this appendix, shall be occupied only during declaration of state of emergency, local emergency, or shelter crisis, *and authorized by the City Council.*

Buildings and structures constructed in accordance with the California Building Standards Code, used as emergency housing, shall be permitted to be permanently occupied.

### **8203. California Electrical Code Adopted with Local Amendments**

A. Adoption of California Electrical Code, 2022 Edition.

Pursuant to California Government Code §§ 50022.1 to 50022.8, the California Electrical Code, 2022 Edition, published as Title 24, Part 3, of the California Code of Regulations, is adopted by reference, subject to the amendments, additions and deletions set forth below.

One true copy of the California Electrical Code is on file in the office of the Building Official and is available for public inspection as required by law.

B. Amendments to the Code.

Section 89.100.0 is added to read as follows:

**89.100.0 Administration.** The 2022 California Building Code, as incorporated into the Agoura Hills Municipal Code, will govern the administration of the California Electrical Code.

### **8204. California Mechanical Code Adopted with Local Amendments**

A. Adoption of California Mechanical Code, 2022 Edition.

Pursuant to California Government Code § 50022.1 to 50022.8, the California Mechanical Code ("CMC"), 2022 Edition, published as Title 24, Part 4, of the California Code of Regulations, is adopted by reference, subject to the amendments, additions and deletions set forth below.

One true copy of the CMC, is on file in the office of the Building Official and is available for public inspection as required by law.”

B. Amendments to the Code.

a) Section 100.0 is added to read as follows:

**100.0 Administration** The 2022 California Building Code, as incorporated into the Agoura Hills Municipal Code, will govern the administration of the CMC.

**8205. California Plumbing Code Adopted with Local Amendments.**

A. Adoption of California Plumbing Code, 2022 Edition.

Pursuant to California Government Code § 50022.1 to 50022.8, the California Plumbing Code, 2022 Edition, published as Title 24, Part 5, of the California Code of Regulations, (“CPC”) is adopted by reference, subject to the amendments, additions and deletions set forth below.

One true copy of the CPC is on file in the office of the Building Official and is available for public inspection as required by law.

B. Amendments to the Code.

a) Section 100.0 is added to read as follows:

**100.0 Administration.** The 2022 California Building Code, as incorporated into the Agoura Hills Municipal Code, will govern the administration of the CPC.

b) Section 1208.13.1 (Seismic Gas Shutoff Valves) is added to read as follows:

**1208.13.1 Seismic Gas Shutoff Valves**

**1208.13.1.1 Scope.** *A seismic gas shutoff valve shall be installed in compliance with the requirements of this section on each gas fuel line in the following:*

**1208.13.1.1.1** *Any building or structure, with gas fuel line, for which a building permit was first issued on or after January 1, 2023.*

**1208.13.1.1.2.** *Any building or structure which is altered or expanded under a building permit first issued on or after January 1, 2023, when such alteration or addition is valued at more than \$10,000.*

**1208.13.1.1.3.** *Any building or structure sold on or after January 1, 2023. However, when an individual condominium unit is sold in a building that has multiple gas lines, then the requirements of this section shall apply only to the line or lines serving the condominium unit that has been sold.*

**1208.13.1.2. Maintenance.** *Where the installation of a seismic gas shutoff valve is required by this section in any building or structure, that seismic gas shutoff valve shall be maintained for the life of that building or structure or shall be replaced with a valve complying with the requirements of this section.*

**1208.13.1.3 General Requirements.** *Where the installation of a seismic gas shutoff valve on a fuel line is required by this section, that valve must:*

**1208.13.1.3.1** *Be mounted rigidly to the exterior of the building or structure containing the fuel line unless the building official determines that the seismic gas shutoff valve has been tested and listed for an alternate method of installation.*

**1208.13.1.3.2** *Be installed downstream of the gas utility meter, except that a valve may be installed upstream of the gas utility meter at the discretion of the gas utility if the valve would otherwise meet the requirements of this section.*

**1208.13.1.3.3** *Be listed by an approved testing laboratory and certified by the Office of the State Architect.*

**1208.13.1.3.4** *Have a thirty-year warranty which warrants that the valve is free from defects and will continue to properly operate for thirty years from the date of operation.*

**1208.13.1.4 Critical Facilities.** *The requirements of this Section shall not apply to any building that is used by any public agency for the provision of emergency services, including fire, police, and similar public safety services.*

**1208.13.1.5 Definitions.** *For purposes of this section, certain terms shall be defined as follows:*

**1208.13.1.5.1** *Downstream of the Gas utility meter shall refer to all customer owned gas piping.*

**1208.13.1.5.2** *Seismic Gas Shutoff Valve shall mean a system consisting of a seismic sensing means and actuating means designed to automatically actuate a companion gas shutoff means installed in a gas piping system in order to shut off the gas downstream of the location of the gas shutoff means in the event of a severe seismic disturbance. The system may consist of separable components or may incorporate all functions in a single body. The terms "seismically activated gas shutoff valves" and "earthquake sensitive gas shutoff valves," are synonymous.*

**1208.13.1.5.3** *Upstream of the Gas Utility meter shall refer to all gas piping installed by the utility up to and including the meter and the utility's bypass toe at the connection to the customer owned piping.*

## **8206. California Energy Code Adopted**

Pursuant to California Government Code §§ 50022.1 to 50022.8, the California Energy Code, 2022 Edition, published as Title 24, Part 6, of the California Code of Regulations is adopted by reference.

One true copy of the California Energy Code, is on file in the office of the Building Official and is available for public inspection as required by law.

**8207. Reserved.**

**8208. California Historical Building Code Adopted with Local Amendments**

A. Adoption of California Historical Building Code, 2022 Edition

Pursuant to California Government Code §§ 50022.1 to 50022.8, the California Historical Building Code (“CHBC”), 2022 Edition, published as Title 24, Part 8, of the California Code of Regulations is adopted by reference, subject to the amendments, additions and deletions set forth below.

One true copy of the CHBC is on file in the office of the Building Official and is available for public inspection as required by law.

B. Amendments to the Code

a) Section 8-100.0 is added to read as follows:

**8-100.0 Administration.** The 2022 California Building Code, as incorporated into the Agoura Hills Municipal Code, will govern the administration of the CHBC.

**8209. Reserved.**

**8210. California Existing Building Code adopted with local Amendments**

A. Adoption of California Existing Building Code, 2022 Edition.

Pursuant to California Government Code § 50022.1 to 50022.8, the California Existing Building Code (“CEBC”), 2022 Edition, published as Title 24, Part 10, of the California Code of Regulations, is adopted by reference, subject to the amendments, additions and deletions set forth below. Appendix A (Guidelines for Seismic Retrofit of Existing Buildings) with Chapters A1, A2, A3, A4 is also adopted as Voluntary Earthquake Hazard Reduction Measures in Existing Buildings (Voluntary Seismic Retrofit).

One true copy of the CEBC, is on file in the office of the Building Official and is available for public inspection as required by law.”

B. Amendments to the Code.

a) Section 100.0 is added to read as follows:



**100.0 Administration.** The 2022 California Building Code, as incorporated into the Agoura Hills Municipal Code, will govern the administration of the CEBC.

**8211. California Green Building Standards Code Adopted with Local Amendments.**

A. Adoption of California Green Building Standards Code, 2022 Edition.

Pursuant to California Government Code §§ 50022.1 to 50022.8, the California Green Building Standards Code (“CGBSC”), 2022 Edition, published as Title 24, Part 11, of the California Code of Regulations is adopted by reference, subject to the amendments, additions and deletions set forth below.

One true copy of the CGBSC, is on file in the office of the Building Official and is available for public inspection as required by law.”

B. Amendments to the Code.

a) Section 100.0 is added to read as follows:

**100.0 Administration.** The 2022 California Building Code, as incorporated into the Agoura Hills Municipal Code, will govern the administration of the CGBSC.

b) Section 202 is amended by adding a definition for Bicycle Lockers to read as follows:

**202 Definitions. Bicycle Locker.** A permanently anchored facility or equipment used for locking the bicycles in place. This must be covered, but does not have to be enclosed.

**8212. California Referenced Standards Code adopted**

The 2022 Edition of the California Referenced Standards Code, published by the International Code Council, and all appendices, amendments, supplements and errata thereto, is hereby adopted by reference and shall be applicable to the City of Agoura Hills, and referred to as the “Referenced Standards Code of the City of Agoura Hills.”

One copy of the California Referenced Standards Code of the City of Agoura Hills shall be kept on file in the Building Official’s office for public inspection.

**8213. Reserved.**

**8214. Reserved.**

**8215. Reserved.**

**8216. Expedited Review of Small Residential Rooftop Solar Energy System Permits.**

## **A. DEFINITIONS**

“Small residential rooftop solar energy system” shall have the same meaning as provided in the Solar Rights Act, Government Code § 65850.5(j)(3), as the same may be amended from time to time.

## **B. SMALL RESIDENTIAL ROOFTOP SOLAR ENERGY SYSTEM STANDARD PLAN AND PERMIT APPLICATION CHECKLIST**

1. The City shall adopt standard plan(s) and checklist(s) of all requirements with which small residential rooftop solar energy systems shall comply to be eligible for expedited review. The small residential rooftop solar system standard plan(s) and checklist(s) shall substantially conform to recommendations for expedited permitting, including the checklists and standard plans contained in the most current version of the California Solar Permitting Guidebook adopted by the Governor’s Office of Planning and Research.

2. All documents required for the submission of a small residential rooftop solar energy system permit application, the standard plan(s), and checklist(s) shall be made available on the publicly accessible City Website.

3. Electronic submittal of the required permit application and documents by e-mail shall be available to all small residential rooftop solar energy system permit applicants. An applicant’s electronic signature shall be accepted on all forms, applications, and other documents in lieu of a wet signature.

## **C. PERMIT APPLICATION REVIEW**

1. An application that satisfies the information requirements in the checklist(s) and standard plan(s) shall be deemed complete.

2. If an application is deemed incomplete, a written correction notice detailing all deficiencies in the application and any additional information or documentation required to be eligible for expedited permit issuance shall be sent to the applicant for resubmission.

3. The Building Official or his or her designee shall issue a building permit for any complete application that meets the requirements of the approved checklist(s) and standard plan(s) as follows: within three [3] business days for any application, or as soon thereafter as may be practicable. Review of the application shall be limited to the Building Official’s or his or her designee’s review of whether the application meets local, state, and federal health and safety requirements.

4. Any condition imposed on an application shall be designed to mitigate the specific, adverse impact upon health and safety at the lowest possible cost.

## **D. INSPECTION REQUIREMENTS**

1. Inspection requests may be submitted by phone, e-mail, or in person.

2. Only one inspection shall be required and performed by the Building Official or his or her designee for small residential rooftop solar energy systems eligible for expedited review.

3. The inspection shall be done in a timely manner. The Building Official or his or her designee shall use their best efforts to schedule an inspection within one [1] business day of a request and provide a two [2] hour inspection window.

4. If a small residential rooftop solar energy system fails inspection, a subsequent inspection is authorized but need not conform to the requirements of this Section.

#### **E. FEES.**

Fees for permits and inspections associated with this Chapter may be established by resolution of the City Council.”

#### **F. VIOLATIONS. PENALTIES.**

In addition to any other applicable provision of this article VIII, any person, firm, partnership, association, corporation or joint venture violating any of the provisions of this chapter shall be guilty of a misdemeanor.

### **8217. Expedited Review of Electric Vehicle Charging Station Permits.**

#### **A. APPLICABILITY**

This section applies to applications for expedited building permits for electric vehicle charging stations consistent with California Government Code Section 65850.7.

#### **B. DEFINITIONS**

1. “Electric vehicle charging station” or “charging station” means any level of electric vehicle supply equipment station that is designed and built in compliance with Article 625 of the California Electrical Code, as it read on January 1, 2016, and delivers electricity from a source outside of an electric vehicle into a plug-in electric vehicle.

2. “Electronic submission” means a submission of an application utilizing email, the internet, and/or facsimile transmission.

3. “Specific, adverse impact” means a significant, quantifiable, direct, and unavoidable impact, based on objective, identified, and written public health or safety standards, policies, or conditions as they existed on the date an application was deemed complete.

#### **C. PROCESS**

1. The building official shall adopt a checklist of all application requirements for expedited building permits for electric vehicle charging stations. The checklist shall substantially conform to the most current version of the "Plug-In Electric Vehicle Infrastructure Permitting Checklist" found in the "Zero-Emission Vehicles in California: Community Readiness Guidebook" published by the Governor's Office of Planning and Research. The checklist, application form, and any other documents required by the building official shall be published on the City's website.

2. Anyone seeking to install an electric vehicle charging station at any site within the City shall apply to the building official for an expedited nondiscretionary building permit.

3. An application for an expedited building permit for an electric vehicle charging station, and all associated documentation, may be submitted to the building official in person, by mail, or by electronic submission. Electronic signatures may be used in lieu of wet signatures.

4. An application that, in the opinion of the building official, satisfies the information requirements of the checklist adopted by the City shall be deemed complete.

5. If an application for an expedited building permit is deemed incomplete, the building official shall provide a written correction notice of the deficiencies and the additional information required to complete the application.

6. If the building official determines that an application for an expedited building permit is complete, the building official shall process the application. If the building official determines that the proposed charging station meets all health and safety requirements of state and federal law, and would not have a specific, adverse impact upon the public health or safety, the application shall be approved and a building permit shall be issued.

7. If the building official finds, based on substantial evidence, that a proposed charging station could have a specific, adverse impact upon the public health or safety, the City may require the applicant to apply for an electric vehicle charging station use permit in order to install the proposed charging station.

8. An application for an electric vehicle charging station use permit shall be reviewed by the building official. The building official shall not deny such an application without making written findings, based upon substantial evidence in the record, that the proposed charging station would have a specific, adverse impact upon the public health or safety which could not feasibly be satisfactorily mitigated or avoided. The written findings required for the rejection of an electric vehicle charging station use permit application shall include the building official's basis for rejecting any potentially feasible alternatives that could mitigate or prevent the alleged adverse impact. Pursuant to Government Code Section 65850.7, the building official's review shall be limited to health and safety issues. Aesthetic concerns, or other items not related to public health or safety may not be considered.

9. A decision of the building official made pursuant to paragraphs 6-8 of this subsection may be appealed to the Planning Commission. The Planning Commission's review shall also be limited to health and safety issues.

10. Any condition imposed on an application for an expedited building permit or electric vehicle charging station use permit shall be designed to mitigate the specific, adverse impact upon health and safety at the lowest possible cost.

**D. FEES.**

Fees for permits and inspections associated with this Chapter may be established by resolution of the City Council.”

**E. VIOLATIONS PENALTIES.**

In addition to any other applicable provision of this article VIII, any person, firm, partnership, association, corporation or joint venture violating any of the provisions of this chapter shall be guilty of a misdemeanor.

**8218. Reserved.**

**8219. Reserved.”**

**SECTION 4:** Section 8300 of Chapter 3 (Property Maintenance and Unsafe Structures) of Article VIII (Building Regulations) of the Agoura Hills Municipal Code is hereby amended as follows:

**“8300. INTERNATIONAL PROPERTY MAINTENANCE CODE ADOPTED WITH LOCAL AMENDMENTS.**

A. Adoption of International Property Maintenance Code, 2021 Edition. Pursuant to California Government Code § 50022.1 to 50022.8, the International Property Maintenance Code (“IPMC”), 2021 Edition, promulgated and published by the International Code Council, is adopted by reference, subject to the amendments, additions and deletions set forth below.

One true copy of the IPMC, is on file in the office of the Building Official and is available for public inspection as required by law.

B. Amendments to the Code.

a) Section 101.1 of the IPMC is amended to read as follows:

**101.1 Title.** These regulations shall be known as the International Property Maintenance Code of *Agoura Hills*, herein referred to as “this code.”

b) Section 103.1 of the IPMC is amended to read as follows:

**103.1 Agency.** *The City of Agoura Hills Community Development Department is the code compliance agency* and the official in charge thereof shall be known as

the code official. The function of the agency shall be the implementation, administration, and enforcement of the provisions of this code.

c) Section 103.5 of the IPMC is amended to read as follows:

**103.5 Fees.** *The fees for activities and services performed by the code official under this code shall be in accordance with the schedule as established by the applicable governing authority.*

d) Section 106 of the IPMC is deleted and replaced to read as follows:

**106. Violations.** *Refer to Chapter 6, Article V of the City of Agoura Hills Municipal Code.*

e) Section 107 of the IPMC is deleted and replaced to read as follows:

**107. Notices and Orders.** *Refer to Chapter 6, Article V of the City of Agoura Hills Municipal Code.*

f) Sections 108.1 of the IPMC is amended as follows:

**108.1 Membership of board** is deleted in its entirety. *The 2022 California Building Code, as incorporated into the Agoura Hills Municipal Code, will govern the administration of the IPMC.*

g) Sections 111 of the IPMC is deleted and replaced to read as follows:

**111. Means of Appeals.** *The Planning Commission of the City of Agoura Hills shall act as the Board of Appeals as it relates to this Chapter of the Municipal Code. Any person directly affected by a decision of the City's code officials or a notice or order issued under this Maintenance code shall have the right to appeal the decision by having a Planning Commission hearing. This hearing will be set by the Director of Community Developments.*

h) Section 113 of the IMPC is added to read as follows:

**SECTION 113. COST RECOVERY**

**113.1 Cost of City service.** *The cost to the City of any demolition or repair carried out under this code, including the entire cost of the services rendered by the City, shall be a special assessment against the property upon which the structure is located.*

**113.2 Account of costs and receipts and notice of assessment.** *The code official will notify in writing all parties concerned of the amount of such assessment resulting from such work. Within five days of the receipt of such notice, any*

*concerned party may file a written request with the code official requesting a hearing on the correctness or reasonableness, or both, of such assessment. The board of appeals thereupon shall set the matter for hearing, give such concerned party notice thereof as provided in Section 107.3 of this code, and hold such hearing and determine the reasonableness or correctness of the assessment. The board of appeals shall notify in writing such party concerned of its decision. If the total assessment determined as provided for in this section is not paid in full within ten days after receipt of such notice from the board of appeals, the code official shall record in the office of the department or registrar-recorder a statement of the total balance still due and a legal description of the property. From the date of such recording, such balance due shall be a special assessment against the parcel.*

**113.3 Collection with ordinary taxes.** *The special assessment set forth shall be collected at the same time and in the same manner as ordinary county taxes are collected, and shall be subject to the same penalties, interest, and procedures for foreclosure and sale in case of delinquency, as is provided for ordinary County taxes. All laws applicable to the levy, collection and enforcement of County taxes shall be applicable to such assessment.*

**SECTION 5.** If any provision of this Ordinance is for any reason held to be invalid by a court of competent jurisdiction, the City Council hereby declares that it would have passed each and every remaining provision irrespective of such holding in order to accomplish the intent of this ordinance.

**SECTION 6.** The Building Official is hereby authorized and directed to transmit a copy of this ordinance to the California Building Standards Commission as required by California Health and Safety Code Section 17958.7.

**SECTION 7.** The City Clerk shall certify to the passage of this ordinance and shall cause a summary of same to be published at least once in the local newspaper of general circulation, circulated within the City of Agoura Hills. A copy of the full text of this ordinance shall be on file in the Office of the City Clerk on and after the date following introduction and passage and shall be available to any member of the public.

This ordinance shall go into effect on the latter of the 31<sup>st</sup> day after its adoption or January 1, 2023.

**PASSED, APPROVED, AND ADOPTED,** this \_\_\_\_ day of \_\_\_\_\_, 2022.

AYES:        ( )  
NOES:        ( )  
ABSENT:     ( )  
ABSTAIN:    ( )

---

Deborah Klein Lopez, Mayor

ATTEST:

---

Kimberly M. Rodrigues, MMC, City Clerk

APPROVED AS TO FORM:

---

Candice K. Lee, City Attorney



**RESOLUTION NO. 22-2024**

**A RESOLUTION OF THE CITY COUNCIL OF THE CITY OF AGOURA HILLS, CALIFORNIA, MAKING FINDINGS THAT AMENDMENTS TO THE 2022 EDITIONS OF THE CALIFORNIA BUILDING, RESIDENTIAL, PLUMBING, FIRE, EXISTING BUILDING, AND GREEN BUILDING STANDARDS CODES, AS ADOPTED BY ORDINANCE OF THE CITY OF AGOURA HILLS, ARE REASONABLY NECESSARY BECAUSE OF LOCAL CLIMATIC, GEOLOGICAL, OR TOPOGRAPHICAL CONDITIONS**

**WHEREAS**, it is the desire and intent of the City Council of the Agoura Hills to provide citizens with the greatest degree of structural, fire, and life safety in buildings in the most cost-effective manner by adopting that body of regulations referred to as the 2022 California Building Standards Code with amendments specific to the City of Agoura Hills; and

**WHEREAS**, the City Council has determined that the provisions of the 2022 California Building Standards Code shall be adopted as modified, changed, and amended, as provided for in the ordinance, based upon the specific findings, and that said Council takes said action in order to more fully preserve and protect the public health, safety, welfare, and property.

**WHEREAS**, the City Council proposed to make modifications to building standards in the 2022 California Building Code, 2022 California Residential Code, 2022 California Plumbing Code, 2022 California Existing Building Code, 2022 California Fire Code, and 2022 California Green Building Standards Code, which will be more restrictive than State Law; and,

**WHEREAS**, California Health and Safety Code Section 17958.5 requires the City Council make express findings before adopting such changes, and Section 17958.7 requires that such findings be filed with the California Building Standards Commission.

**NOW, THEREFORE, THE CITY COUNCIL OF THE CITY OF AGOURA HILLS DOES HEREBY RESOLVE AS FOLLOWS:**

1. Amendments to building standards in the 2022 editions of the California Building Code, California Residential Code, California Plumbing Code, California Existing Building Code, California Fire Code, and California Green Building Standards Code, proposed to be adopted in Ordinance No. 22-465 by the City Council, are reasonably necessary because of local climatic, geological and/or topographical conditions that create seismic hazards, landslides, erosion, and wildfire, as well as the negative impact of the amount of energy, air quality, greenhouse gas emission and construction waste in the area. A summary of the amendments, with specific references to the express findings, is provided in the table attached hereto as Exhibit A, and is incorporated by reference herein.

2. Based on local climatic, geological and/or topographical conditions, the City has incorporated amendments to the Codes comprising the 2022 California Building Standards Code, as set forth in detail in Ordinance No. 22-465.

3. The City Clerk of the City of Agoura Hills shall file a copy of Ordinance No. 22-465, as amended, together with a copy of this Resolution, with the California Building Standards Commission, and shall obtain an endorsed copy from said Department to be filed with the City of Agoura Hills.

**PASSED, APPROVED, AND ADOPTED**, this \_\_\_\_ day of \_\_\_\_\_, 2022.

- AYES:        ()
- NOES:        ()
- ABSENT:     ()
- ABSTAIN:    ()

\_\_\_\_\_  
Deborah Klein Lopez, Mayor

ATTEST:

\_\_\_\_\_  
Kimberly M. Rodrigues, MMC, City Clerk

APPROVED AS TO FORM:

\_\_\_\_\_  
Candice K. Lee, City Attorney

## EXHIBIT A EXPRESS FINDINGS

### 2022 CALIFORNIA BUILDING CODE AMENDMENTS

2022 LARUC P NO.	TITLE/DESCRIPTION	EXPRESS FINDINGS
	Amend Section 1.8.8.1	A
	Add Section 1.8.8.4 - Limitation of Authority	A
	Amend Section 101.1 - Title.	A
	Amend Section 101.4.1 - Gas	A
	Amend Section 101.4.5 - Fire Prevention	A
	Amend Section 103.3 - Deputies	A
	Amend Section 105.1 - Required	A
	Amend Section 105.2 - Permit Exemptions	A
	Amend Section 105.3.2 - Time limitation of application	A
	<b>Add Section 105.3.2.1 - Time limitation of application in connection with an unpermitted structure</b>	A
	Amend Section 105.5 - Expiration of permit	A
	<b>Amend Section 105.5.1 - Expiration</b>	A
	<b>Add Section 105.5.2 - Expiration of permit in connection with an unpermitted structure</b>	A
	Amend Section 105.6 - Suspension or revocation	A
	Amend Section 105.7 - Placement of permit	A
	<b>Add CBC Section 105.8 Responsibility of permittee</b>	A
	Add Section 105.9 of Transferability	A
	Amend Section 109.4 - Work commencing before permit issuance	A
	Add Section 109.5.1 - Re-inspection Fee	A
	Add Section 109.6.1 - Refund Policy	A
	Add Section 109.7 - Plan review fees	A
	Add Section 110.1.1 - Setback and height certification	A
	Add Section 110.3.4.2 - Roof sheathing and shear inspection.	A
	Delete Exception for Section 110.3.6 - Lath, Gypsum Board, and Gypsum Panel Product Inspection	A
	Add Section 111.1.1 to - Unpermitted Structures	A
	Amend Section 111.2 - Certificate issued	A
	Amend Section 111.3 - Temporary Certificate of Occupancy (TCO)	A
	Amend Section 111.4 -Revocation	A
	Amend Section 112.3 and add subsections 112.3.1, 112.3.2, and 112.3.3 to - Authority to Disconnect Service Utilities	A
	Delete Section 113 - Means of Appeals	A
	Amend Sections 114.1 - Unlawful Acts	A
	Amend Section 114.4 - Violation Penalties	A
	Amend Section 115.1 - Authority.	A
	Amend Section 116.1 - Conditions	A
	Add Section 116.3.1 - Orders to Vacate	A
	Delete Sections 116.4 and 116.5	A
	Add Section 116.6 to - Violations	A
	<b>Amend CBC Section 701A.1 - Scope</b>	C
	<b>Amend CBC Section 701A.3 - Application</b>	C
	<b>Amend CBC Section 701A.3.1- Application date and where required</b>	C
	Amend CBC Section 705A.2 - Roof coverings	C



	Amend CBC Section 903.2 - Where required	C
16-04	<b>Add CBC Section 1613.5 Seismic Design Provisions for Hillside Buildings</b>	B,C,D
18-01	<b>Amend CBC Section 1807.1.4 Permanent Wood Foundation System</b>	B,C
18-03	<b>Amend CBC Section 1807.2 Retaining Walls</b>	B,C,D
18-05	<b>Amend CBC Section 1809.3 Stepped Footings</b>	B,D
18-06	<b>Amend CBC Section 1809.7 and Table 1809.7 Prescriptive Footings for Light-Frame Construction</b>	B
18-07	<b>Amend CBC Section 1809.12 Timber Footings</b>	B,C
23-01	<b>Amend CBC Section 2304.10.2 Fastener Requirement</b>	B
23-03	<b>Amend CBC Section 2304.12.2.8 Wood Used in Retaining Walls and Cribs</b>	B,C
23-05	<b>Amend CBC Section 2306.2 Wood-Frame Diaphragms</b>	B
23-06	<b>Amend CBC Section 2306.3 Wood-Frame Shear Walls</b>	B
23-10	<b>Amend CBC Section 2308.6.8.1 Foundation Requirements</b>	B
	Amend CBC Section 3109.2 - Definitions	A
31-01	<b>Amend CBC Section 3115 – Inter-model Shipping Container</b>	F
	<b>Add CBC Section J101.3 Hazards</b>	E
	<b>Add CBC Section J101.4 Safety Precautions</b>	E
	<b>Add CBC Section J101.5 Protection of Utilities</b>	A,E
	<b>Add CBC Section J101.6 Protection of Adjacent Properties</b>	E
	<b>Add CBC Section J101.7 Stormwater control measures</b>	E
	<b>Add CBC Section J101.8 Conditions of approval</b>	A
	<b>Add CBC Section J101.9 Rules and regulations</b>	A
	<b>Amend CBC Section J103.2 Exemptions.</b>	A
	<b>Add CBC Section J103.3 Permit issuance</b>	A,E
	<b>Add CBC Section J103.4 Grading fees</b>	A
	<b>Add CBC Section J104.2.1 Grading Designation</b>	A
	<b>Add CBC Section J104.2.2 Regular grading requirements</b>	A
	<b>Add CBC Section J104.2.3 Engineered grading requirements</b>	A
	<b>Add CBC Section J105.3 Permittee.</b>	A
	<b>Add CBC Section J105.4 Required inspections.</b>	A,E
	<b>Add CBC Section J109.5 Disposal</b>	A,E
	<b>Add CBC Section J112 - National Pollutant Discharge Elimination System (NPDES) Compliance</b>	A,E
	<b>Adopting Appendix J - Grading</b>	A,E
	<b>Adopting Appendix P– Emergency Housing</b>	C
	<b>Amending Appendix P P103.1 – General</b>	A

**2022 CALIFORNIA PLUMBING CODE AMENDMENTS**

2022 LARUCP NO.	TITLE/DESCRIPTION	EXPRESS FINDINGS
	<b>Add CPC Section 1208.13.1 - Seismic Gas Shutoff Valves</b>	B

**2022 CALIFORNIA GREEN BUILDING STANDARDS CODE AMENDMENTS**

2022 LARUCP NO.	TITLE/DESCRIPTION	EXPRESS FINDINGS
	Amend CALGreen Section 202	A



## 2022 CALIFORNIA RESIDENTIAL CODE AMENDMENTS

2022 LARUCP NO.	TITLE/DESCRIPTION	EXPRESS FINDINGS
	Amend Section 1.8.8.1	A
	Add Section 1.8.8.4 - Limitation of Authority	A
	Amend Section R101.1 - Title.	A
	Amend Section R103.3 - Deputies	A
	Amend Section 105.1 - Required	A
	Amend Section R105.2 - Permit Exemptions	A
	<b>Amend Section R105.3.2 - Time limitation of application</b>	A
	<b>Add Section R105.3.2.1 - Time limitation of application in connection with an unpermitted structure</b>	A
	Amend Section R105.5 - Expiration of permit	A
	Amend Section R105.5.1 Expiration	A
	<b>Add Section 105.5.2 Expiration of permit in connection with an unpermitted structure</b>	A
	Amend Section R105.6 - Suspension or revocation	A
	Amend Section R105.7 - Placement of permit	A
	<b>Amend Section R105.8 -Responsibility</b>	A
	Add Section R105.10 - Transferability	A
	Add Section R108.4.1 - Re-inspection Fee	A
	Add Section R108.5.1 - Refund Policy	A
	Amend Section R108.6 - Work commencing before permit issuance	A
	Add Section R108.7 - Plan review fees	A
	Add Section R109.1.4.3 -Roof sheathing and shear inspection.	A
	Add Section R109.5 - Setback and height certification	A
	Add Section R110.1.1 - Unpermitted Structures	A
	Amend Section R110.3 - Certificate issued	A
	Amend Section R110.4 - Temporary Certificate of Occupancy (TCO)	A
	Amend Section R110.5 -Revocation	A
	Amend Section R111.3 and add subsections R111.3.1, R111.3.2, and R111.3.3 - Authority to Disconnect Service Utilities	A
	Delete Section R112 - Means of Appeals	A
	Amend Sections R113.1 - Unlawful Acts	A
	Amend Section R113.4 - Violation Penalties	A
	Add Section R113.5 – Unsafe Conditions	A
	Add Section R113.6 - Orders to Vacate	A
	Add Section R113.7 - Violations	A
	Amend Section R114.1 - Authority.	A
	<b>Add R300.3 - Grading</b>	D
R3-01	<b>Amend CRC Section R301.1.3.2 Woodframe Structures</b>	B,C
R3-02	<b>Add CRC Section R301.1.5 Seismic Design Provisions for Buildings on Slopes Steeper than 33%</b>	B,C
R3-04	<b>Add R301.2.2.11 -Anchorage of Mechanical, Electrical, or Plumbing Components and Equipment</b>	B
	<b>Amend R337.1.1 -Scope</b>	C
	<b>Amend R337.1.3 -Application.</b>	C
	<b>Amend R337.1.3.1 -Application date and where required.</b>	C
	<b>Amend R337.3.5.2.2. Fire-retardant-treated wood shingles and shakes.</b>	C
	<b>Amend R337.5.2 - Roof coverings.</b>	C
R4-01	<b>Amend CRC Section R401.1 Application</b>	B,C



R4-02	<b><i>Amend CRC Section R403.1.2 –Continuous footings</i></b>	B
R4-02	<b><i>Amend CRC Sections R403.1.3.6 – Isolated concrete footings</i></b>	B
R4-02	<b><i>Amend CRC Sections R403.1.5 Slope</i></b>	B
R4-03	<b><i>Amend CRC Section R404.2 - Wood Foundation Walls</i></b>	B,C
R5-01	<b><i>Amend CRC Section R501.1- Application</i></b>	B
	<b><i>Adopt Appendix AQ – Tiny Houses</i></b>	B,C
	<b><i>Adopt Appendix AX - Swimming Pool Safety Act</i></b>	A,C
	<b><i>Adopt - Appendix AZ Emergency Housing</i></b>	B,C
	<b><i>Amending Appendix AZ AZ103.1 – General</i></b>	A

**2022 CALIFORNIA FIRE CODE AMENDMENTS**

<b>2022 LARUCP NO.</b>	<b>TITLE/DESCRIPTION</b>	<b>EXPRESS FINDINGS</b>
	Amend Section 101.1 - Title.	A
	Amend 103.1 General	A
	<b>Amend 903.2.8 - Group R</b>	C
	<b>Amend 903.2.11 - Specific building areas and hazards.</b>	C
	<b>Add 903.2.11.7 - Occupancies in fire hazard severity zones and within the Malibu-Santa Monica Mountains or San Gabriel South-face Areas.</b>	C

**EXPRESS FINDINGS**

- A. **Local Administrative Finding** – This amendment is necessary for administrative clarification. It does not modify a Building Standard pursuant to Sections 17958 and 18941.5 of the California Health and Safety Code and does not require an express finding to be made pursuant to Sections 17958.5 and 17958.7 of the California Health and Safety Code. This amendment established administrative standards for the effective enforcement of building standards and therefore needs to be incorporated into the code to assure that new buildings and structures and additions or alterations to existing buildings or structures are designed and constructed in accordance with the scope and objectives of the Codes.
  
- B. **Local Geological Conditions** – The City of Agoura Hills is located in an area with high seismic risk with buildings and structures constructed over and near a vast array of fault systems capable of producing major earthquakes, including but not limited to the recent 1994 Northridge Earthquake, the 1987 Whittier Narrows Earthquake, the 1971 San Fernando Earthquake and the 1933 Long Beach Earthquake. Earthquakes from these faults could produce primary effects such as strong ground shaking or ground rupture, and secondary effects such as liquefaction and landslides. These primary and secondary effects pose a significant hazard to the City’s building stock and infrastructure, and to public health and safety. This could result in the collapse of vulnerable buildings and bridges, ground rupture affecting roads and highways, and liquefaction damaging buildings and pipelines (water, gas, and sewage). Fire from broken gas lines and the lack of water from broken water lines could result in major damage. Landslides caused by strong shaking, possibly in combination with wet weather conditions, could block highways and railroads, thereby isolating parts of the City and affecting emergency response. Earthquake-induced landslides could also produce rocks to fall and possibly strike and damage buildings and vehicles. Furthermore, the soils in some areas of the City are expansive and unstable. The protection of human life and the preservation of property support the imposition of fire protection, grading, and structural requirements greater than those set forth in codes adopted by the California Building Standard Commission. The proposed modification will reduce the failures and injuries, save lives,

and minimize structural damages, and therefore needs to be incorporated into the code to assure that new buildings and structures and additions or alterations to existing buildings or structures are designed and constructed in accordance with the scope and objectives of the Codes.

- C. **Local Climatic Condition** – The seasonal hot and dry weather in combination with Santa Ana winds frequently create a high potential for wildland fires in areas of the City of Agoura Hills which is located in a very high fire hazard severity zone. These conditions create an environment where the entirety of local fire department personnel, as well as resources from outside the community, are required to control, monitor, fight and protect against such fire situations in an effort to protect life and preserve property. In addition, the region is within a climate system capable of producing major winds, fire, and rain-related disasters, including but not limited to those caused by the Santa Ana winds and El Nino (or La Nina) subtropical-like weather in areas of the City without adequate fire department personnel to protect against and control such a situation. These unique problems caused by the climactic conditions in the City can be relieved and controlled to an extent by advanced construction techniques and requirements in the City. This region is especially susceptible to more active termite and wood-attacking insects and micro-organisms. To better protect the community, more restrictive requirements are imposed than those set forth in codes adopted by California Building Standard Commission.
- D. **Local Topographical Conditions** – The City of Agoura Hills is located within a very high fire hazard severity zone with many hillsides. Due to varied topography, access to structures increases response time and delays fire suppression efforts. An extended response time will allow fires to grow beyond the control of initial attack fire suppression resources. Large structure fires in hillside areas will have a greater likelihood of starting a wildfire, which may expose additional structures to the fire. Furthermore, the topography of the City is characterized by steep slopes and unstable soils, if failed, can impede and delay rescue efforts. The above-described local topographical factors and problems support the imposition of requirements greater than those set forth in codes adopted by the California Building Standard Commission.
- E. **Local Topographical and Geological Conditions** – The City of Agoura Hills is located in a hilly area having buildings and structures constructed over and near a vast array of fault systems capable of producing major earthquakes, including but not limited to the recent 1994 Northridge Earthquake. Additionally, the topography within the City includes significant hillsides with narrow and winding access that makes timely response challenging and difficult. The hilly terrain with potential hazards such as slides, erosion, and local floods can be mitigated with the proposed amendments. To better protect the community, more restrictive requirements are imposed than those set forth in codes adopted by California Building Standard Commission.
- F. **Local Climatic and Geological Conditions** – The City of Agoura Hills is located in a hilly area having buildings and structures constructed over and near a vast array of fault systems capable of producing major earthquakes, including but not limited to the recent 1994 Northridge Earthquake. The region is further impacted by the construction of buildings and structures utilizing traditional construction materials that impact the amount of energy, air quality, greenhouse gas emission, and construction waste in the area. The proposed amendment addresses structural designs specific to intermodal shipping containers, reduces the environmental impact of unused and unrecycled intermodal shipping containers, and increases sustainability by reducing the consumption of traditional construction materials. The proposed modification needs to be incorporated into the code to assure that new buildings and additions to existing buildings utilizing intermodal shipping containers are designed and constructed in accordance with the scope and objectives of the California Building Code and California Green Building Standards Code.